



CURVV EV

OWNER'S MANUAL



TATA MOTORS

REV 00 /DEC 2024

CUSTOMER ASSISTANCE

In our constant endeavour to provide assistance and complete service backup, TATA MOTORS has established an all India customer assistance centre.

In case you have a query regarding any aspect of your vehicle, our Customer Assistance Centre will be glad to assist you on our Toll Free no. **1800 209 8282**

You can also approach nearest TATA MOTORS EV dealer.

TATA MOTORS 24X7 Roadside Assistance Program offers technical help in the event of a breakdown. Call the toll-free Road-side Assistance.

For additional information, refer to "24X7 Roadside Assistance" section in the Owner's manual.

For updated Owner's Manual and Infotainment Manual refer below link

<https://ev.tatamotors.com/support.html>

For Dealer Network refer below link

<https://ev.tatamotors.com/dealer-locator.html>



Dear Customer,

Welcome to the TATA MOTORS family,

Thank you on the purchase of TATA MOTORS vehicle.

As a global Indian automobile manufacturer, we focus on innovation, technology and build high quality products with exceeding values of “Connecting Aspirations”.

The Owner’s Manual will familiarize you with the operations, equipment description, features that are either as standard or optional on your vehicle. It is requested you read this manual carefully and follow the instructions and recommendations as mentioned.

You are advised to carry out service, maintenance and repairs at TATA MOTORS EV Dealers and EV Authorized service centers through out the life of your vehicle. Always use genuine parts for continued performance of your vehicle. Avoid modification, non-genuine accessories fitment on your vehicle. TATA MOTORS does not carry any liability arising due to it. Always keep this manual in the vehicle.

You can contact our dealer or Customer Assistance toll free no. (1800 209 8282) in case of any query or support required.

Information provided in this Owner’s Manual is explicit at the time of publication. However, as TATA MOTORS continues to make changes and improve products, it reserves the right to make changes in this manual or any product at any time, without notice and without any obligations.

We look forward for your continued association with us for many years to come.

Wishing you a Safe and pleasant driving experience.

TATA PASSENGER ELECTRIC MOBILITY LTD.

Floor 3, 4, Plot-18, Nanavati Mahalaya, Mudhana Shetty Marg, BSE, Fort,

Mumbai, (MH) - 400 001, India

01. INTRODUCTION TO EV			
EV Overview	1	Important Tips	45
Know Your Vehicle	5	Types of Charging	47
Important Messages	9	V2X Charging	60
Important Information	9	05. OPENING AND CLOSING	
02. SAFETY		Keys	69
General Safety Tips	11	Doors	73
Seats	12	Windows	77
Seat Belts	14	Bonnet and Charging Flap	79
Supplementary Restraint System (SRS - Airbags)	18	Mechanically Operated Tailgate	82
Children on Board	26	Power Operated Tailgate	83
Additional Safety Features	34	06. INSTRUMENT CLUSTER	
Anti-theft Device-immobilizer/ PEPS	37	Digital Display (7" Inch)	89
03. BATTERY AND COMPONENT		Driver Information System (DIS)	93
High Voltage Battery System	39	Digital Display (10.25" Inch)	114
Tips To Conserve Battery Life	42	Driver Information System (DIS)	119
04. CHARGING		Warnings and Indicators	136
Instructions To Follow	43	Display Messages On Instrument Cluster (if equipped)	145
		Audio Reminders	148

CONTENTS

07. STARTING AND DRIVING

Before You Start Your EV	153
Electric Power Assisted Steering (EPAS)	154
Steering Lock / Unlock And Ignition Switch	156
Driving Tips	159
Tips To Get Maximum Range While Driving EV	162
Drive and Shifter Modes	167
Operating of Lights and Wipers	170
Seats Adjustments	173
Mirrors	180
Driving Support System	183
Automatic Vehicle Hold (if equipped)	202
Advanced Driver Assistance Systems (ADAS) (if equipped)	204
Acoustic Vehicle Alerting System (AVAS) (if equipped)	238

08. INTERIOR AND EXTERIOR FEATURES

Climate Control	239
Fully Automatic Temperature Control (FATC)	241

FATC Sensors	245
Cabin Air Purification	246
Fascia Switches	247
Power Sunroof (if equipped)	248
Steering Mounted Controls (if equipped)	252
Infotainment System Display	255
MIC (if equipped)	255
Speakers & Tweeter (if equipped)	256
USB Port (if equipped)	256
Power Socket	257
Lamps	257
Roof Grab Handle	258
Mood Lights/ambient Lights (if equipped)	259
Vehicle Telematics (if equipped)	259
Wireless Power Charging (if equipped)	260
Shark Fin Antenna	266
Welcome and Good Bye Strategy	267

09. STOWAGE AREA

Storage Compartment	269
Glove Box	270
Driver Side Coin Box	271
Utility Pockets on Front Doors	271
Utility Pockets on Rear Doors	271
Center Console	272
Foldable Arm Rest (if equipped)	272
Luggage Compartment	273
Hooks (if equipped)	274
Luggage Compartment Cover	275
Frunk (if equipped)	275

10. EMERGENCY AND BREAKDOWN

Emergency Equipment	277
Spare Wheel Removal Procedure	278
In Case of Flat Tyre	279
Towing	283
Fuses	285
Bulb Specification	302

24 X 7 Roadside Assistance	303
----------------------------	-----

11. TECHNICAL SPECIFICATIONS

Lubricant Specifications	315
Vehicle Specifications	316
Vehicle Dimensions	319
Aggregate Identification	320

12. MAINTENANCE AND CARE

Service Instructions	321
Service Schedule	322
Motor Compartment	329
Brake Fluid Level	330
Windshield Washer Fluid Level	330
12V Battery	331
Tyres	332
Vehicle Parking for Long Duration (non - Use Maintenance)	335
Smart Key Battery Replacement (For PEPS variant)	336

CONTENTS

On Board Diagnostic (OBD II) System	337
Do it Yourself	338
Car Care	343
Value Added Services	346
Vehicle Exterior Enrichment	345
Vehicle Interior Enrichment	346

13. WARRANTY

Vehicle Warranty - Terms and Conditions	347
---	-----

14. EXTENDED WARRANTY

Extended Warranty - Terms and Conditions	349
--	-----

EV OVERVIEW

An electric vehicle is powered by a battery - E-drive and it does not need any type of fossil fuel. While conventional vehicles use an internal combustion engine and gasoline or diesel as fuel, electric vehicles use electrical energy that is stored inside the high voltage battery. As a result, electric vehicles run on electricity, they are eco-friendly - they do not require fuel and are zero emission vehicles.

Review and Characteristics

This is an electric vehicle. Some of the vehicle's systems operate differently and have different operating characteristics than vehicles equipped with an internal combustion engine. It is important to carefully read the entire Owner's Manual for this reason.

This vehicle uses two types of battery systems, high voltage battery system, it powers the inverter and electric motor to propel the wheel. The low voltage battery system (12V) provides power to the vehicle systems and features such as the audio system, supplementary restraint systems, headlights and windshield wipers.

The high voltage battery also charges the 12-volt battery.

The high voltage battery must be charged with electricity before the vehicle can be driven. As the vehicle operates, the battery gradually discharges and the vehicle needs to be plugged in for charging. To increase the range of the EV, regenerative braking has been incorporated basically, while the vehicle is coasting or braking, the motor works as a generator and converts the vehicle motion (kinetic energy) to electrical energy to charge the HV battery.

This vehicle is considered to be an environmentally friendly vehicle because it does not emit exhaust gases, and thus is cleaner than the conventional vehicles in terms of air pollution.

Main Components**On-Board Charger (OBC)**

A device that charges the high voltage battery by converting AC power from a domestic supply into DC power and supplying it to the battery.

Inverter

A device that transforms direct current (DC) from the high voltage battery into alternating current (AC) to power the electric motor. It also converts braking energy into electrical energy and charges the high voltage battery while decelerating or braking.

DC-DC Converter

A device that converts HV DC power from the HV battery to LV DC power which is required to maintain LV battery charge, which in turn powers the LV systems like lights, wipers, infotainment, etc. in the vehicle.

Electric Motor

A device that converts electrical energy into rotational mechanical energy which is then transferred as rotational torque to the wheels through the gearbox in order to drive the vehicle.

INTRODUCTION TO EV

High Voltage Battery (Lithium-ion)

An on board high voltage electrical energy storage device

Power Distribution Unit

Distributes power from the high voltage battery to the HV components like inverter, DC-DC converter, E-compressor etc.

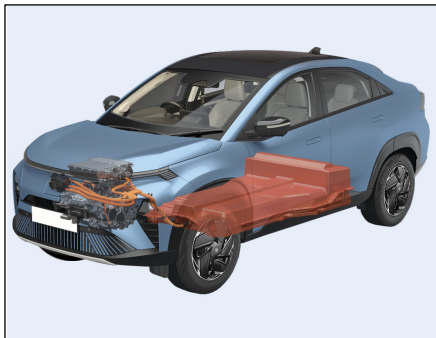

General Warnings

- Your vehicle contains a sealed Li-ion high voltage battery. If the Li-ion battery is disposed of improperly, there is a risk of severe burns and electrical shock that may result in serious injury or death and there is also a risk of environmental damage.
- The EV system uses high voltage DC current. The system can be hot during and after starting and when the vehicle is shut off. Be careful of both the high voltage and the high temperature.
- Avoid being exposed to high voltage components in the first place. Observe all high voltage warning labels as these indicate high voltage components or areas. Observe all orange cables, large and small as these carry high voltages.
- Do not touch high voltage components while the vehicle is in operation or ON state.
- Do not disassemble, remove or replace high voltage parts and cables as well as their connectors because they can cause severe burns or electric shock that may result in serious injury or death.
- The vehicle high voltage system has no user serviceable parts. It is recommended that you take your vehicle to TATA MOTORS EV Authorised Service Centre.
- When leaving the vehicle, be sure to turn off the EV system. The EV system uses high voltage current. Failure to follow the proper handling instructions may cause serious injury or death.

Safety of the High Voltage System

- Do not perform any modifications or work on the vehicle, especially maintenance and repair work on the high voltage system. Avoid retrofitting and accessories.
- If work is not carried out properly, there is the risk of fire and fatal injury from electrocution due to the high voltage system.
- TATA MOTORS recommends to have modifications and work on the vehicle only to be carried out by TATA MOTORS EV Authorised Service Centre.
- Your vehicle's high voltage system is a self-contained system. Safety is ensured as long as no unauthorized work is performed on high voltage electrical components or on the chassis.

High Voltage System: Contact with Water

The high-voltage system is typically safe even in the following example situations:

- Water in the foot well, for instance after a rainstorm when sunroof was kept open.
- Liquid escapes in the trunk.
- In these cases there is no risk of injury from electrocution. Other damage to the vehicle is possible.

INTRODUCTION TO EV

Common Terminologies and Abbreviations

EV – Electric Vehicle

HV battery – High Voltage battery

LV battery – Low Voltage (12V) battery

AC – Alternating Current

DC – Direct Current

OBC – On Board Charger

PDU – Power Distribution Unit

VCU – Vehicle Control Unit

BMS - Battery Management System

OBD - On Board Diagnostics

SoC – State of Charge

SRS – Supplementary Restraint System

CRS - Child Restraint System

DAB – Driver Airbag

PAB – Passenger Airbag

ABS - Anti-lock Braking System

EBD - Electronic Brake Force Distribution

ESC - Electronic Stability Control

PEPS - Passive Entry/Passive Start

BCM - Body Control Module

POT - Power Operated Tailgate

UID - User Identification Device

ESCL – Electronic Steering Column Lock

EPAS – Electric Power Assisted Steering

LED – Light Emitting Diode

DRL – Daytime Running Lamp

ORVM - Outer Rear View Mirror

IRVM – Inside Rear View Mirror

EC-IRVM – Electric Chromic Inside Rear View Mirror

HVAC – Heating Ventilation and Air Conditioning

FATC – Fully Automatic Temperature Control

DIS – Driver Information System

DTE - Distance to Empty

IGN – Ignition

ACC – Accessory

EPB – Electronic Parking Brake (EPB)

CPL – Centre Position Lamp

V2L – Vehicle to Load

V2V – Vehicle to Vehicle

ADAS - Advanced Driver Assistance Systems

AVAS - Acoustic Vehicle Alerting System

iVBAC - Introducing the Intelligent Vacuum-less Boost & Active Control

KNOW YOUR VEHICLE

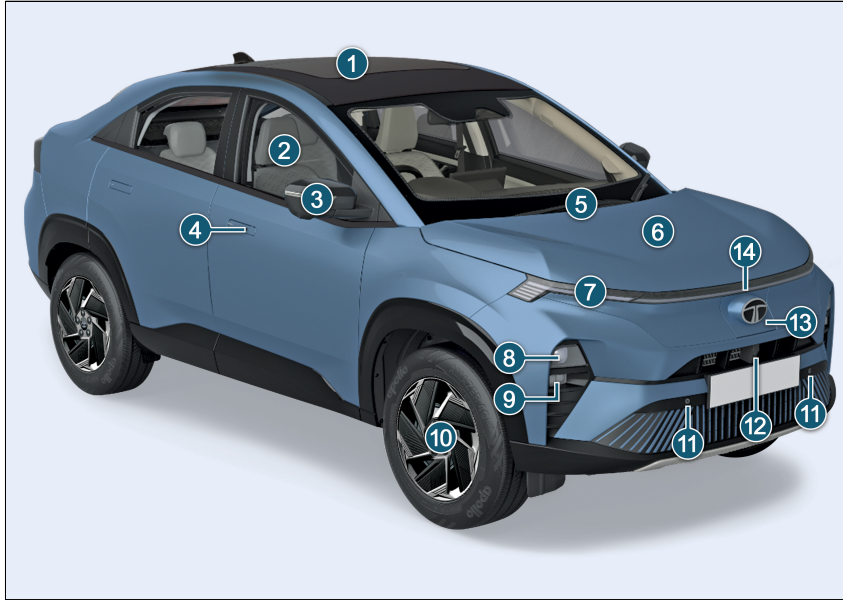

1. Sunroof
2. Windows
3. Rear View Mirror with Camera
4. Door Handle Switch (DHS)
5. Front Windshield Wipers
6. Bonnet
7. Turn Indicator/ DRL/ Position Lamp
8. Head Lamp
9. Fog Lamp with cornering
10. Alloy Wheels
11. Front Parking Sensors
12. Front Camera
13. Charging Flap
14. Center Position Lamp

* Image for your reference, actual vehicle may differ.

* Features listed above may or may not be applicable to your vehicle

INTRODUCTION TO EV

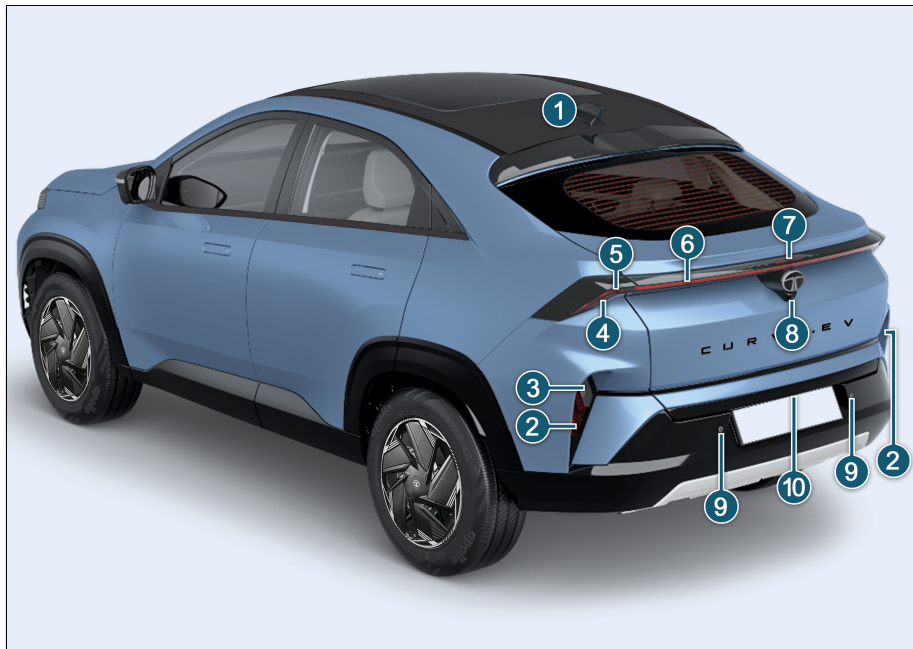

1. Shark Fin Antenna
2. Reflex Reflector
3. Reverse Lamp
4. Stop Lamp
5. Turn Indicator / Position Lamp
6. Position Lamp /
Partial Turn Indicator
7. High Mounted Stop Lamp
8. Rear Camera
9. Rear Parking Sensors
10. Tail Gate Open Switch

* Image for your reference, actual vehicle may differ.

* Features listed above may or may not be applicable to your vehicle.



1. Steering Mounted Switches
2. Regeneration Lever
3. Seat Ventilation
4. Power Seat Adjustments
5. Driver side Coin Box
6. Bonnet Opening Lever
7. ORVM adjusting Knob
8. Door Opening Lever
9. Door Locking/Unlocking Knob
10. Driver side Power Window Express Up / Down
11. Power Window Switches
12. Inhibit Switch

* Image for your reference, actual vehicle may differ.

* Features listed above may or may not be applicable to your vehicle.

INTRODUCTION TO EV

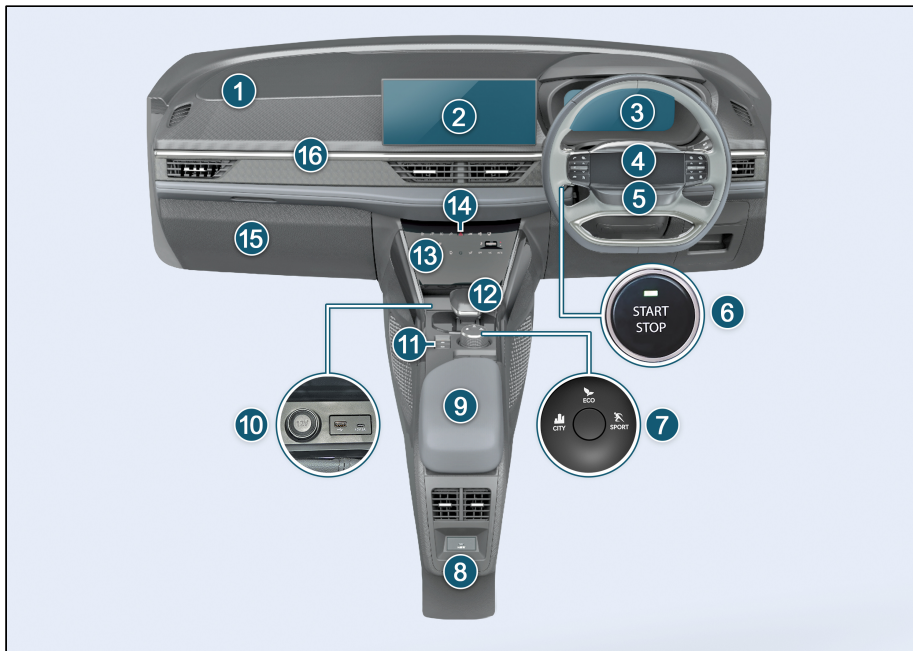

1. Passenger Airbag
2. Infotainment Display
3. Instrument Cluster
4. Horn pad
5. Driver Airbag
6. Start/Stop Switch
7. Drive Modes
8. USB Charger for Rear Passenger
9. Arm Rest
10. Power Socket & USB
11. Auto Hold and EPB
12. Mono shifter
13. Temperature Control Panel
14. Hazard Warning Switch
15. Glove Box
16. Multi color Mood light

* Image for your reference, actual vehicle may differ.

* Features listed above may or may not be applicable to your vehicle.

IMPORTANT MESSAGES

In this Owner's Manual, you will find the text under the heading "WARNING", "CAUTION" and "NOTE" which highlights important information. Pay particular attention to these highlighted messages. The Images / Illustrations in this owner's manual are only for reference. It may differ with actual vehicle.

NOTE

Indicates additional information that will assist you in gaining the optimum benefit and care for your vehicle.

WARNING

Indicates procedures or information that must be followed precisely in order to avoid the possibility of severe personal injury and serious damage to the vehicle.

CAUTION

It indicates to be careful. You are capable of doing something that might result in damage to equipment.

IMPORTANT INFORMATION

Vehicle in water logged condition



- Before driving through water logged areas ensure that water is below running board.
- Unseen pot holes could damage under surface of the vehicle.
- Drive slowly and maintain constant acceleration.
- After passing the water logged area ensure to press brakes intermittently to dry the brake disc.

WARNING

- Do not drive through heavy water logged area.
- Water may enter into vehicle interior and motor compartment which may damage electrical, electronic circuits.

Vehicle in flood



WARNING

- If your vehicle gets flooded and if you see gas bubbles around submerged EV, smoking, it may indicate a damaged battery, Immediately contact TATAMOTORS EV Authorized Service centre.
- If your vehicle is flooded wait for water level to recede.
- Once the water is receded, approach the vehicle, open all doors and let the water inside the vehicle get drained completely.
- Start the ignition and check if all electronic are working. Take your vehicle to nearest TATA MOTORS EV Authorized Service centre get it inspected.
- Remove floor carpet and open the rubber/plastic gourmet provided on floor board, stepney space for water to recede from interior flooring of the vehicle completely.

INTRODUCTION TO EV

Vehicle In fire

In case of vehicle fire, immediately evacuate vehicle and contact local fire tender responder. They possess proper training and equipment to safely extinguish vehicle fire. Inform them your vehicle is EV. Contact nearest TATA MOTORS EV Authorised Service Centre for further assistance.



WARNING

- If there is damage to EV, there is risk of thermal runaway which could lead to fire
- If the damage occurs in saltwater, the risk of battery short circuits leading to fire is increased.
- Do not modify your vehicle.
- Do not install high-wattage bulbs, non-genuine lamps, horns
- Do not modify suspension, wheels, tyres.

- Stick to manufacturer-recommended parts.
- Avoid tampering with the wiring harness it can lead to short circuits.

CAUTION

Do not store or carry inflammable materials in the vehicle.

Vehicle Scrapping

Your vehicle is equipped with SRS Air Bags and Seat Belt Pretensioner, ensure to remove and disposed it by qualified service centre or by TATA MOTORS Authorised Service Centre before scrapping your vehicle.

Vehicle Cyber Attack

Modern vehicles are equipped with internet connectivity for navigation, entertainment and diagnostics, making them vulnerable to cyber attacks.

Vehicles collect and stores personal data, which can be targeted by hackers.

Cyber attacks can compromise infotainment system, brakes, steering and engine control, leading to severe cyber risk.

Vehicle Cyber Security



- Refrain from connecting the vehicle to public or unsecured Wi-Fi networks.
- Ensure your vehicle is physically secured by locking doors and parking in safe areas to prevent from unauthorized access.
- Never leave your keys in the car, even if you are nearby.
- Keep your vehicle updated with latest software versions.
- Pay attention to any security alerts or notifications and follow the guidelines.
- Disable the blue tooth of the car where not required and vehicle is not in use.
- Keep infotainment app's login credentials private & do not share it with anyone.

GENERAL SAFETY TIPS

- Safety consciousness not only ensures your safety and the safety of other road users, but it also helps to reduce the wear and tear on your vehicle.
- How quickly you make decisions to avoid an accident.
- Your ability to concentrate.
- How well you can see and judge objects.
- How well familiar you are with your vehicle controls and its capabilities.
- Turn 'ON' the side indicators at least 30 meters before taking a turn or changing the lane.
- Decelerate to a safe speed before taking turn. Do not apply brakes during cornering.
- When overtaking other vehicles, watch out for the oncoming vehicle.
- Never drive under the influence of alcohol or drugs.
- If your vehicle is equipped with infotainment/ navigation system, set and make changes to your travel route only when the vehicle is parked.
- Program radio presets with the vehicle parked, and use your programmed presets to make radio use quicker and simpler.
- If your car gets flooded and has soaked carpeting or water on the flooring, you should not try to start the engine, we recommend to kindly contact TATA MOTORS Authorised Service Center.

NOTE

Do not remove the labels attached at different places on your vehicle, they include safety instructions or vehicle specifications.

SAFETY

SEATS

Your vehicle is provided with good seating comfort. To make your journey more safe and enjoyable we recommend you to follow below warnings and cautions.

Driver's seat

WARNING

- Do not adjust seat while driving / vehicle is moving. Doing so could result in loss of control, and an accident causing death, serious injury, or property damage.
- Always sit as far back as possible from the steering wheel while maintaining comfortable control of the vehicle. Fitment of seat covers on driver seat with airbags is strictly prohibited.
- Do not keep any sitting cushion on seats. This may result in serious or fatal injury in the event of accident.

WARNING

- After adjusting the seat make sure it is securely locked by pushing it forward and backwards without using lock release lever. Sudden or unexpected movement of the driver's seat could cause to lose control of the vehicle resulting in an accident.
- All passengers must be seated in seats and restrained with seat belt properly while riding in vehicle
- If there are occupants in the rear seats, be careful while adjusting the front seat position.

Front Passenger Seat

WARNING

Never ride in a vehicle with a front seat-back fully reclined. This may lead to serious injuries. Fitment of seat covers on front passenger seat with airbags is strictly prohibited.

Rear Seat Back

WARNING

The rear seatback must be securely latched. If not, passengers and objects could be thrown forward resulting in serious injury in the event of a sudden stop or collision. Luggage and other objects in boot should be kept flat. If large, heavy, or piled they must be secured properly. No passenger should ride in the boot area or sit or lie on folded seatbacks while the vehicle is in motion.

Applicable for Hatchback/SUV

WARNING

Under no circumstances should objects be piled higher than the seatbacks. Failure to follow these warnings could result in serious injury in the event of a sudden stop or collision. Ensure that objects are securely fastened.

⚠ WARNING

Storing items against seatback or in any other way interfering with proper locking of a seatback could result in serious or fatal injury in a sudden stop or collision. After resetting the seatback to its seating position, make sure it is securely latched by pushing it forward and backwards.

⚠ CAUTION

Your hands might be cut or injured by the sharp edges of the seats mechanism during looking for small objects trapped under the seats or between the seat and the center console.

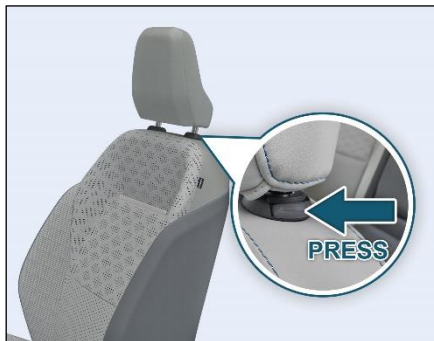
**Head Restraint
Front Seat**

Adjust the head restraint so that it is as close to the head as possible and the center of the head restraint supports the back of the head at eye level.

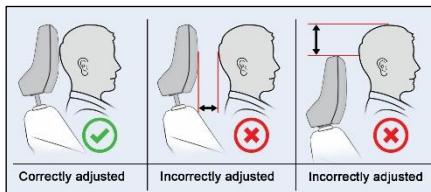
**⚠ WARNING**

Do not drive the vehicle without the seat head restraints. Head restraints are intended to help reduce injuries during an accident.

Rear Seat

Adjust the head restraint so that it is as close to the head as possible and the center of the head restraint supports the back of the head at eye level.



SAFETY

SEAT BELTS

This section describes your Vehicle's Seat belts, Airbags and Child restraints system. Please read and follow all these instructions carefully to minimize risk of severe injury or death.

- Seat belts are the primary restraints system in the vehicle. All occupants, including the driver, should always wear seat belts. Your vehicle is equipped with three point seat belts for all occupants.
- Sit back and adjust the driver seat. Make sure that your seat is adjusted to a good driving position and the back of the seat is upright.

Buckling the Seat Belt

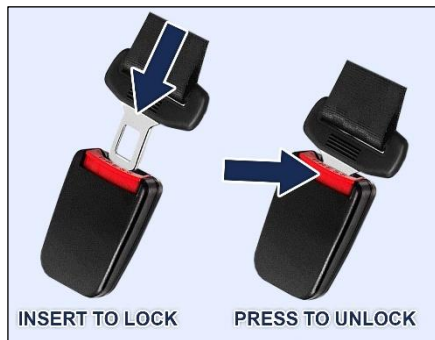

- Grasp the tongue then slowly pull out the seat belt over the shoulder and across the chest. When the seat belt is long enough to fit, insert the tongue into the lock buckle until you hear a “CLICK” which indicates that the seat-belt is securely locked. (Refer “INSERT TO LOCK” image)
- Position the lap portion of seat belt across your pelvic bone, below your abdomen. To remove slack, pull up a bit on the shoulder seat belt. To loosen the lap portion seat belt if it is

too tight, tilt the tongue and pull on the lap seat belt. A snug seat belt reduces the risk of sliding under the seat belt in a collision. Ensure that the seat belt running over the body (shoulder segment and lap segment) does not have any twist. Twisted seat belt may not offer effective protection when required.

- Ensure that the seat belt webbing is straight and not twisted. Twisted seat belts may not work properly in case of collision.

NOTE

It is not advised by TATA Motors to remove the mini tongue from small buckle, located at rear middle seat.

Releasing the Seat Belt

To release the seat belt, push the red button on the lock buckle (refer "PRESS TO UNLOCK" image). Ensure to hold seat belt during unlocking and release it slowly towards the seat belt mounting. The seat belt will automatically retract to its stowed position. If necessary, slide the tongue down the webbing to allow the seat belt to retract fully.

WARNING

Due to retractor reversal action if you leave the seat belt from the unlock position it may hit you or parts like glass in the way which may cause injury to you or damage to the vehicle.

WARNING

- Each seating position and seat belt assembly must be used by one occupant.
- Be careful not to damage or tamper the seat belt webbing or hardware.

Inspect the seat belt system periodically, checking for cuts, frays, or loose parts. A frayed or torn seatbelt could rip apart in a collision and leave you with no protection.

- If the seat belt webbing or hardware is damaged, get it replaced at TATA MOTORS EV Authorised service centre.
- Do not insert any items such as coins, clips, etc. into the seat belt buckles, and be careful not to spill liquids into these parts. If foreign materials get into a seat belt buckle, the seat belt will not work properly.
- Do not wear seat belts over hard, sharp or fragile items in clothing, such as pens, keys, spectacles etc.
- Do not use any accessories on seat belts or modify in any way the seat-belt system. Devices claiming to improve occupant comfort or repositioning the seat belt, can reduce the protection provided by the seat belt and increase the chance of serious injury in a collision.

Seat Belt Height Adjustments (if equipped)

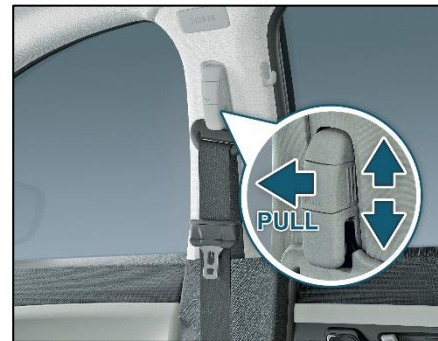

If height adjustment is provided in the seat belt, occupant can adjust it as per their comfort.

SAFETY

Use of Seat Belts for Pregnant Women

WARNING

- Pregnant women must wear a correctly positioned seat belt. It is safer for mother as well as unborn child.
- Pregnant women should wear the lap part of the seat belt across the pelvic bone (hips) as snug across the pelvic bone (hips) as possible. Keep the seat belt low so that it does not come across the abdomen. That way the strong bones of the hips will take the force if there is a collision.



Seat Belt Warning Lamp



Your vehicle is equipped with Seat Belt Reminder (SBR) for all occupants

NOTE

- *Whenever an occupant is not sitting in any seating position then seat belt reminder beeping sound will not be played in instrument cluster.*
- *If any material is kept on any seat then SBR beeping sound may be played in instrument cluster. Please do not keep any material on seat.*
- If the driver or any passenger do not fasten the seat belt, seat belt reminder lamp will blink and a buzzer will sound for pre-defined duration until the seat-belt is buckled.

- If any passenger seat is occupied by child (without child seat), system may detect occupancy and warn with seat belt warning. It is not taken to mean child can occupy any passenger seat and use seat belt. Please refer CRS section for recommended seating position if child is sitting with child seat.

NOTE

Fitment of seat covers on any seating position is strictly prohibited. It may affect the function of occupant sensor.

Seat Belts With Pre – Tensioner (if equipped)

You can use the pre-tensioner seat belts in the same manner as ordinary seat belts. The seat belt pre-tensioner system works in conjunction with the Supplementary Restraints System (SRS-Airbags). In the event of a collision, as may be necessary, pre-tensioner tightens the seat belt so that it fits the occupant's body more snugly. When pre-tensioner activates, there could be some noise and release of smoke. This is normal and there are no health hazards or fire risk.

Seat Belt with Load Limiter (If equipped)

You can use the load limiter in the same manner as ordinary seat belts. The seat belt load limiter system works in conjunction with the Supplementary Restraints System (SRS-Airbags). In the event of a collision, as may be necessary, load limiter reduces the load on the rib cage region of the occupant.

If the vehicle has been involved in a collision, get it inspected immediately at TATA MOTORS EV Authorised Service Centre.

SAFETY

SUPPLEMENTARY RESTRAINT SYSTEM (SRS - AIRBAGS)

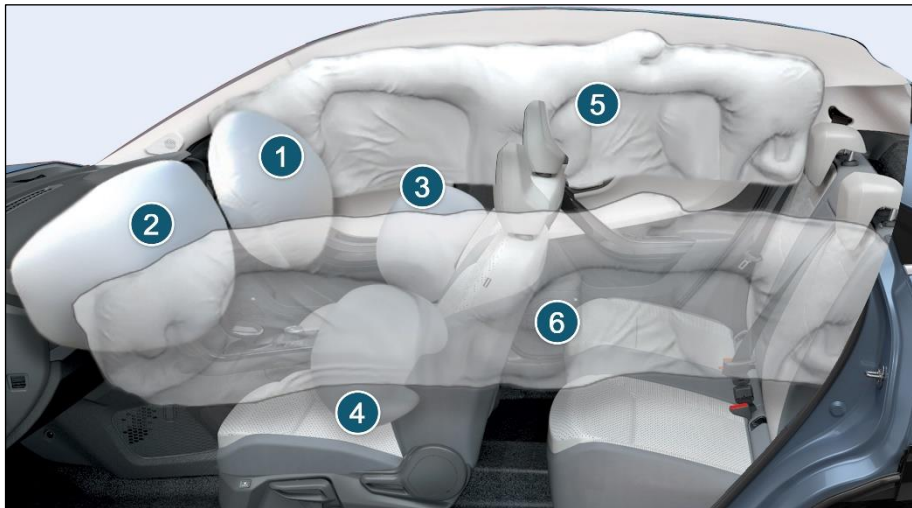

The SRS [Supplementary Restraint system] is designed to provide protection to occupants in case of collision or sudden impact, when crash is detected, the SRS airbag system deploys airbags to help reduce the risk of injury to the occupant. It works in conjunction with seat belts.

There are 6 airbags provided in your car:

1. Driver Airbag
2. Front Passenger Airbag
3. Side Airbag RH
4. Side Airbag LH
5. Curtain Airbag RH
6. Curtain Airbag LH

The driver airbag is mounted in the centre of the steering wheel. The front passenger airbag is located inside the dashboard in front of the passenger seat. The airbags have suitable indications on steering wheel and on dash board.

Side airbags are mounted in front row seats.

Curtain airbags are mounted above the doors along the roof on both sides.

The word 'AIRBAG' is marked at adjacent locations of respective airbags.

The 'SRS' system also comprises of the following components depending upon the provided safety features in vehicle.

- Seat belt Pre-tensioners
- Seat belt with load limiters
- Airbag 'SRS' ECU (Electronic Control Unit)
- Collision Sensors
- SRS wiring harness
- SRS Warning lamp

The System is active when ignition switch is in the "ON" position or the ignition mode is "ON". Airbags are designed to inflate in collisions when required.

In the event of a collision, the collision sensors will detect signals, and if the Airbag ECU judges that the signals represent a severe collision, will trigger the airbags. The inflated Airbags provide a cushion to the occupants. The Airbag inflates and deflates so quickly that you may not even realize that it has activated. The Airbag will neither hinder your view

nor make it hurdle to exit the vehicle. Airbag inflation is virtually instantaneous and occurs with considerable force, accompanied by loud noise and smoke, which is normal. The inflated airbag, together with seat belts, limit the movement of an occupant, thereby reducing the risk of injury.

When an airbag inflates, you may see some smoke like particles. The particles are a normal by product of the process that generates the non-toxic gas used for airbag inflation. These airborne particles may irritate the skin, eyes, nose, or throat. If you have skin or eye irritation, rinse the area with water. For nose or throat irritation, move to fresh air. Also sometimes the smoke can cause breathing problems, in such cases get fresh air promptly.

It is not advisable to drive your vehicle after the airbags have been deployed. If you are involved in another collision, the airbags will not be in place to protect you.

NOTE

- *Open your windows and doors as soon as possible after collision to reduce prolonged exposure to the smoke and powder released by the inflating Airbag.*
- *Do not touch the Airbag container's internal components immediately after an Airbag has inflated. The parts that come into contact with an inflating Airbag may be very hot.*
- *Always wash exposed skin areas thoroughly with lukewarm water and mild soap.*

WARNING

- Even in vehicle with airbags, all the occupants must always wear the seat belts provided. In order to minimize the risk and severity of injury in the event of a collision.
- If an occupant is out of position during collision, the rapidly deploying Airbag may forcefully contact the occupant causing serious or fatal injuries.

SAFETY

WARNING

- Always use seat belts and CRS at all times. Even with airbags, you can be seriously injured or killed in a collision if you are not wearing seat belt properly or not wearing seat belt when airbag inflates.
- All occupants should never sit or lean unnecessarily close to the Airbags.
- Move your seat as far back as possible from front Airbags, while still maintaining control of the vehicle.
- All occupants should sit upright with the seat back in an upright position, centered on the seat cushion with their seat belt on, legs comfortably extended and their feet on the floor until the vehicle is parked and the IGN is turned OFF.
- Do not allow the all occupants to place their feet or legs on the dashboard.

Passenger Airbag (PAB) Switch

Passenger airbag switch is used to activate and de-activate the passenger airbag in the vehicle.

The switch is located on the left side of the dashboard and can be accessed once the co-driver side door is opened.



PAB Switch ON

When an adult is seated in the front passenger seat, ensure that PAB switch is turned to 'ON' position. This will ensure that the passenger airbag is operational in the event of a collision.

PAB Switch OFF

If rearward facing child seat needs to be installed on front passenger seat to carry the child then ensure PAB switch is turned OFF. This will ensure that the passenger airbag will remain de-activated in the event of a collision.

This switch can be operated by using mechanical key only. For more details refer "Keys" section in this Manual.

Passenger Airbag (PAB) Indicator

Passenger airbag indicator is provided to notify an occupant, whether passenger airbag is activated (ON) or deactivated (OFF) in vehicle.

PAB indicator is located on roof near roof lamp.



PAB Indicator ON:

When the PAB switch is turned to 'ON' position to activate the airbag, 'ON symbol & text' will illuminate in amber color.



PAB Indicator OFF:

When the PAB switch is turned to 'OFF' position to deactivate the airbag, 'OFF symbol & text' will illuminate in amber color.



Wrong Seating Positions



SAFETY



i NOTE

- Never place your arm over the air-bag as a deploying airbag can result in serious arm fractures or other injuries.
- Do not allow the passengers to lean their heads or bodies onto doors or place objects between the doors and passengers when they are seated on seats equipped with side and/or curtain Airbags.

- Do not place or stick any items in the vehicle, except at designated locations (such as utility bins, cup/bottle holders, boot space etc). Loose items may act as a projectile during a collision and cause severe to fatal injuries.
- Please be aware that any unsecured item in your vehicle, such as your pet, unsecured CRS or a laptop, can become a potential hazard in the event of a collision or sudden stop, causing injuries to occupants in the vehicle.
- Coat hooks (if equipped) must be used only for that purpose. Never hang other items on to those hooks. This could affect deployment of the Airbags, and may lead to severe to fatal injuries.
- Always contact your TATA MOTORS EV Authorised Service Centre if the vehicle is damaged, even if airbag has not inflated or if any part of an airbag module cover shows sign of cracking or damage.

 **WARNING**

If your SRS malfunctions, the Airbag may not inflate properly during a collision thereby increasing risk of serious injury or death. If any of the following conditions occur, your SRS is malfunctioning:

- The SRS warning lamp does not turn 'ON' when the ignition switch is placed in the 'ON' position for few seconds.
- The SRS warning lamp stays 'ON' after illuminating.
- The SRS warning lamp comes 'ON'/stays 'ON' while the vehicle is in motion.
- The SRS warning lamp blinks when the vehicle is running.

We recommend to immediately visit TATA MOTORS EV Authorised Service Centre and get the SRS system inspected if any of the above conditions occur.

 **WARNING**

- Never make any modifications to your vehicle. The modifications carried out, but not limited to the vehicle frame, bumpers, front fenders, ride height, suspension, seat belts, interior trims, steering wheel (especially holders), are not acceptable. This will affect the intended performance of SRS.
- Fitment of bull bars, seat covers on seats with airbags etc, is strictly prohibited.
- If you need to make any modifications to accommodate any disability you may have, please contact your TATA MOTORS EV Authorised Service Centre for necessary guidance.
- Do not tamper with SRS in any way. This will lead to unexpected performance of system and may cause serious injury and death.

SAFETY

Airbag Warning Sticker on Front Passenger Sun Visor



The Airbag Warning Symbol on sun visor reminds of the extreme hazards associated with the use of a rearward-facing child restraint on front passenger seat during airbag deployment. It does not mean that a child cannot occupy front passenger seat and use seat belt. Please refer CRS section for recommended seating position for children.

WARNING

Never use a rearward facing child restraint on a seat protected by an active Airbag in front of it, death or serious injury to the child can occur.

Airbags Deployment Conditions

When front airbags should not deploy?

Minor frontal collision: Seat belt (if worn) offers adequate occupant protection in low severity collisions. The airbags are triggered only when there is a collision severe enough to trigger the airbags. Deployment of frontal airbags is not beneficial in low severity collisions.

Side collision: During a side collision, occupants tend to move sideways. Therefore, deploying frontal airbags in such situations will not benefit the occupants. Side airbags and side curtain airbags are specifically designed to reduce the injuries that can occur in side collision.

Rear collision: During a rear collision, occupants tend to move (rearwards)

away from frontal airbags. Therefore, deploying frontal airbags in such situations will not protect the occupant. Head restraints and seat belts provide occupant protection during a rear collision.

Rollovers collision: During a rollover collision, unbelted occupants may float inside the passenger compartment. This will increase the risk of injuries and may prove to be fatal. Wearing seat belts provide highly effective occupant protection during rollover collision. Front airbags, are not designed to deploy in a rollover as frontal airbags cannot offer any protection in rollover collision.

When front airbags/side airbags/side curtain airbags (if equipped) deploy with minor or no visible vehicle damage?

The airbags are triggered only when there is a collision severe enough to trigger the airbags. The extent of vehicle damage is not always the correct indicator for airbag deployment. In some extreme/rare conditions; of rough road driving, running into a curb or hitting other fixed objects; the air

bags may deploy depending upon the severity of collision. In some of these conditions, damage to the vehicle may be minor or not be readily visible.

When front airbags/side airbags/side curtain airbags (if equipped) may not deploy, even with exterior visible vehicle damage?

The airbags are triggered only when there is a collision severe enough to trigger the airbags. The amount of visible vehicle damage is not always the correct indicator for airbag deployment. Some collisions can result in visible damage but with no airbag deployment, because the airbags would not have been needed or would not have provided protection even if they had deployed. Seat belts, if worn, offer adequate occupant protection in such cases.

SAFETY

CHILDREN ON BOARD

WARNING

- Do not leave unattended children in your vehicle.
- During reversing and parking, ensure that children are far away from the vehicle.

WARNING

- Do not put the safety seat belt under your child's arm or behind its back.
- Do not use pillows, books or towels to boost your child's height.
- Do not allow children to stand up or kneel on either the rear or the front seats. An unrestrained child could suffer serious or fatal injuries during a collision.
- DO not install a booster set or a booster cushion, ensure that seat-belt is without any slack or is not twisted.

Child Restraint System (CRS)

TATA MOTORS strongly recommends the use of Child Restraint Systems (CRS) for all children up to 36 Kg and to be placed at recommended positions only (Refer CRS Position table in this section).

ISOFIX

CRS can be installed in the vehicle using seat belts and/or ISOFIX with support leg (if equipped) or ISOFIX with Top Tether (if equipped). These ISOFIX attachment points are located on rear outboard seating locations which enables quick and safe child seat engagement.



ISOFIX with mounting eyelets



Top Tether

Top Tether mounting anchorages are located at backside of rear outboard seats.

The harness system of CRS holds the child in place, and in a collision, acts to keep the child positioned in the seat and reduce the risk of injuries.



Keep children in a forward-facing or rearward facing CRS with a harness until they reach the size or age or weight limit recommended by your CRS manufacturer.

Selection and Installation of CRS

Always select the CRS that complies with latest safety standards (AIS 072 / ECE

R44 / ECE R129). The CRS are classified according to the child's size, height and weight. Select the appropriate CRS for your child. Ensure that the child fits properly in the CRS and it is securely installed in the vehicle. While installing the child seats always adhere to the directions in this Owner's Manual as well as those provided by the child seat's manufacturer.

TATA MOTORS recommends **Joie i-Spin Safe** or **Joie i-Spin 360 R i-size** seats for up to 18 Kg children. These seats are available at TATA MOTORS EV Authorised Service Centre.



i NOTE

TATA MOTORS recommends to keep the highlighted device in close condition while using Joie i-Spin Safe or Joie i-Spin 360 R seat in car.

Installing the Child Seat on Front Passenger Seats

- Adjust the front passenger seat backup to its vertical position as per requirement, so that it can create adequate contact between passenger seat backrest & child seat.

SAFETY

- Adjust the front passenger seat forward or backward as per requirement, so that there could not be any contact between front passenger seat & child seat or child present behind it.
 - If required, adjust the front passenger seat height to its suitable position.
 - While installing child seat on front passenger seating position, adjust the buckle to its suitable position of rotation.
 - While installing forward facing child seat for 15 to 18kg children on front passenger seating position, adjust the front passenger seat to its rear most position.
- and keep it at safe location to reinstall it whenever adult passenger is sitting at that position.
 - While installing child seats on rear outboard seating position, adjust their respective buckles to its required position of rotation.

Installing the Child Seat on Rear Passenger Seats

- If required, adjust the front seat so that there could not be any contact between front seat & child seat or child present behind front seat.
- While installing child seats adjust the rear seat head restraints to its lowermost position or remove it if required

Not Recommended CRS Position



Recommended CRS Position



SAFETY

Recommended CRS Position as Per the Vehicle Matrix

The suitability of seat position for carriage of children and recommended category of CRS is shown in the table as per the child group.

NOTE

The child's life is at risk in a collision if the CRS is not properly secured in the vehicle. Be sure to secure the child in the restraint system according to the manufacturer's instructions.

WARNING

Do not use an infant carrier or a child safety seat that “hooks” over a seat-back, it will not provide adequate protection in a collision.

Recommended CRS Positions (CRS Fastened With A Safety Belt)

Group	Mass Group	Front Passenger with PAB OFF	Front Passenger with PAB ON	Rear Out-board LH	Rear Out-board RH	Rear Centre
0	Up to 10 kg	U	X	U	U	X
0+	Up to 13 kg	U	X	U	U	X
I	9 to 18 kg	U UF	UF	U	U	X
II	15 to 25 kg	UF	UF	U	U	X
III	22 to 36 kg	UF	UF	U	U	X

X: Seat Position not suitable for children in this mass group.

U: Suitable for “universal” category restraints approved for use in this mass group.

UF: Suitable for forward facing “universal” category restraints approved for use in this mass group.

CAUTION

A CRS in a closed vehicle can become very hot. To prevent burns, check the seating surface and buckles before placing your child in CRS.

WARNING

Do not modify CRS in any way.

CAUTION

- Do not install a booster seat or a booster cushion with only the lap strap of the seat belt or a seat belt that is slack or twisted.
- Do not leave any toys or other objects loose in the CRS or on the seat while the vehicle is in motion.

Recommended CRS Positions (CRS That Can Be Used With ISOFIX System)

Group	Mass Group	Category Of Child Seat	Front Passenger	Rear Out-board LH*	Rear Out-board RH*	Rear Centre
0	Up to 10 kg	E	X	IL	IL	X
0+	Up to 13 kg	C, D, E	X	IL	IL	X
I	9 to 18 kg	D, C, B, B1, A	X	IL IUF	IL IUF	X
II	15 to 25 kg		X	IL	IL	X
III	22 to 36 kg		X	IL	IL	X

IL: The seat is suitable for the ISOFIX child seats with “Semi-Universal” approval.

IUF: The seat is suitable for forward facing child seats and is permitted for use in this weight category.

X: The seat is not equipped for the ISOFIX system.

*Rear outboard seating positions are suitable for ISO/R3, Class C CRS.

SAFETY

After a collision, we recommend to get seat belts, seats, ISOFIX and top-tether anchorages (as may be applicable) investigated at TATA MOTORS EV Authorised Service Centre.

Each CRS should be used for one child only.

Passenger airbag can be turned OFF manually through switch provided on side face of the dashboard at front passenger side. Visual signal of passenger airbag ON or OFF is indicated on the roof console.

When passenger airbag is ON, a rearward facing child seat shall not be installed on the front passenger seat.

When passenger airbag is OFF, a forward or rearward facing child seat can be installed on the front passenger seat.

While installing a rearward facing child seat on the front passenger seat, passenger airbag must be OFF.

Refer images in PAB Switch section.

WARNING

If the airbag SRS warning indicator in the instrument cluster illuminates continuously, it means that there is malfunction in the system. Remove the CRS from front passenger seat and contact your TATA MOTORS EV Authorised Service Centre.

Child Lock



Child lock are provided on both rear doors. It is used for safety of a child.

Child safety lever to be used for safety of child for preventing them to open rear door while sitting in passenger seat to avoid accident while vehicle is moving.

Both the rear doors of the vehicle are provided with a child proof lock. Push the lock lever (located on vertical face of the door) downward before closing the door. The door which has been locked by activating

the child lock cannot be opened from inside. It can be opened only from the outside.

 **NOTE**

Lift the lock lever upward to deactivate the child lock when not required.

SAFETY

ADDITIONAL SAFETY FEATURES (if equipped)

These are additional safety features. For tell-tale related information, please check Warning and Indicator section from this Manual.

Electronic Stability Program (ESP)

It monitors stability and traction. If the vehicle is from the direction desired by the driver, one or more wheels are getting braked to stabilize the vehicle. ESP assists the user when the vehicle is pulling away on wet or slippery roads. ESP can also stabilize the vehicle during braking and acceleration. ESP warning lamp glows on instrument cluster when the ignition is ON. It goes off after few seconds if system is healthy.

Anti-Lock Braking System (ABS)

ABS regulates brake pressure in such a way that the wheels do not lock when you brake. This allows you to continue steering the vehicle when braking. The ABS warning lamp in the instrument cluster lights up when the ignition is switched on.

It goes OFF after a few seconds if the system is healthy.

While Braking

In case of emergency braking, press the brake pedal fully. This allows the ABS to regulate braking force and maintain directional control of vehicle. When ABS is active driver may feel brake pedal pulsating and very low (ABS) motor activation noise from engine compartment which is normal during braking.

WARNING

- If ABS malfunction, ABS may not shorten the distance in all situation.
- ABS system will have the effect of increased stopping distance due to conditions such as gravel, pot holes, slippery surfaces, wet road, ground covered with snow etc.
- Travelling on bad road, panic braking brake pedal may become hard, this is due to ABS system taking control. ABS will not compensate for bad road, weather conditions and poor driving judgment. Always drive

carefully in adverse weather and traffic conditions.

- Always keep safe distance and adhere to speed limits.

Electronic Brake Force Distribution (EBD)

EBD monitors and controls the brake pressure on the rear wheels to improve driving stability while braking. EBD provides optimal braking pressure distribution between front and rear wheels to optimize braking distance and to ensure vehicle stability by means of lowering braking pressure at rear wheels.

WARNING

- If the EBD is faulty, The ABS Warning lamp along with the Brake Malfunction lamp remains ON in the Instrument cluster.
- If ESP, ABS and EBD malfunctions, warning lamp will glow continuously. In such cases, do not panic drive the vehicle carefully and immediately

visit TATA MOTORS EV Authorised Service Centre to rectify the issue.

Electronic Traction Control (ETC)

The Electronic Traction Control system function (ETC) is designed as a slip control system to prevent the driven wheels of a vehicle from excessive wheel slip.

Cornering Stability Control (CSC)

It supports / stabilizes vehicle during partial braking on the curves by reducing pressure at required inner wheel of the vehicle. This helps to reduce the probability of vehicle over steering during cornering.

Roll over Mitigation (ROM)

The main feature of the Roll over Mitigation function is the detection of a rollover critical situation and to prevent the vehicle rollover.

Brake Disc Wiping (BDW)

Water on the brake disc leads to a delay in brake response time. The purpose of the function Brake Disc wiping is to remove the moisture when driving in wet

conditions automatically & this will help to get quick response from Brakes and have a better deceleration.

Electronic Brake Pre-fill (EBP)

The Electronic Brake Prefill (EBP) function reduces the air gap of the brake pad and the brake disc. The function is triggered after a sudden release of the accelerator pedal due to an unexpected emergency brake situation. By actively pre-filling the brake system the brake response time is reduced and results in a shorter stopping distance.

Hydraulic Brake Assist (HBA)

In an emergency situation, user may not utilize the full available performance of the brake system, as they may apply brake too soft due to Panic. The HBA function detects the critical situation and builds up additional brake pressure to reduce the braking distance.

Hydraulic Fading Compensation (HFC)

To compensate the hydraulic fading in the brake circuit while applying brake under

extreme operating condition which leads to excessive temperature rise of brake fluid. The moment temperature rises, the HFC system automatically compensates for this by increasing the hydraulic pressure in relation to the force applied to the pedal.

Dynamic Wheel Torque by Brake (DWT-B)

Dynamic Wheel Torque Vectoring system enables the driver to steer the vehicle exactly as intended by shifting propulsion torque via braking. It achieves high off-road performance even on the toughest roads.

Hill Hold Control (HHC)

Hill Hold Control is a comfort function. The main intend is to prevent the vehicle from rolling backwards while driving off up-hill on an inclined surface.

Panic Brake Alert (PBA)

Panic brake alert warns the surrounding vehicles when an emergency or heavy braking takes place. The function will trigger Hazard lamps automatically, which

SAFETY

will provide an immediate warning to vehicles directly behind and nearby. With PBA, surrounding drivers and vehicles have more time to respond against slow-down vehicles. By providing additional warning to improve road safety, PBA reduces the amount and degree of injuries caused by rear end collisions that occur during heavy braking.

After Impact Braking (AIB)

- In the event of primary collision there are chances that vehicle can no longer be safely controlled. Accident analysis has shown that an active brake intervention would mitigate the effect of the subsequent collisions.
- After impact braking system is activated automatically and brakes the car in a safe manner to mitigate secondary collision.
- Hazard & brake lights are triggered to intimate surrounding users of an emergency situation. Warning lights will continue flashing after vehicle comes to a standstill.

- The driver can override the system by depressing the brake/acc pedal if there is a risk of being hit by following traffic.
- The basic assumption is that the brake system is intact after the primary impact.
- Mitigate impact/severity of subsequent collisions.

Integrated iVBAC

Introducing the Intelligent Vacuum-less Boost & Active Control (iVBAC) a cutting edge brake technology designed for hybrid and electric vehicles. Unlike traditional systems, the iVBAC operates vacuum-free, enhancing reliability and simplifying maintenance.

This system not only supports regenerative braking but also functions as an Electronic Stability Control (ESC) unit, seamlessly integrating Anti-lock Braking System (ABS), Traction Control, and Stability Control functionalities. When you apply the brakes, the iVBAC translates your input into precise brake pressure, ensuring

a smooth and controlled experience.

ANTI-THEFT DEVICE IMMOBILIZER

Immobilizer system is designed to prevent vehicle theft by electronically disabling the vehicle ignition system. The vehicle can be started only with vehicle's original Immobilizer ignition key which has an electronic identification programmed code.

NOTE

Use only one key, the other should be kept in a safe location. Note down "key Tag no." information (and keep it safe) which is required while getting new/spare keys. Remember that it is not possible to prepare new/spare keys without the "key Tag number." Take precaution about key, as without key vehicle cannot be started.

Vehicle Condition	Immobilizer Lamp Status	Vehicle State	Meaning / Function Of The State
Ignition OFF	Blinking	Locked	Vehicle Immobilized and awaiting electronic key
Ignition ON	OFF	Unlocked	Normal condition and ready to start the vehicle
Ignition ON	ON	Locked	<ul style="list-style-type: none"> • Problem with key (wrong key used to start vehicle) • Problem with Immobilizer system. Contact TATA MOTORS EV Authorised Service Centre.
Ignition ON	Blinking	Unlocked	Contact TATA MOTORS EV Authorised Service Centre immediately.

HIGH VOLTAGE BATTERY SYSTEM

Temperature Limits

Battery pack and vehicle can operate safely in limits from -22°C to 55°C.

NOTE

To control the battery temperature of the high voltage battery the air conditioner is used to cool down the battery and may switch on automatically without request from control panel which may generate noise from operation of the air conditioner compressor and cooling fan.

HV Battery Life & Maintenance

This Vehicle comes with a standard battery warranty as mentioned in warranty section. Regular service of the vehicle and charging protocol to be followed to maximize the battery life.

Energy Information

The vehicle battery pack has a maximum energy as specified in Technical Specifi-

cation. Energy retention capacity deteriorates over several cycles of usage and hence range deterioration happens over-time.

This decrease in range during the end of life of battery is expected and is not considered as a malfunction of the battery pack. During these conditions, it is recommended to contact TATA MOTORS EV Authorised Service Centre.

Brake Energy Recovery System

The vehicle features energy regeneration system, which regenerates expended energy during coasting or braking during the drive. This system allows the battery to be recharged under the above mentioned conditions.

Please note, the regeneration system does not fully recharge the battery, it only provides a chance to recover a portion of energy that would be lost during braking. When you release the accelerator or press the brake pedal, energy flows from wheels to high voltage battery, thereby charging it.

Regeneration is done by converting driving force (kinetic energy) into electrical energy that is stored in the Li-ion battery while the vehicle is decelerating or being driven downhill. This is called regenerative braking

Heavily Discharged High Voltage System

In the case of a heavily discharged HV battery, there is a chance that the low voltage battery is discharged as well. In this case, please contact your nearest TATA MOTORS EV Authorised Service Centre.

WARNING

Do not try to jump start the vehicle or tow the vehicle without guidance from the service assistant.

Heated High Voltage Battery

In such a condition, the battery has safety logics to limit the performance or disconnect by itself with prior warning. The vehicle should be stopped and allowed to cool down and contact TATA MOTORS EV Authorised Service Centre.

BATTERY AND COMPONENT

Long Storage of HV Battery Pack

The HV battery undergoes discharge at a rate of approximately 3% over a period of 30 days in storage. Do not allow the vehicle to be discharged to 0% in storage. It is recommended that the vehicle must be charged to a charge level in between 30% to 50% before leaving the vehicle for long time storage. After this time period the vehicle must be charged to 100% using Normal Charging before use.

High Voltage System Failure

In the case of high voltage system failure, which may arise due to various reasons, contact TATA MOTORS EV Authorised Service Centre for further assistance.

Predicting Energy Usage

The vehicle battery energy usage is displayed in the instrument cluster in the form of estimated range. This range is updated by the system algorithm, depending on the driving conditions.

Displayed range in the instrument cluster is a tentative number based on drive route, driving pattern and usage pattern

history over the past drives. It is recommended keep a 20km buffer in estimated range before planning the trip

Disposal

The disposal of an HV Battery must be done with utmost care and will be carried out by TATA MOTORS EV Authorised Service Centre after sales service at the end of the battery life time or if the battery pack has passed its warranty period.

NOTE

- *It is advised to contact TATA MOTORS EV Authorised Service Centre which shall guide & help in dismantling, handling and disposal through agencies who are certified by central/state pollution control board & obtain certificate of disposal from these agencies as proof of sustainable disposal.*
- *If you decide not to use the recommended TATA MOTORS EV Authorised service center or TATA MOTORS EV Authorised Workshop to dispose of your high volt-*

age battery, the responsibility of the consequences of environmental pollution or accidents must be borne solely by you, the owner of the vehicle.

- *Customers who wish to dispose of battery by themselves shall deal only with registered entities (list of these is available on the CPCB/SPCB website) after duly verifying validity of necessary registration documents. After disposal the EPR certificate has to be obtained by the customer from the entity. It is request that customer shall provide this certificate to nearest TATA MOTORS EV Authorised Service Centre which is to be kept for records & submitted to central pollution control board as proof of disposal according to policy guidelines.*

WARNING

EV battery contains materials like Lithium Iron, graphite, plastic & steel etc which can have impact on environment and are harmful if not handled/dropped of carefully. There is a risk of severe burns and electrical shock that may result in serious injury while additionally posing a risk of environmental damage.

CAUTION

Keep the following things in mind to prevent damage of the battery pack:

- Avoid exposure of the vehicle to extreme environmental temperature for extended period of time.
- Do not leave the vehicle for longer period when High voltage battery is near zero SOC. Follow the long duration storage guideline.
- Do not use the High voltage battery for any other purpose.

- The capacity of the High voltage battery will decrease with time and usage to hold charge like all such batteries. As the battery ages and capacity decreases, this will result in a decrease from the vehicle's initial mileage range. This is normal, expected, and not indicative of any defect in your High voltage battery.
- When the HV Battery reaches the end of its life cycle, the charging capacity or State of health (SoH) reduces. During such decrease in charge capacity and range of vehicle, contact TATA MOTORS EV Authorized service centre and get the SoH of Battery pack get inspected.
- One full slow charging after every 4 Fast charging cycle is recommended for regular charging.
- If over time the maximum charge capacity and the maximum electric range begin to degrade, contact TATA MOTORS EV Authorised

Service Centre for inspection and maintenance.

- If the vehicle is involved in a collision, we recommend that you contact an authorized TATA MOTORS EV dealer to inspect if the high voltage battery is still connected or damaged in any way.
- The HV battery capacity of the high voltage battery may decrease when the vehicle is stored in high/low temperatures.
- Electric range may vary depending on the driving conditions, even if the charge amount is the same. The high voltage battery may expend more energy when driving at high speed or uphill. These actions may reduce the vehicle electric range.

BATTERY AND COMPONENT

TIPS TO CONSERVE BATTERY LIFE

1. Battery Charging

It is advisable to charge the vehicle up to 100%. This ensures accurate SoC calculation and consistent energy content intake during charging. Charging to 100% also maintains battery health for longer time and ensures better range throughout the life cycle of the vehicle.

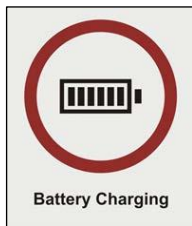

It is also advisable to slow or home charge the vehicle to 100% as much as possible. Slow Charging and full charging is the best way to charge your vehicle to maintain the health of the high voltage battery.

After every 4 fast charging cycles, it is advisable to slow or home charge the vehicle to 100% SoC.

2. Cell Balancing or equalization

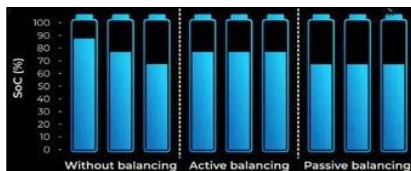

Cell balancing or equalization and SoC calibration happens during charging, especially at higher SoC, >90%. This causes charging to take longer time above 90%. Allow the vehicle to reach 100% SoC before terminating the charging session, as both cell balancing and SoC calibration are essential steps for any battery to perform optimally for a prolonged time.

3. Extreme Temperatures

Extreme temperatures impact upon how well a battery can maintain its level of charge. Avoid charging the high voltage battery when it is hot and vehicle is



driven for long distances especially in summers. Allow vehicle temperature to cool down before charging. It is always better to charge EV when ambient temperature is low especially at night.

4. Vehicle Parking

Avoid parking vehicle in direct sunlight for long duration. Try to park it under shade, tree etc. This helps in keeping battery temperature low resulting enhance battery life over the life cycle.



INSTRUCTIONS TO FOLLOW**Instructions:**

- It is recommended to charge the vehicle to 100% every time, whenever vehicle is being charged.
- Avoid charging vehicle under heavy rain / thunderstorms.
- Avoid driving vehicle below 10% SoC.
- Make sure the charge station's supply cable is positioned so it will not be stepped on, tripped over, or otherwise subjected to damage or stress.
- There are no user serviceable parts inside the charging gun. Contact TATA MOTORS EV Authorised Service Centre should you experience any problems with the charging gun. Do not attempt to repair or service the charge station or charging gun yourself may result in injury.
- Do not operate your charge station and gun if it or the supply cable is visibly damaged. Contact your Service Representative for service immedi-

ately. Refer to the 'Emergency and Breakdown' section in this manual for information on the Service Representative in your area.

- Do not place fingers inside the coupler on either end of the charging gun.
- Do not allow children to operate this device. Adult supervision is mandatory when children are in proximity to a charge station that is in use.
- Not for use in commercial garages.
- Slow Charging only happens in park brake engaged condition. So always keep the park brake engaged during a charging session.
- Change of vehicle state (Ignition OFF to Ignition ON or vice-versa) should be avoided while charging
- Post switch off the charger, provide min 5 seconds for touching and pulling out the gun.
- If the charging gun removed and reinsertion required it could be done after at least 10 seconds of removal of the

charging gun from Socket.

- Do not disengage/play around with the Park brake/hand brake while vehicle in fast charging condition.
- Overcurrent and leakage current protections are given in the home charging box and charging gun. The RCBO should always be in ON state during normal charging use-case and there should be no error (Red) LEDs on the charging gun. In case any tripping of RCBO is observed or error LEDs start blinking on the Charging gun, please contact TATA MOTORS EV Authorised Service Centre.
- Home charging box comes with a key and lock. It is recommended to lock the box during overnight charge or when the charging box is not in use to avoid misuse of charging point.

 **WARNING**

Unplug both couplers of your Portable Charging Gun before cleaning.

CHARGING

NOTE

During normal operation, the charging gun or couplers may feel warm. If either coupler or the charging gun feels hot during charging, unplug the gun and have a qualified electrician inspect the connections before you continue charging.

WARNING

The charger generates electromagnetic waves that can seriously impact medical electric devices such as an implantable cardiac pacemaker in a person. When a person has an implant like the one mentioned above, make sure to ask the medical team and the manufacturer whether charging your EV will impact the operation of the medical electric device implant. In such case, do not go near the vehicle when it is charging.

CAUTION

Do not use a damaged charging station, plug point or charging port. Using the charger with a worn or damaged port may result in unanticipated consequences.

WARNING

- Ensure that the charging gun is always stored in a safe place. Do not expose it to rain or wet conditions. Avoid pouring or dripping water or other liquids over it.
- If water penetrates the electrical devices, the risk of electric shock increases. Ensure that all plugs and cables are free of moisture before using the charging gun. Never connect the charging gun to the mains with wet or moist hands or when the charging gun is wet.

NOTE

Charging should be done in Ignition OFF state.

NOTE

Charging station and domestic plug point must be approved/certified by a qualified electrician before using the charging gun. Coupler Receptacle has to have proper Grounding, electrical connection and has to contain a Residual-Current Circuit Device (RCD).

CAUTION

- Make sure that the device is always stored in a safe place. Do not expose the device to rain or wet conditions.
- DO NOT use this product if the EV charge connector/cable is damaged.
- During charging the vehicle must not be exposed to rain, lightning and snow.

IMPORTANT TIPS**Do's and Don'ts**

- Do not direct high pressure washer fluid/ water jets (Pressure above 0.5 bar) at electrical devices and connector during washing. This is to prevent malfunction/failure of electrical system due to water ingress. No High pressure washing in motor compartment, Under-floor battery pack and CCS Charging port.
- Always check the SoC level before start of journey & ensure car is adequately charged. You may check the SoC level on the mobile app also.
- Remote AC command not to be executed through mobile app while/during the charge initiation process.
- If AC is switched ON remotely using Zconnect, it is required to switch it off using the Zconnect app before unlocking the vehicle. If it is not followed, the vehicle requires two ignition ON cycle to move as it will not move in the first ignition ON cycle.
- The charging gun provided for home

charging has to be stored safely and securely in the trunk of the vehicle or has to be plugged on to the Home Charging Box in locked condition.







- The wall box charging unit is also used for slow or home charging. It comes with a key and lock. It is recommended to lock the home charging box when the vehicle is kept for overnight charging or when nobody is around while the vehicle is being slow charged. This ensures that the charging unit along with the charging gun cannot be misused or stolen.
- Wet surfaces are good conductors of electricity. Though the vehicle is equipped with safety mechanisms to protect users, it is advisable to take a few precaution while plugging in for charging. Hence, before charging, ensure that the power source socket, the charging gun and the charging port (CCS2) port in the vehicle are dry. Also ensure that you are standing on dry ground and your hands are dry as well while using the high voltage charging equipment.

- Usage of damaged cables, Power Source socket and vehicle side CCS2 port must be avoided as they may result in electrical hazard and inconsistent charging experience.
- While plugging in for home charging, ensure power source is off. Subsequently ensure charging gun is connected at both ends - One at power source and the other at vehicle's CCS2 port. Then switch ON the power source switch to commence charging. Confirm that the vehicle is charging from the green charging telltale displayed on the instrument cluster. The cluster remains ON to display charging status for 60 sec after the start of charging.
- If charging gun is removed before 100% charging and again needs charging up to 100%, it is advisable to wait for at least 10 seconds before reinserting the gun in the charging port.
- Once charging is complete and gun is removed from the charging port, it is advisable to pause for 30 sec before switching on the car to start driving.

CHARGING

- When the vehicle is shut off after drive, it is advisable to pause for at least 10-15 sec before charging. It allows the vehicle's electrical system time to de-energize and stabilize before the charging commences.
- Comply with the following in order to prevent electrical shock when charging:-
 - Use a waterproof charger.
 - Do not touch the charging connector and charging plug with your hands wet, or do not stand in water or snow while connecting the charging cable.
 - Be careful when there is lightning-Be careful when the charging connector and plug are wet.
 - Immediately stop charging when you discover abnormal symptoms (smell, smoke, etc.).
- Replace the charging cable if the cable coating is damaged to prevent electrical shock. When connecting or removing the charging cable, make sure to hold the charging connector handle.
- Only use the certified charging cable. If you use a separate extension cable such as a reel or use an uncertified cable, it may cause abnormalities of electrical outlets, leading to fire or explosion.
- If you pull the cable itself (without using the handle), the internal wires may be disconnected or get damaged. This may lead to electric shock or fire.
- Do not leave the vehicle with the charging door open. An open charging door may indicate that the vehicle door has been unlocked and may be subject to vehicle theft.
- Always keep the charging connector and charging plug in clean and dry condition. Be sure to keep the charging cable in a condition where there is no water or moisture.
- Make sure to use the designated charger for charging the electric vehicle. Using any other charger may cause failure.
- Before charging the battery, turn OFF the vehicle.
- When the vehicle is switched OFF while charging, the cooling fan inside the motor compartment may automatically operate. Do not touch the cooling fan while charging.
- Be careful not to drop the charging connector. The charging connector can be damaged.
- Do NOT use an extension cord, when using the L1-Trickle charger, as this may overheat and/or cause damage.
- When charging or right after charging the high voltage battery, the cooling will be made using air conditioner system in order to control the high voltage battery temperature. At this time, the Noise might occur by the air conditioner compressor and cooling fan, but this is due to normal operation.

TYPE OF CHARGING

S.N	Types Of Charging	Charging Component Specification	*Charging Time	Charging Time In SoC Band	Charge Gun	Power Source
1	Normal/AC Charging	<ul style="list-style-type: none"> Nominal Voltage: 230V AC RMS single Phase 50Hz Power Rating: 3.3kW AC RMS Rated Current 13A AC RMS 	17.5 Hrs. (Option I) 21 Hrs.(Option II)	10-100%		
2	AC Charging (WMU)	<ul style="list-style-type: none"> Nominal Voltage: 230 V AC RMS single Phase 50Hz Power Rating: 7.5kW AC RMS Rated Current 32A AC RMS 	6.5 Hrs. (Option I) 8.7 Hrs. (Option II)	10-100%		
3	Fast / DC Charging	<ul style="list-style-type: none"> Power Rating: 50kW Charging station voltage capability should be greater than or equal high voltage battery pack nominal voltage. 	45 mins.(Option I) 50 mins.(Option II)	10-80%		

*Under standard test condition.

CHARGING

1. Normal / AC Charging

In electricity grid, electric power is AC (alternating current) by nature. However, electric power in battery is DC (Direct Current) by nature. Hence, to charge an electric car by AC grid, power has to be converted from AC to DC. And to convert AC power to DC power On-board Charger is used. This type of charging is called Normal charging/AC charging.

Normal charging is recommended for usual charging of the vehicle. This charging method is most suitable for parking spots where the car will stay parked for longer duration of time.

Precautions for Normal Charging

1. Proper maintenance of earthing pit is must. Add water & add salts at regular intervals into the earth pits in order to maintain the value of earth resistance. Check annually the condition of the electrodes so as to add or replace electrodes.
2. The electrical socket used for EV charging and its associated wiring

should be able to supply 15A dedicated load continuously.

3. Vehicle charging port must be free of dust, water or snow while connecting the charging gun; if not proper cleaning method must be used to remove dust, water and ice.
4. Don't try to pull off the charging gun during charging.
5. Don't pull out the charging gun if it is in locked condition as excess force can break or damage the locking mechanism.

Normal Charging Procedure

1. Engage the Parking Brake. (Charging won't start if parking brake is not engaged).

2. Connect the plug to AC power socket.



3. DO NOT plug into a power strip.

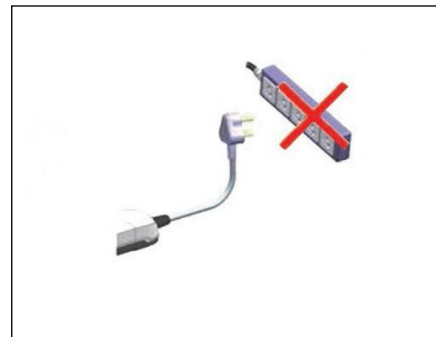

4. Open the protective cap on Charging Gun.



5. Press the 'Charging opening switch' to open the charging inlet flap.



6. Open the protective cap on Charging Inlet.

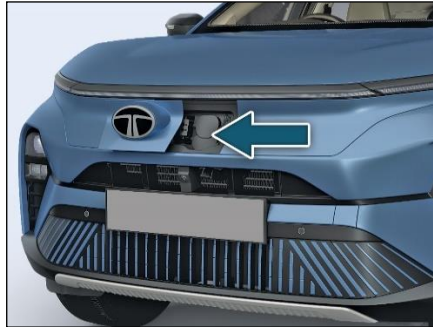

7. Before connecting the charging gun to vehicle charging socket, make sure the gun lock is released.

⚠ CAUTION

- If the Gun Lock is not released please don't insert the Charging Gun forcefully into the socket. It may damage the Charging Socket.
- Don't use the electric connection with extension or power strip for the

slow charging or AC charging of the vehicle, this will lead to heat up the cables and charging gun. Prolong charging IN such condition may lead to melting of wire and charging gun.

8. If the actuator is engaged and the gun is not getting inserted properly, contact TATA MOTORS EV Authorised service centre.
9. Remove any dust on the Charging Gun and Charging Inlet. Connect the charging gun to vehicle AC Charging Inlet.



CHARGING

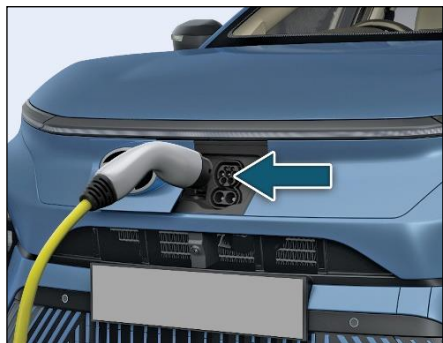

10. Switch on the AC supply.
11. Charging Gun will be locked after switching on the AC supply. You will hear a “click” sound, when the gun is connected correctly.

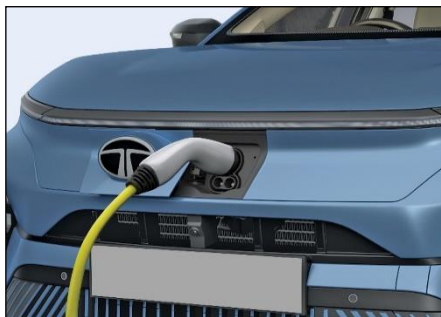

*i*NOTE

When vehicle is in Charging Mode, it will not go in Drive (D) or Reverse(R).

12. Normally the car starts automatically charging. If not, please refer ‘Trouble-shooting Guide for Normal Charging’ table.
13. Open the door and see instrument cluster for State of Charge, Time to Charge and Gun connection status.
14. In case the park brake is not engaged or partially engaged the charging

won't start and ‘Engage Park Brake to start charging’ message will be displayed on instrument cluster.

*i*NOTE

Infotainment and cabin cooling can be used during charging of the vehicle by putting the vehicle in Ignition.

15. To stop the charging, switch off the AC power supply.
16. The charging gun will be unlocked after switching off the AC supply and pressing charging gun unlock switch.

*i*NOTE

If the gun does not gets unlocked in first attempt of pressing fascia switch, repeat the operation.

17. Pull out the plug.

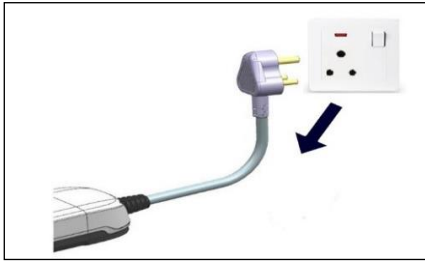

18. Put on the protective caps on both Charging Gun and Vehicle Inlet.

iNOTE

In emergency charging shutdown conditions, Gun won't be unlocked. Contact TATA MOTORS EV Authorised Service Centre.

iNOTE

Once Normal /Fast charging is completed, 90 seconds of time gap is required before the vehicle can be started. After turning off the vehicle, wait for four seconds if you want to start the vehicle again.

Emergency charging Gun unlocking

In case of electrical malfunction, you can unlock the Charging Gun from inside of bonnet as per procedure given below.

1. Open the bonnet.
2. Pull the cable of charging gun unlocking, as shown below picture.



3. Then pull out the charging gun.

Emergency Charging flap opening

In case of electrical malfunction, you can unlock the opening flap from inside of bonnet as per procedure given below

1. Open the bonnet.
2. Then pull the cable of charging flap, as shown below picture.



4. Move the charging flap at your left, pull the charging cap.

CHARGING



If charge cap needs replacement, make sure that it is replaced by a genuine cap at TATA MOTORS EV Authorised Service Centre only.

For closing push the charging flap, till it gets locked.

Normal Charging Control Box

Indications:



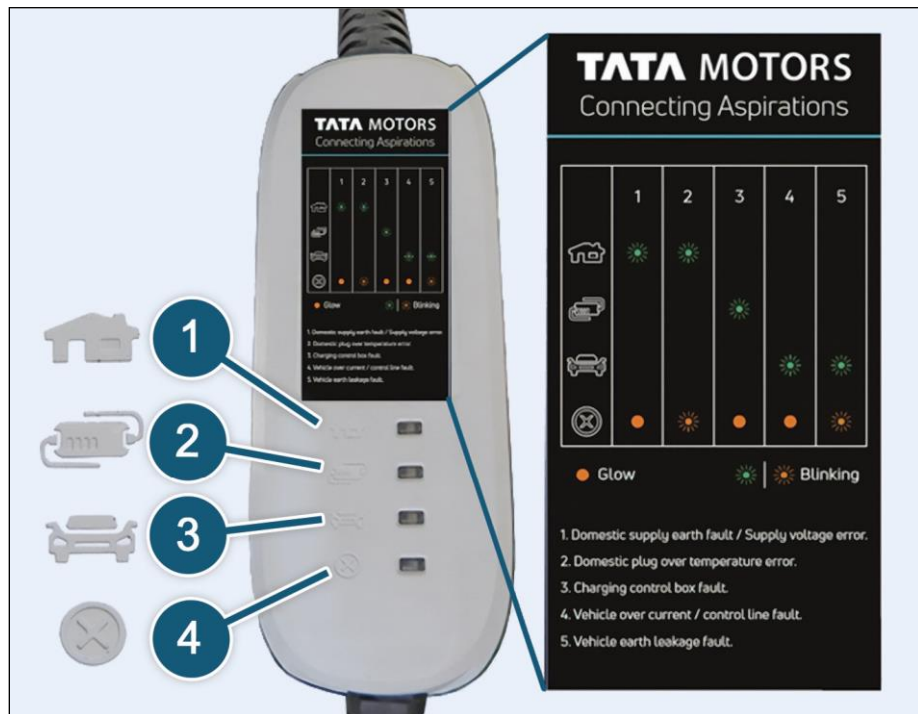





1. Home
2. Control Box
3. Vehicle
4. Fault





CHARGING

Troubleshooting Guide for Normal Charging

Refer the below table if charging is not starting or if it stops abruptly. The below symbols of 'House', 'Control Box', 'Vehicle' and 'Fault' can be seen on the control box beside the respective LEDs.

Fault Category	Indication	Home	Control Box	Vehicle	Fault	Recommended Action
						
Interface fault in home		Blink	Off	Off	On	Improper earth connection. Check the earth pit. Short circuit between PE and phase. Error in domestic supply side. "Stop Charging"
		Blink	Off	Off	Blink	AC voltage is either less than 190V or more than 250V. Error in domestic supply side. "Stop Charging"
Control box fault		Off	Blink	Off	On	Proper connection of plug and socket should be ensured. Also, check socket rating and use 15A socket Contact TATA MOTORS EV Autho- rised Service Centre
		Off	Blink	Off	Blink	

Fault Category	Indication	Home	Control Box	Vehicle	Fault	Recommended Action
Vehicle box		Off	Off	Blink	On	Go to nearest TATA MOTORS EV Authorised Service Centre
		Off	Off	Blink	Blink	

Legend

 - Blink

 - Off

 - On

CHARGING

2. AC Charging (Wall Mount Unit)

This type of charging will help customer to improve the charging time for vehicle charging.

AC (WMU) Procedure

1. Parking brake should be in engage condition (Charging won't start if parking brake is not engaged).
2. Press the 'Charging opening switch' to open the charging inlet flap



3. Open the protective cap on Charging Inlet (AC side).

4. Remove the charging gun from the WMU. (WMU will be separately installed at customer end)



5. Open the protective cap on WM Charging Gun.



6. Before connecting the WMU charging gun to vehicle charging socket, make sure the gun lock is released.
7. If the actuator is engaged and the gun is not getting inserted properly, contact TATA MOTORS EV Authorised Service Centre.
8. Remove any dust on the Charging Gun and Charging Inlet. Connect the WMU charging gun to vehicle ACWMU Charging Inlet.



9. Scan the RFID provided, on the WMU to start charging.

10. Charging gun will be locked automatically. You will hear a “click” sound, when the gun is connected correctly.
11. Normally the car starts automatically charging. If not, please refer ‘Troubleshooting Guide in WMU’s owners’ manual.

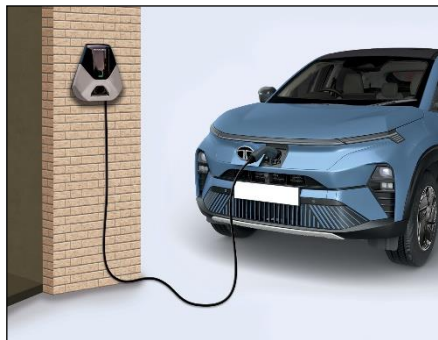

12. Open the door and see instrument cluster for State of Charge, Time to Charge and Gun connection status.
13. To stop the charging, scan the RFID on WMU.

14. The charging gun will be unlocked after pressing the fascia switch on the dashboard panel. Pull out the gun.
15. Put on the protective caps on both Charging Gun and Vehicle Inlet. Place the Charging gun back and close the charging inlet flap.

3. Fast / DC Charging

- Fast charging of electric vehicle is achieved by using Fast/DC charging stations; they convert the AC power from the grid to DC power and can directly charge the HV battery pack thus by passing the On-Board Charger.
- Fast charging can be done wherever Fast/DC charging station is available. User can charge at high speeds at public charging stations.
- Electric vehicle can be fast charged using any fast charging station or equipment compliant to Combined Charging System standard having Type 2 connector (CCS Type 2).

*i*NOTE

Battery performance and durability can deteriorate if the fast charger is used constantly. Use of Fast Charging should be minimized in order to help prolong high voltage battery life.

After a maximum of four fast charging cycles, the battery pack you must use Normal charging to 100% State of Charge for the optimum performance of the high voltage battery pack.

*i*NOTE

Depending on the condition and durability of the high voltage battery, charger specifications, charger rating, and ambient temperature, the time required for charging the high voltage battery may vary.

CHARGING

Fast Charging Procedure

1. Engage the Parking brake. (Charging won't start if parking brake is not engaged).
2. Pull out the Charging Gun from DC/Fast Charging Station.
3. Open the protective cap on Charging Gun.



4. Pull the 'Charging-inlet Flap Open Lever' to open the charging door.
5. Open the charger-inlet flap.

6. Before connecting the charging gun to vehicle charging socket, make sure the gun lock is released.

CAUTION

If the Gun Lock is not released please don't insert the Charging Gun forcefully into the socket. It may damage the Charging Socket.

7. Remove any dust on the Charging Gun and Charging Inlet.
8. Connect the charging gun to vehicle Charging Inlet.
9. Switch on the DC charging station supply.

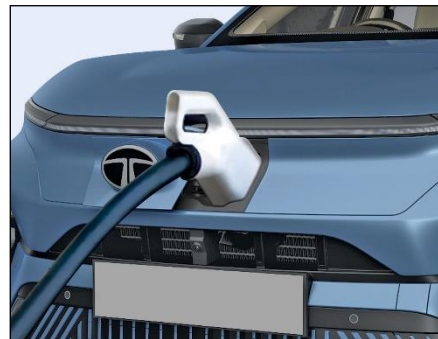

10. Charging Gun will be locked after switching on the DC charging station.
11. You hear a "click", when the Gun is connected correctly, Click sound is because of Gun locking after supply is switched on.
12. Normally the car starts automatically charging. If not, please refer Charging Gun's Fault Indication & Indication Priority Table on the charging station.



*i*NOTE

When vehicle is in Charging Mode, it will not go in Drive (D) or Reverse (R).

13. To know the State of Charge, Time to Charge and Gun connection status please see instrument cluster. This status is displayed only when driver door is opened.
14. SoC can also be identified from front of vehicle on CPL.
15. In case the park brake is not engaged or partially engaged the charging

won't start and 'Engage Park Brake to start charging' message will be displayed on instrument cluster.

*i*NOTE

Infotainment and cabin cooling can be used during charging of the vehicle by putting the vehicle in Ignition.

16. To stop the charging, switch off DC charging station.
17. The charging gun will be unlocked 15 seconds after switching off the supply from DC charging station. For fast charging no fascia switch input is required. It unlocks automatically.
18. Put on the protective caps on both Charging Gun and Vehicle Inlet.

*i*NOTE

If you remove the charging gun from the vehicle and if you wish to reinsert the gun to recharge the vehicle, please wait for at least 10 seconds before charging gun is plugged again.

*i*NOTE

In emergency charging shutdown conditions, Gun won't be unlocked. Contact TATA MOTORS EV Authorised Service Centre.

CHARGING

V2X CHARGING

The V2X charging system offers a flexible and energy exchange method for charging electric vehicles (EVs) without the need for charging stations. A new framework for vehicle-to-vehicle charging technology is introduced that can work plug-in electric cars.



Below parcel tray LH side in luggage compartment.

Vehicle Ignition OFF / ON Conditions

The transponder in the ignition key carries a Unique Identification Code (UID). The vehicle unlocks when the code on the key matches with the code on the Battery Management System (BMS). In case of PEPS variant, Immobilizer function is provided by PEPS ECU.

Vehicle To Vehicle Charging (V2V)



V2V Gun

Vehicle Ignition OFF state

1. User can decide the discharge SOC limit of the source vehicle (donor) and can preset the SOC limit in infotainment before starting the V2V function.
 - Since infotainment system won't be awake in Ignition OFF state, Limit can be set only in ignition ON or Crank on condition.
 - Discharge SOC Limit cannot be changed during the V2V function.
 - In case if no limit is set by the user, 30% SOC will be consider as default discharge SOC limit.
2. Keep both sink (recipient) and source (donor) vehicle nearby and ensure maximum up to 3m distance between the charging inlets of the vehicles.
3. Make sure to keep the vehicles and the V2V charger in dry environment/in shade
4. If the Source/sink vehicle is in OFF state, Open/close the door or if vehicle is in locked state Press RKE unlock Button and open the door to wake up

- the vehicle control unit. Once wakes up, Vehicle control unit will remain in wakeup state for 120sec.
5. Remove the caps & connect the V2Vgun to the source and sink vehicle within 120sec of step 4. Check the labels on the V2V gun and make sure that the V2Vgun side labelled as “source” should connect to the source vehicle & the other end labelled as “sink” should connect to the sink vehicle. If user couldn’t connect the V2V gun within 120 sec of step4. Remove the Gun completely and repeat from step 4.
 6. Make sure park-brake/EPB is engaged.
 7. Ensure V2V gun is connected to both vehicles and press the V2X switch of source vehicle within 120 sec of step 5 to start the 220V AC power supply and to charge the sink vehicle. If user couldn’t press V2X switch within 120 sec of successful step 5. Remove the Gun completely and repeat from step 4 to initiate the V2V function again.
 8. Check for the tell-tale indication frequently when the V2V function is in progress to ensure there is no interruption/fault.
 9. V2V function will stop from source vehicle side, if there is no energy dissipation has happened for 100secs from successful step 7. In this case, remove the gun completely and start from step 4 to reinitiate the V2V function
 10. Charging will automatically stop if the source vehicle SOC goes below the user set SOC limit or at 30%. In that case follow the procedure from step 16.
 11. Also monitor the SOC of both vehicles frequently to check if sink vehicle is charged enough/ source vehicle SOC is reached the minimum required SOC level.
 12. To stop the V2V charging from source vehicle side, press the V2X switch of source vehicle to disable the 220V AC supply and follow from step 16 after 5sec.
 13. To stop the V2V charging from sink vehicle side, press its fascia switch and then ensure to press the V2X switch of source vehicle to stop the AC power supply. & follow step 14.
 14. After 5 sec delay press source vehicle fascia switch and then remove both the guns.
 15. In case V2V charging gets interrupted from source/sink vehicle side due to any fault, Press the Gun unlock fascia switch in both vehicle and completely remove the gun from both side and repeat from step 4. If the issue still remains, Press the Gun unlock fascia of both vehicle and completely remove the gun. After that keep the vehicles in Ignition OFF state for 120 seconds. Then repeat from Step 4.If the charging get interrupted again from vehicle side go to step 16 and contact nearby TAT service station.
 16. To remove the gun, Press Fascia switch of both vehicles. Close the V2V charging gun caps to ensure that it is not exposed to mud/metal particle etc.
-

CHARGING

DON'TS

1. Don't shift the gear
2. Don't crank source or sink vehicle during V2V charging.
3. Don't use un authorized V2V gun
4. Don't press the V2X switch of sink vehicle throughout the V2V function
5. Don't keep the V2V charging gun open at sink vehicle side while pressing the v2x switch in the source vehicle
6. Don't perform V2V charging in other vehicles which is not recommended by the TPDM (list to be published later) as source and sink vehicle
7. Don't keep the V2V gun caps open after the use to ensure it is not exposed to mud/metal particle etc.
8. Don't start V2V charging function if source Vehicle SOC is lesser than or equal to 30%.
9. Do not perform V2V charging during rain or in any situation where it might be exposed to water

10. Don't press V2X switch and fascia switch together to stop the function(keep minimum 5sec delay)
11. Don't keep both vehicle at far distance where the gun has to stretch maximum to connect between the vehicles.
12. Don't disengage the park brake in either of the vehicles during the charging.
13. Do not insert the V2L connector when vehicle is in Crank or EV ready condition.
14. Don't disassemble or remodel the V2V adaptor
15. Don't Drop the V2V gun to cause high impact and don't keep heavy objects over the gun

Vehicle Ignition ON state

1. Keep both sink (recipient) and source (donor) vehicle nearby and ensure maximum up to 3m distance between the charging inlets of the vehicles.
2. Turn ON the ignition of both sink (recipient)/source (donor) vehicle. Make sure to keep the vehicles in Ignition ON mode throughout the procedure

3. Engage the park-break OR EPB of both vehicles.
4. Remove the caps & connect the V2V gun to the source and sink vehicle. Check the labels on the V2V gun and make sure that the V2Vgun side labeled as "source" should connect to the source vehicle & the other end labeled as "sink" should connect to the sink vehicle.
5. Ensure V2V gun is connected to both vehicles and press the V2X switch of source vehicle to start the 220V AC power supply and to charge the sink vehicle. (TBC with VCU team-V2V status if V2X switch enabled in sink vehicle also)
6. Check telltale indication in instrument cluster of vehicles to ensure V2V charging is on.(check for the HMI)
7. Check for the telltale indication frequently when the V2V charging is in progress to ensure there is no interruption/fault.

8. Charging will automatically stop if the source vehicle SOC goes below 30%. In that case follow the procedure from step 14.
 9. Also monitor the SOC of both vehicles frequently to check if sink vehicle is charged enough/ source vehicle SOC is reached the minimum required SOC level.
 10. If SOC of source vehicle reaches the agreed Limit and to stop the V2V charging from source vehicle side, press the V2X switch of source vehicle to disable the 220V AC supply and follow from step 14 after 5sec
 11. If Sink vehicle is charged up to the agreed SOC level and to stop the V2V charging from sink vehicle side, press its fascia switch to stop charging and then ensure to press the V2X switch of source vehicle to stop the AC power supply. & follow step 12
 12. After 5 sec delay press source vehicle fascia switch and then remove both the guns & follow step 15.
 13. In case V2V charging gets interrupted from source/sink vehicle side due to any fault, Press the Gun unlock fascia switch in both vehicle and completely remove the gun from both side while keeping the vehicles in Ignition ON and repeat from step 1. If the issue still remains, Press the Gun unlock fascia switch in both vehicle and completely remove the gun from both side both. After that both vehicle should brought in to ignition OFF state. Keep the vehicles in Ignition OFF state for 30sec. Then repeat from Step 1. If the charging get interrupted again from vehicle side go to step 14 to 15 and contact service station.
 14. To remove the gun, Press Fascia switch of both vehicles. Close the V2V adaptor caps to ensure that it is not exposed to mud/metal particle etc.
 15. Turn off the Ignition in both vehicles
- DON'T'S**
1. Don't switch off the Ignition in source or sink vehicle during V2V charging
 2. Don't crank source or sink vehicle during V2V charging
 3. Don't use un-authorised V2V gun.
 4. Don't press the V2X switch of sink vehicle throughout the sink vehicle charging
 5. Don't keep the V2V charging gun open at sink vehicle side while pressing the v2x switch in the source vehicle after connecting the source side gun.
 6. Don't perform V2V charging in other vehicles which is not recommended by the TPPEM (list to be published later) as source and sink vehicle
 7. Don't keep the V2V gun caps open after the use to ensure it is not exposed to mud/metal particle etc.
 8. Don't start V2V charging function if source Vehicle SOC is lesser than or equal to 30%.
-

CHARGING

9. Do not perform V2V charging during rain or in any situation where it might be exposed to water
10. Don't press V2X switch and fascia switch together to stop the function(keep minimum 5sec delay)
11. Don't keep both vehicle at far distance where the gun has to stretch maximum to connect between the vehicles.
12. Don't disengage the park brake in either of the vehicles during the charging.
13. Don't insert the V2L connector when vehicle is in Crank or EV ready condition.

Vehicle to Load Charging (V2L)



Vehicle Ignition OFF state

1. User can decide the discharge SOC limit of the vehicle and can preset the SOC limit in infotainment before starting the V2L function.
 - Since infotainment system won't be awake in Ignition OFF state, Limit can be set only in ignition ON or Crank ON condition in the previous cycle.
 - Discharge SOC Limit cannot be changed during the V2L function.
2. Make sure to keep the vehicle and the V2L adaptor in dry environment/in shade
3. If the vehicle is in OFF state, Open/close the door or If vehicle is in locked state Press RKE unlock button and open the door to wake up the vehicle control unit. Once wakes up, Vehicle control unit will remains in wakeup state for 120sec
4. Remove the V2L adaptor caps & connect the V2L adaptor gun to the source vehicle within in 120sec of step 3.
5. Make sure park-brake/EPB is engaged.
6. If user couldn't connect the V2L gun within 120sec of step 3, then remove the Gun completely and repeat from step 3
7. Connect external load to the V2L adaptor 3pin socket. Make sure that Electrical loads are healthy/in good
 - In case if no limit is set by the user, 30% SOC will be consider as default discharge SOC limit

- condition and ensure the relevant cables and plugs of loads are connected properly.
- When using multiple loads make sure Total power consumption of the loads should be lesser than 3.3Kw or total current demand of loads should be lesser than 16A.
 - If the electric appliances demand exceed the maximum power and current capacity that the vehicle can provide, V2L function will stop from vehicle side.
 - It is recommended to use home appliances with Power factor greater than 0.85.
 - If multiple loads are connected on extension box, it is recommended to use extension box with MCB (16A) & with M Type plug and socket. The MCB switch needs to be in switched off/ turned off condition.
8. Press V2X switch within 120sec of step 4 to start 220V AC power supply from vehicle. If user couldn't press V2X switch within 120sec of step 3. Remove the Gun completely and repeat from step 3 to initiate the V2L function.
 9. Ensure safety precaution against the live 220VAC voltage in the V2L adaptor.
 10. Turn on the loads.
 11. Check telltale indication in instrument cluster to ensure V2L discharging is initiated/in progress
 12. Check for the telltale indication frequently when the V2L discharge function is in progress to ensure there is no interruption/fault.
 13. V2L function will stop if there is no energy dissipation has happened/if there is no load is connected for 100secs from successful step 8. In this case, remove the gun completely and start from step 3 to reinitiate the V2L discharge function.
 14. To stop the V2L discharge function, First switch off the external loads and then press V2X switch second time to disable the 220V AC power supply and Go to step 17.
 15. V2L function will automatically stops if the source vehicle SOC goes below the user set value or at the default value of 30%. In that case go to step 17.
 16. In case V2L function gets interrupted from vehicle side due to any fault, Press the Gun unlock fascia switch in vehicle and completely remove the gun repeat from step 3.
 - If the issue still remains, Press the Gun unlock fascia and completely remove the gun. Keep the vehicles in Ignition OFF state for 120sec. Then repeat from Step 3.
 - If the charging get interrupted again from vehicle side go to step 17 and vehicle along with the V2L adaptor need to be taken to nearby TATA service station
 17. Switch off and remove the Connected Loads then Press Fascia switch and remove the V2L adaptor. (Close the

CHARGING

V2L adaptor caps to ensure it is not exposed to mud/metal particle etc).

DON'TS

1. Don't crank the vehicle during V2L charging
2. Don't use unauthorized V2L adaptor
3. Don't use High power home appliances like air conditioner, dryer having power consumption more than 3.3Kw and current requirement more than 16A
4. Don't hang the appliances on the V2L adaptor
5. Don't use appliances or extension box which is not having national safety certificate. Refer each device manual to know the usage and precautions to be taken.
6. Don't use any unhealthy or improper electrical connection/ apparatus for V2L discharge function like loads with insulation failure, short circuit, improper 3pin/2pin plug, open cables without plug)
7. Don't allow the appliances/extension box cables to twist or overlapped.
8. Don't use the appliances if its cable sheath is damaged.
9. Don't use the electric devices which require continues power supply like medical equipment. since AC power supply may get interrupt based on the vehicle condition
10. Don't use the load which required high power at the starting/initial operation
11. Don't use the loads which is sensitive to Inverter type AC supply
12. Don't touch V2L adaptor socket side during V2L function
13. Don't keep the V2L adaptor caps open after the use to ensure it is not exposed to mud/metal particle etc.
14. Don't start V2L charging function if Vehicle SoC is lesser than 30%.
15. Don't perform V2L charging during rain or in any situation where it might be exposed to water
16. Don't press V2X switch and fascia switch together to stop the function.(keep minimum 5sec delay)
17. Don't disengage the park brake during V2L charging
18. Don't mishandle the V2L adaptor.
19. Do not insert the V2L connector when vehicle is in Crank or EV ready condition.
20. Don't shift the gear
21. Don't disassemble or remodel the V2L adaptor
22. Don't Drop the V2L adaptor to cause high impact and don't keep heavy objects over the adaptor.

Vehicle Ignition ON state

1. Turn ON the source vehicle ignition. Make sure to keep the vehicle in Ignition ON mode throughout the procedure.
2. Make sure to engage the park-brake/EPB.
3. Make sure to keep the vehicle and the V2L adaptor in dry environment/in shade.

4. Remove the caps & connect the V2L adaptor gun to the source vehicle.
5. Connect external load to the V2L adaptor 3pin socket.
 - Make sure that Electrical loads to be used for V2L charging are healthy/in good condition and ensure the relevant cables and plugs of loads are connected properly.
 - Total power consumption of the loads used should be lesser than 3.3Kw and it is recommended to use the loads with Power factor greater than 0.85
 - In case of multiple loads, it is recommended to use extension box with MCB (16A) & with M Type plug and socket.
6. Press the V2X switch to start the 220V AC power supply. (check for the HMI).
7. Ensure safety precaution against the live 220VAC voltage in the V2L adaptor.
8. Turn on the loads.
9. Check tell-tale indication in instrument cluster to ensure discharging is initiated/in progress.(check for the HMI)
10. Check for the tell-tale indication frequently when the V2L is in progress to ensure there is no interruption/fault.
11. To stop the V2L charging, first switch off the External loads and then Press V2X switch in the vehicle to stop the AC power supply and Go to step 14 (check for the HMI)
12. V2L charging function will automatically stops if the source vehicle SOC goes below 30% (Configurable). In that case go to step 14.(check for the HMI & tell-tale indication on instrument cluster)
13. In case V2L charging gets interrupted from vehicle side due to any fault, , Press the Gun unlock fascia switch in vehicle and completely remove the gun while keeping the vehicles in Ignition ON and repeat from step 1.
- If the issue still remains, Press the Gun unlock fascia and completely remove the gun. After that vehicle should brought in to ignition OFF state. Keep the vehicles in Ignition OFF state for 30sec. Then repeat from Step 1.
- If the charging get interrupted again from vehicle side go to step 14 to 15 and vehicle along with the V2L adaptor need to be taken to service station.
14. Switch off the Connected Loads then Press Fascia switch and remove the V2L adaptor and connected loads. (Close the V2L adaptor caps to ensure it is not exposed to mud/metal particle etc.)
15. Turn OFF the vehicle ignition.

CHARGING

DON'T'S

1. Don't switch off the vehicle Ignition during V2L charging
2. Don't crank the vehicle during V2L charging
3. Don't use unauthorized V2L adaptor
4. Don't use any unhealthy or improper electrical connection/ apparatus for V2L charging. (e.g.: loads having power consumption>3.3Kw, insulation failure, short circuit, improper 3pin/2pin plug, open cables without plug).
5. Don't keep the V2L adaptor caps open after the use to ensure it is not exposed to mud/metal particle etc.
6. Don't start V2L charging function if Vehicle SOC is lesser than 30%.
7. Don't perform V2L charging during rain or in any situation where it might be exposed to water.
8. Don't press V2X switch and fascia switch together to stop the function.(keep minimum 5sec delay).
9. Don't disengage the park brake during V2L charging
10. Don't mishandle the V2L adaptor.
11. Do not insert the V2L connector when vehicle is in Crank or EV ready condition.

KEYS

A key is an electronic access and authorization system available as a standard feature with your vehicle.

Unlocking Principle

The transponder in the ignition key carries a Unique Identification Code (UID). The vehicle unlocks when the code on the key matches with the code on the Battery Management System (BMS). In case of PEPS variant, Immobilizer function is provided by Aptiv BCM and PEPS ECU.

Loss of Keys

If one of the keys is lost, Contact the TATA MOTORS EV Authorised Service Centre immediately.

- Do not leave the key in high temperature areas. The transponder in it will behave abnormally when re-used.

WARNING

- Do not turn 'ON' ignition switch by using key with any type of metal wound around its grip or in contact with it. This may be detected as abnormal condition by immobilizer and prevent vehicle from starting.

OPENING AND CLOSING

Smart Key (PEPS) (if equipped)

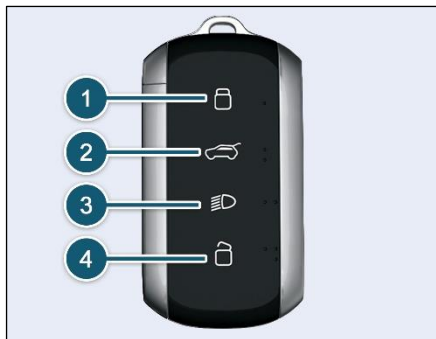

Keep the smart key with user to perform the passive access. It is used for locking, unlocking and starting the vehicle.

1. Locking all doors
2. Tail Gate unlatch /
Power Operated Tailgate Open and Close (if equipped)
3. Short press for Approach Light
Long press Approach lamp button for SoC state
4. Unlocking all doors

1. Locking All Doors

Press the lock button once (1) to lock all the doors of the vehicle. Successful lock will be indicated by two flashes of turn signal indicators. If lock button is pressed on the key with the any door open, locking-unlocking takes place with audible warning indicators do not flash.

2. Tail Gate unlatch

Press the tail gate opening button once (2) to unlock the tailgate with in authentication range of Smart key i.e. 1 to 1.5 meters

2. Power operated Tailgate Open and Close (if equipped)

To open and close tailgate press the button. If button is long pressed for 3 seconds then the tailgate will open or close.

3. Short press for Approach Light

This feature helps to find and reach the parked vehicle. When you press approach light button (3) once, low beam, roof lamp and position lamps will turn ON'. This feature helps to find and reach

the parked vehicle or to reach home in dark/ cloudy condition after parking. To switch 'OFF' the approach lights, press and release the same button or it automatically turns 'OFF' after approx. 30 sec.

Long press Approach lamp button for SoC state

Long press the approach light button (3) more than 3 second, Vehicle display the Battery SoC on CPL for few sec.

4. Unlocking All Doors

Press the unlock button once (4) to unlock all the doors. Successful unlock will be indicated by one flashes of turn signal indicators.

NOTE

If smart key battery is low/drained or vehicle battery is low/drained, user can unlock and enter into vehicle by using mechanical key blade, which is present inside the smart key.

Emergency Key Blade IN / OUT



Press the knob (1) to release the key. Pull the key blade (2) out.

Smart Key Features (if equipped)

Vehicle Seek

In vehicle locked condition, if lock button on smart key is pressed, the turn indicators of vehicle flashes 4 times.

Auto Locking (Drive away locking)

All the vehicle doors can be locked by automatically, after vehicle speed cross the more than 13 kmph.

This can happen if any one of the vehicle door not locked properly during the running state / condition of the vehicle.

If UID vehicle unlock button pressed and no any action with respect to vehicle doors transition or UID buttons press within 30 sec, then after the vehicle shall automatically locked.

Unlocking of Doors

(Auto unlock): During the vehicle Ready or IGN ON state. If vehicle doors are locked by automatically or user locks the vehicle internally (through vehicle lock switch) after that user turn off the vehicle (vehicle power mode is OFF), in case all

vehicle doors shall be automatically unlocked.

Auto Unlock

In PEPS variants, door will get unlocked when ignition is OFF by pressing Start Stop switch.

Anti-grab / Anti-scan Coding

The remote control set of this security system is protected against the use of devices called 'scanners' and 'grabbers' which can record and reproduce some types of remote codes.

OPENING AND CLOSING

Important Tips

- Don't operate Unlock button of remote in the vicinity of your vehicle, as it could lead to an unintentional unlocking your vehicle.
- For battery, replacement procedure refer 'MAINTENANCE' section.
- Do not remove the battery connection of the vehicle while the vehicle has been locked by remote.

Smart Key Precautions

1. If smart key is close to radio transmitter such as radio station or an airport which can interfere with normal operation of the transmitter.
2. If smart key is near a mobile two way radio system or a cellular phone, then it will not work properly.
3. If another vehicle's smart key is being operated close to your vehicle, signal will fluctuate.

NOTE

Keep smart key away from electromagnetic materials that blocks electromagnetic waves to the key surface.

NOTE

In case any button of the key is accidentally pressed for more than 20 seconds, the remote stops functioning till the time the button is pressed. The LED on the Remote also stops glowing. The function of the remote gets reinstated immediately when the user

stops pressing the push button of remote.

Force Panic ON Operation

When vehicle is in OFF condition, if we press lock button and un-lock button simultaneously, Force panic operation gets activated. In this case, turn indicators of vehicle start flashing and horn will blow automatically.

Force Panic OFF Operation.

Pressing lock / unlock button of smart key instead of pressing any button of smart key.

DOORS

Door Locking / Unlocking Using Door Handle Switch (DHS)

To lock/unlock all the doors without operating smart key button/ key blade.

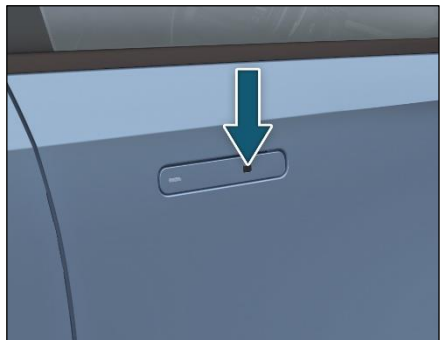

Press the door handle switch (DHS) provided on the driver door to lock/un-lock all the four doors except Tail gate.

*i*NOTE

- *Authentication range for smart key shall be 1 to 1.5 meters from outside the respective door or tail gate.*

- *Passive entry only works during ignition off.*

*i*NOTE

Door handle will return to the original position automatically when the handle is released after opening the door

Horn Honking When Door Locking Using Door Handle Switch (DHS)

If vehicle is in unlock condition and Smart key is present inside the vehicle. If you try to press the door handle switch then vehicle horn honking gets activated for 9 sec.

Emergency Operating of Door through flush

- Unlock the Vehicle thru PEPS Switch or through remote. Once the Vehicle is Unlocked, the Door can be Unlatched

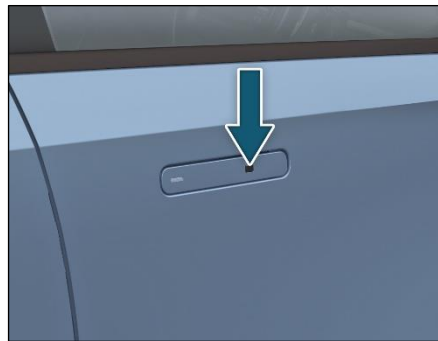

- Push the handle slightly at the area on the Gripper as shown in the image.

OPENING AND CLOSING



- Pull the Handle Gripper firmly towards Outward.

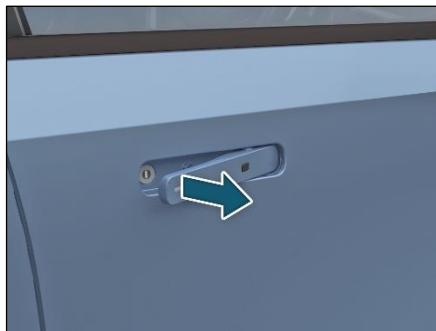

*i*NOTE

After opening the door, do not forget to push the gripper back to home position.

- Insert it into the keyhole.

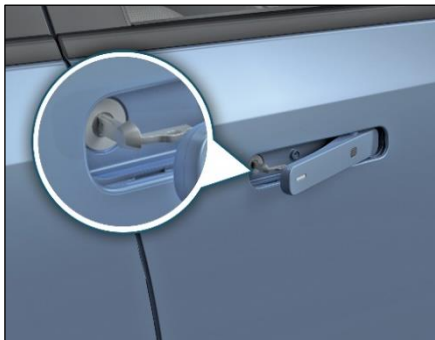

*i*NOTE

The driver door can be manually locked/unlocked from outside by using conventional key.

- Turn the key anti-clockwise to lock or clockwise to unlock the door.



*i*NOTE

Conventional locking is on driver door side only, No key lock set on co-driver door.

- For unlocking insert the key and rotate it in clockwise gently (don't apply abusive load).
- Take out the key to return the handle to nominal position and pull back the handle to open the door.

OPENING AND CLOSING

Do's and Don'ts

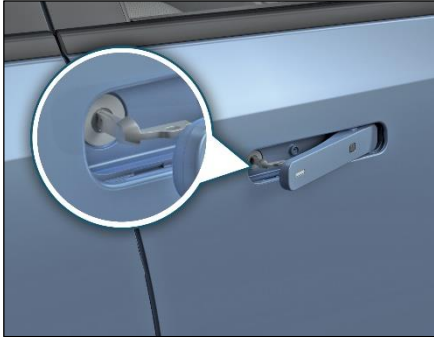

Correct direction of key



Incorrect direction of key

Doors Locking / Unlocking From Inside



All doors can be opened from inside by pressing knob on driver door and independently on other doors

iNOTE

There is a single pull override feature on driver door. All door can be unlocked by inner handle without operating lock knob of inner handle.

OPENING AND CLOSING

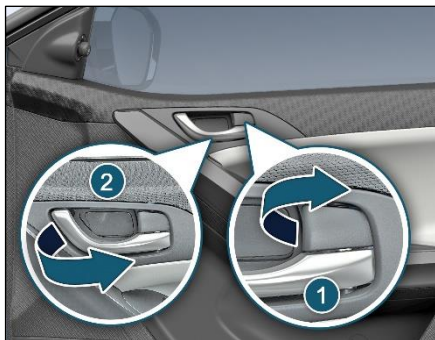

Pull the door opening knob (1) and then opening lever (2).

Rear Door Opening

Door opening handle is provided on the side of the window.

To open the door, press the lever provided inside the handle and pull.

WINDOWS

Power Windows



Window glasses 1-2-3-4 on all four doors can be operated by switches provided on the main control panel located on the driver's arm rest. They work only when the key is in the 'IGN ON' position.

iNOTE

Power windows can be operated for 30 seconds in 'IGN OFF' and 'KEY OUT' positions, provided the doors are closed.

Express UP

Window glass can be closed by single pull of the switch. Express up feature is provided for the driver's door only.

Anti-Pinch Function (if equipped)



The Anti-pinch function will stop window upward movement if any obstruction or resistance detected.

Thus, it gives full and reliable protection for hand, neck etc. Anti-pinch function is provided for driver door only.

Anti-pinch Inhibition

After 3 successive anti-pinch reversals with less than 5 seconds delay between each reversal in switch operated mode, Anti-pinch function shall be de-activated until complete closed condition is detected.

Express Down

Window glass can be opened by a single long press of the switch (1). Express down feature is provided for the driver's door only.

OPENING AND CLOSING

Inhibit Switch

When switch (5) is pressed, amber light turns 'OFF'. The individual switches provided on other doors are not functional. It can be only operated by driver side switch. As the switch is depressed amber light turns ON and individual switches became not functional. It can be only operated by driver side switch.

WARNING

- If children operate the windows they could get trapped, particularly if they are left unsupervised. There is also a risk of injury.
- Activate the window inhibit feature when children are travelling. When leaving the vehicle, always take the key with you and lock the vehicle. Never leave children unsupervised in the vehicle.

Individual Switches

Individual switch has been provided on all doors.



To close the glass pull the switch in upward direction.

To open the glass press the switch in downward direction.

Lateral Sunshade Curtain (if equipped)

WARNING

- The purpose of sunshade is to prevent discomfort caused by sunlight coming directly into the vehicle.
- Sunshade may get damaged due to head rested on it/contact with any pointed item like ornaments, nails etc/pulling of cloth/fabric abruptly.
- Do not open door glass with sunshade ON while vehicle is in motion this may damage the sunshade.

BONNET AND CHARGING FLAP

Bonnet Opening

1. Make sure to engage the parking brake for your safety.
2. Pull the bonnet release lever. It will pop up slightly.



3. Raise the bonnet slightly and with your finger slide the secondary lock lever.

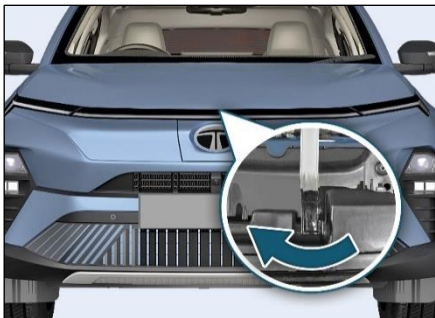

iNOTE

Make sure that the wiper arms are not raised before you lift up the bonnet to avoid damaging the wiper arms and the bonnet.

4. Lift the bonnet up and pull the stay rod from its clip and insert the free end into the slot provided on frame.

⚠CAUTION

Insert the stay rod into the hole securely. If the rod drops off, your body may be caught below the bonnet.

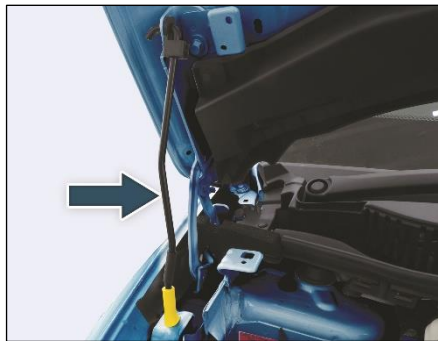

Bonnet Closing

1. To close, hold the bonnet by one hand, disengage the stay rod and clamp it back properly.
2. Lower the bonnet close to the bumper, then let it drop down.

⚠WARNING

Ensure that the bonnet is properly locked before driving or it can fly up unexpectedly during driving.

OPENING AND CLOSING

Opening Charging Flap



1. Make sure to engage the parking brake for your safety.
2. To open the charging flap, press the switch located on fascia switch. The cover will fully open.



Closing charging flap



1. Press switch on fascia switch to close charging flap.

iNOTE

After pressing switch for closing, it is active only for 9 minutes considering 2 times Anti-pinch operation after opening the charging flap

2. Start the vehicle to close the charging flap automatically.
3. Charging flap will Auto close after 3 min of inactivity or perform anti-pinch operation if any obstacle comes while operating.
4. In 'Ignition OFF' vehicle condition, if charging gun is inserted, the charging flap will try to Auto close 2 times after every 3 minutes by performing anti-pinch operation & charging flap will remain in open condition.
5. In 'Ignition OFF' vehicle condition, post charging after removal of gun, to Close the charging flap press switch on Fascia switch or start the vehicle to close the charging flap automatically.



6. In 'Ignition ON' vehicle condition with fast charging option, post charging after gun removal, to Close the charging flap press switch on Fascia switch or start the vehicle to close charging flap automatically.
7. In 'Ignition ON' vehicle condition with slow Charging option, post charging after gun removal, charging flap will Auto close after 3 minutes or use push to close option to close the charging flap.
8. If auto close / push to close option not worked, kindly close the charging flap via pressing the switch on Fascia switch or start the vehicle to close the charging flap automatically.

NOTE

- *Charging flap is not used or operated, it will automatically turns 'OFF' after 3 minutes.*
- *Manual closing of the charging flap is strictly prohibited & can damage the product.*

OPENING AND CLOSING

MECHANICALLY OPERATED TAILGATE

Option	Image	Operation
Option I Using Smart Key	 A black smart key fob is shown vertically. A blue arrow points to the tailgate icon, which is a rectangle with a smaller rectangle inside, located between the lock and unlock icons.	Press a tail gate opening button on remote and release. To close, slam the tail gate to latch and it gets locked. Note: vehicle to be in authentication range.
Option II Through Fascia switch	 A close-up view of the vehicle's interior fascia switch. A blue arrow points to a button with a tailgate icon, located in the center of the switch panel.	To open the tail gate, press the switch located on fascia switch.
Option III Using DHS on tail gate	 A rear view of a blue vehicle. A circular callout with a blue arrow points to the DHS (Direct Hide System) button on the tailgate, which is a small rectangular button with a tailgate icon.	DHS on tail gate is pressed with valid key in the authentication range, the tail gate gets unlatched. To close, slam the tail gate to latch then it gets locked. If the valid smart key is left inside the trunk then tail gate gets unlocked.

POWER OPERATED TAILGATE (if equipped)

The Power Operated Tailgate has capability to automatically open and close when the trigger is provided by the user. It consist of a motor which drives the tailgate to open or close. A hazard flashes and buzzer indicate the customer while opening and closing of power tailgate.

NOTE

Before opening the tailgate, make sure that the vehicle is stationery, accessory delay, awake mode, ignition ON and the parking brake is engaged.

To open, close or stop the tailgate automatically one of the triggers from the following will be used

1. PEPS Key
2. Tailgate Fascia Switch
3. Tail gate Kick Sensor [hands free access]
4. Tailgate Closure Switch (Inside Tailgate, Close Only)

5. Tailgate PEPS Switch (External Tailgate open switch) on Tailgate trim (Door).

1. PEPS Key

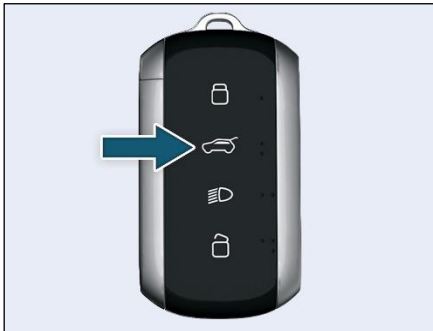

1. To open and close tailgate press the button. If button is long pressed for 3 seconds then the tailgate will open or close.
2. To stop the tailgate while opening and closing is in progress, short press Tailgate button. Tailgate will automatically stop and will work only when PEPS key is near to vehicle vicinity and this feature is enabled from infotainment.

2. Tailgate Fascia Switch



1. To open and close tailgate, press the tailgate fascia switch.
2. To stop tailgate, press fascia switch while tailgate is closing or opening.

OPENING AND CLOSING

3. Tailgate Kick Sensor (Hands Free Access)



1. To open and close tailgate automatically by kicking the feet near to rear bumper area as shown in picture.
2. To stop the tailgate while opening and closing is in progress, kick your feet near to rear bumper area.
3. Automatic tailgate opening, closing or stopping will work only when PEPS key is near to tailgate vicinity and gesture feature is enabled from infotainment.

i NOTE

For lock and unlock state PEPS key should be in vehicle tailgate vicinity.

Things to follow using Tailgate kick sensor (Hands Free Access)

1. While kicking your feet, do not hit or touch the bumper inside or outside.
2. Swipe at the center of the bumper, aligned with the TATA logo and nearby area (proximity calibrated to 1.5 feet).
3. A quick leg kick or a quick kick gesture will work; all other forms of gesture will not work. For example, continuous swiping, slow swiping close to the bumper, kicking at the left or right bumper, or at the vehicle edge.
4. After applying kick move back to a sufficient distance so that not to cause any obstruction to tailgate opening.
5. Do not kick or keep leg near to HFA area for long time. It will not be considered a valid kick, and tailgate will not open or close with such an operation.
6. While cleaning the bumper area with cloth, sponge or a high pressure water pump, if PEPS key is within the tailgate area or with user then it be considered as valid kick to open or close the tailgate. Therefore, user are advised not to keep the PEPS key within the tailgate vicinity while cleaning.
7. If the spare wheel (if equipped) is removed from the vehicle, the kick sensor may not sense for tailgate operation. Therefore, it is advised to always keep the spare wheel in its position for tailgate open/close operation with kick (HFA).
8. In the rainy season if the mud is accumulated at HFA area, then HFA sensor's working performance may degrade. Therefore, users are advised to keep kick sensor area clean for better performance.

4. Tailgate Closure Switch (inside Tailgate)



1. Inside tailgate switch can be used to close, stop tailgate and to store user intended maximum tailgate height when it's open.
2. To close or stop tailgate, press inside tailgate closing switch.

Height Setting through Tailgate Closure Switch:

User can limit tailgate opening by setting the customized tailgate height. Below is the procedure.

1. Open the Tailgate to the position required as the maximum height. Press any Tailgate control to stop movement at the required position. The final position can be achieved manually, if required.
2. Make sure the Tailgate is stationary for at least 3 seconds.
3. Press and hold the Tailgate close button for 5 seconds to set the maximum opening height. You will hear a long beep from POT ECU to confirm height set.
4. After step 3 is executed, if Tailgate initiates closing operation, then height will not be set.
5. If the Height is not set successfully user will hear 3 beep sound from buzzer
6. Close the Tailgate, then open again to check that it opens to the set height.

Buzzer Indication for Opening/closing/fully Closed

1. Buzzer sound is provided to indicate the user about current tailgate operation when buzzer setting from infotainment is enabled.
2. When tailgate opening initiated, buzzer and hazard flashes will drive twice.
3. When tailgate closing initiated, buzzer and hazard flashes will drive twice.
4. When tailgate is fully closed, buzzer and hazard flashes will drive once.

Obstacle Detection and Anti-pinch

1. It is advisable to check if there is obstruction in the tailgate travel while closing or opening.
2. If a tailgate close operation is initiated and an obstacle is detected during ongoing movement, then the current tailgate close operation will be aborted and a rewind tailgate open operation will start.

OPENING AND CLOSING

- If tailgate open operation is initiated and an obstacle is detected during on-going movement, then the current tailgate open operation will be aborted, and tailgate will stop.
- In manual operation obstacle detection will not work.
- Hardware based anti-pinch is not available, however software-based obstacle/anti-pinch is available.
- If an obstacle is detected close to the edge of vehicle, then due to time and force required for obstacle detection mechanism, that obstacle may not get detected and will create pinch to that obstacle. So, it is always advised to check if there is any obstruction between closing tailgate and vehicle closing edge to avoid any injury/ damage.

Tailgate Infotainment Setting



- Enable/Disable Gesture Feature
- Enable/Disable PEPS Feature
- Enable /Disable Buzzer Feature
- Tailgate Height Setting

WARNING

- Obstructing the tailgate operation intentionally may cause serious injury to the person or damage to vehicle though it is equipped with obstacle detection feature.
- Power strut equipped tailgate shall not be operated manually. However in the exceptional case like battery discharge it has to be operated gently. While operating manually (opening/closing) recommended to hold tailgate at the center portion.

- Do not grab or hold Power struts or try to disassemble them.
- Don't drive the vehicle with Tailgate open, doing so will allow dust to enter the vehicle cabin, will obstruct rear approaching vehicles visibility and also may damage power struts.
- Don't apply forces on power struts (e.g. pushing vehicles, tightening straps or applying other fasteners). Doing so will damage the struts and may lead to injuries.
- Don't allow anyone to occupy luggage compartment as it is highly dangerous location in case of crash event.
- Don't modify or repair any part of power tailgate. Reach out to the nearest TATA MOTORS Authorized EV service centre in case of any functional failures.
- Never leave children or animals unattended in your vehicle. Children or animals might operate the power tailgate that could result in injury to

themselves or others or damage to the vehicle.

- Make sure objects in the rear cargo area do not come out when opening the tailgate on the slope way. It may cause serious injury.

NOTE

- *Make sure no object, fingers or person etc. is obstructing tail gate operation while opening and closing, if so it can get trapped with damage or serious injury.*
- *Driving vehicle with tail gate open or partially open is not recommended.*
- *Accessories other than OEM approved, not to be fitted on tailgate. It may result into improper operation of power tailgate or damage the power strut.*
- *Multiple operation of power tailgate can drain the battery, if ignition is OFF.*

- *Do not leave power tailgate open for a long period of time. This may drain the battery.*
- *Power tailgate can be operated when the vehicle is not running. However the power operation consumes large amounts of vehicle electric power. To prevent the battery from being discharged, do not operate them excessively.*
- *When jacking up the vehicle to change a tyre or repair the vehicle, do not operate the power tailgate. This could cause power tailgate to operate improperly.*
- *The outside power tailgate switch may not function properly in extreme cold or wet climatic conditions. In such cases it is operate through remote key or from center console switch.*
- *In cold and wet climates, door lock and door mechanisms may not work properly due to freezing conditions.*

- *When power tailgate is opened manually (without electrical operation), more effort will be required to open and close compared to the non-powered tailgate.*
- *Play protection feature is available to prevent overheating. This feature prevents the power tailgate to operate and allow the power struts to cool down. The power tailgate system can be operated again after 1-2 minute time period.*
- *It is recommended to wait until the power tailgate fully closed before starting the vehicle. The power tailgate may not close fully if the vehicle is started during automatic closing.*

OPENING AND CLOSING

5. Tailgate PEPS Switch (External Tailgate open switch) on Tailgate trim (Door).

User press the tailgate open switch (which is located externally on tailgate door) to access the vehicle trunk, then after 2 sec delay, tailgate start auto open / close based on the vehicle lock / unlock state and with valid smart key within vicinity area.

If any interrupt (Trigger) given during the tailgate auto operation, then it will stop the operation. It will resume the operation after next interrupt (trigger).

DIGITAL DISPLAY (7" Inch) (If equipped)

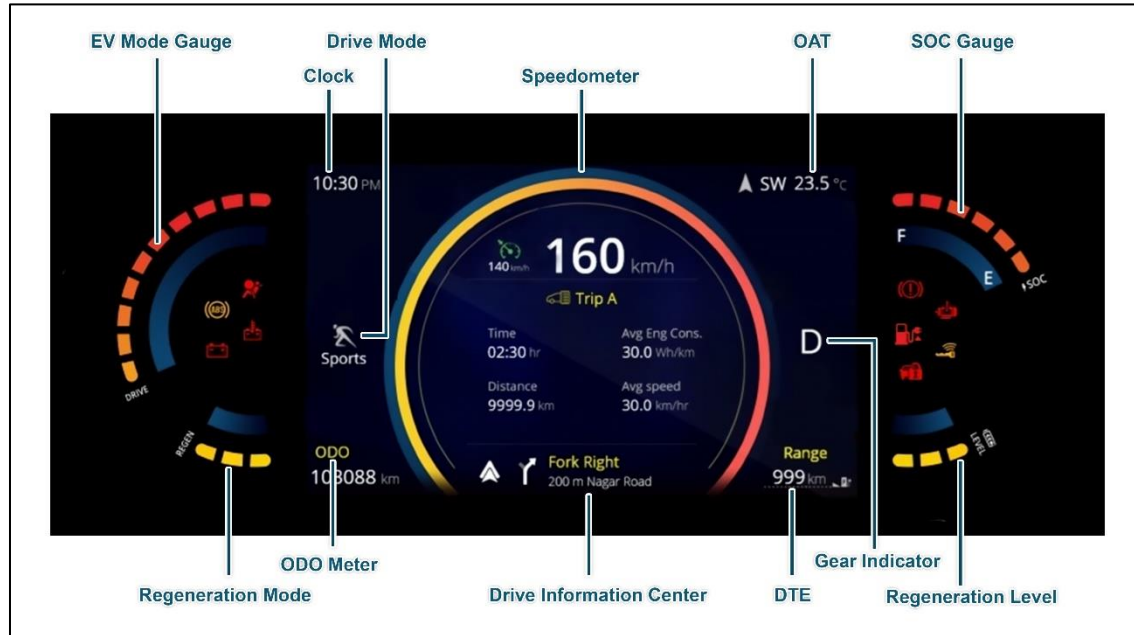

NOTE: All indicators and values are for illustration purpose only.

INSTRUMENT CLUSTER



Gauge Name	Information	Note/Warning
Speedometer	The Speedometer Indicates the actual vehicle speed in km/h	<ul style="list-style-type: none"> At every key IN and Ignition ON, the speedometer Bar moves to MAX and return to '0' position. This is welcome strategy and self-check feature In vehicle running condition if the Speedometer is not showing the Vehicle speed, then take the vehicle to TATA MOTORS EV Authorised service center.
Odometer	Odometer Indicates distance travelled by vehicle.	<ul style="list-style-type: none"> The odometer reading does not return to 0 when maximum value is reached, the display will freeze to maximum value.
SoC Gauge	SoC (State of Charge) gauge indicates the battery state of charge to user in percentage	<ul style="list-style-type: none"> When battery SoC goes below 5%, first Bar in gauge will start blinking. Do not drive the vehicle with low SoC.
EV mode Gauge	<ul style="list-style-type: none"> This function provides instantaneous power consumption mode of vehicle during driving and displayed in the instrument cluster. 	When all functional modes are activated, then take the vehicle to TATA MOTORS EV Authorized service center.

Gauge Name	Information	Note/Warning
	<ul style="list-style-type: none"> • During the IGN ON of the vehicle, EV mode gauge will starts sweep from REGEN mode to DRIVE mode and then back to the REGEN mode to indicate the welcome strategy behavior. • For DRIVE mode, LED BARs will be ON as per the power consume 	
Distance To Empty (DTE)	<ul style="list-style-type: none"> • Range indicates approximate distance (km) that the vehicle can travel with current battery charge. • Range shall be indicated both in IGN ON & IGN OFF conditions. • In IGN OFF when charger is connected and charging is happening then Range value will display as long as screen is activated in the cluster. • 'RECHARGE' shall be displayed which indicates that it's the time to take your vehicle to the nearest charging station and the distance that a vehicle can travel with current charge is 20 Kms. 	<ul style="list-style-type: none"> • If Range is displayed as '—', take vehicle to TATA MOTORS EV Authorised Service Centre. • The Range values may vary significantly based on driving conditions, driving habits, and condition of the vehicle. • The Range value is an estimate of the available driving distance. • Change of distance unit is not applicable.



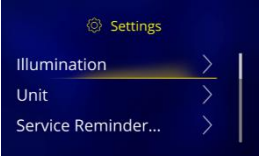

INSTRUMENT CLUSTER



Gauge Name	Information	Note/Warning
Regeneration Level Selection	<ul style="list-style-type: none">This function provides Regeneration Level settings to user from Minimum to Maximum in steps of Level 0, Level 1, Level 2 and Level 3 of vehicle during driving and displayed in the instrument cluster	<ul style="list-style-type: none">The “Maximum” Regen Level setting provides the maximum amount of regenerative braking power & it recaptures the most energy and reduces wear & tear on the brakes.The “Minimum” Regen Level setting incorporates a reduced regenerative braking force that recaptures less energy but allows the vehicle to coast further than in the “Maximum” Regen Level.

DRIVER INFORMATION SYSTEM (DIS)



Driver Information	System Image	Description
SERVICE RE-MINDER		<p>User can select Service Reminder Screen using controls on steering wheel to navigate & by pressing Set Button in Settings Screen. Service reminder is a feature to alert the user for service action. When distance since last service meet the maximum distance criteria, a service screen will get activated for the user to indicate the service of the vehicle has to be done along with the tell tale indication. User can reset the Service Reminder Symbol by right/left & SET buttons on the steering wheel.</p>
OUTSIDE AMBIENT TEMPERATURE		<p>This displays outside ambient temperature in units of °C with the resolution of 1°C.</p> <p>Note: If display shows '- -', take your car to TATA MOTORS EV Authorized Service Centre.</p>
DOOR AJAR		<p>This feature monitors the Door Input and warns Driver if any Door or trunk lid is open</p> <p>Note: If any other door is open roof lamp will be 'ON' provided that roof lamp switch is in ON position.</p>

INSTRUMENT CLUSTER

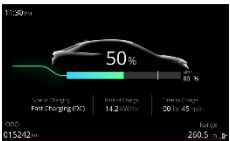

Driver Information	System Image	Description
GEAR INDICATION		<p>Current gear engaged by the transmission shall be displayed on DIS.</p> <p>Note: If is displayed, it means 'Fault' condition. In such case, take vehicle to authorized TATA MOTORS EV Authorized service Centre.</p>
SERVICE REMINDER RESET		<p>User can select Service Reminder Screen by Scroll down & pressing Set Button in Setting Screen.</p> <p>User can reset (Yes / Cancel) the Service Reminder by UP / DOWN & SET Buttons.</p> <p>Note: In the Setting menu if there is no user input for 10 secs the previous screen shall be displayed.</p>
ENERGY FLOW ANIMATION AND ENERGY HISTOGRAM		<p>This indicate the energy flow from the battery to the front wheels via electric motor or the flow to battery from high voltage components in case of regenerative braking.</p> <p>Animation = Forward (Battery to Motor)</p>
		<p>This indicate the energy flow from the battery to the front wheels via electric motor or the flow to battery from high voltage components in case of regenerative braking.</p> <p>Animation = Reverse (Motor to Battery)</p>

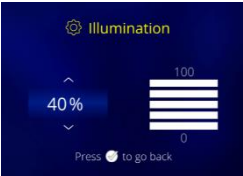
Driver Information	System Image	Description
CHARGER NOT CONNECTED		<p>This function displays the Charger Connected status information. When charger is not connected.</p>
		<p>When Charger is connected and not charging in IGN ON.</p>
CHARGER CONNECTED		<p>When Charger is connected and charging ON in IGN ON.</p>
		<p>When charger is connected in IGN OFF.</p>

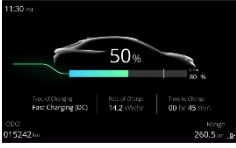

INSTRUMENT CLUSTER

Driver Information	System Image	Description
SETTINGS SCREEN		<p>User can enter into setting screen by pressing select button while being in setting screen.</p> <p>Screen get displayed into setting screen</p>
ILLUMINATION SETTING		<p>User can select Illumination Setting by Scroll down & pressing Set Button in Setting Screen provided park lamp ON.</p> <p>The Illumination level after ramping up will ramp down to user setting within 2s of completing welcome sweep.</p> <p>User can increase the illumination from (20% to 100%) in 5 steps by using UP & SET Button. User can decrease the illumination from (100% to 20%) in 5 steps by using DOWN & SET Button.</p>
CLOCK		<p>Instrument Cluster equipped with digital clock which indicates current time in 12 / 24 hours mode.</p>
PRESS BRAKE PEDAL		<p>Before you start the vehicle, press the brake pedal and then press the start/stop button.</p>

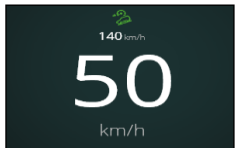

INSTRUMENT CLUSTER

Driver Information	System Image	Description
VEHICLE STATUS READY		This function displays that vehicle is in Run mode.
TIME TO CHARGE		<p>This function indicates the time required to charge the battery to 100%. Time remaining to charge displayed on cluster in Hrs & Mins.</p> <p>Note: <i>Time to charge screen comes only in charging ON and IGN OFF condition for 60 Sec for every interrupt.</i></p>
CRUISE CONTROL		The Cruise Control is used to indicate the status of cruise control system to the driver. Lamp ON indicates cruise control feature is present and it is activated.
HILL DECENT CONTROL ON		The Hill Decent Control ON is used to indicate the status of HDC function availability but controllable and No HDC intervention by ESP system.



INSTRUMENT CLUSTER

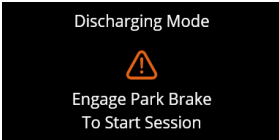

Driver Information	System Image	Description
<p>I-TPMS - ALL TIRE PRESSURE ARE OK</p>		<p>When any of the Tire Pressure drops significantly below Recommended levels then I-TPMS system tell tale comes ON with Text Message. I-TPMS screen by scrolling up or down switch on steering wheel.</p>
<p>I-TPMS - TIRE PRESSURE IS LOW</p>		<p>When there is low Tire pressure system the cluster will show the Text Warning.</p>
<p>I-TPMS - FAULT IN SYATEM</p>		<p>When there is fault in I-TPMS system the cluster will show the Text Warning.</p>

INSTRUMENT CLUSTER

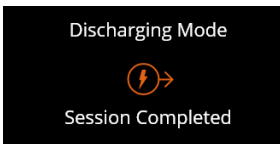

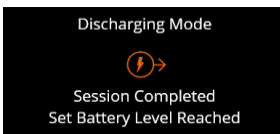
Driver Information	System Image	Description
V2X DISCHARGING (PARKING BRAKE NOT ENGAGED) - IGN ON		When Parking brake is not Engage during Discharging Mode then cluster shows "Engage Park Brake To start Session"
V2X DISCHARGING (PARKING BRAKE NOT ENGAGED) - IGN OFF		
V2X DISCHARGING (DISCHARGING MODE GUN CONNECTED) - IGN ON		When Discharging Mode Gun connected & V2x Button is pressed, then cluster shows Text Message as "Session Started"
V2X DISCHARGING (DISCHARGING MODE GUN CONNECTED) - IGN OFF		

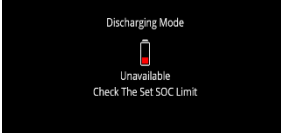

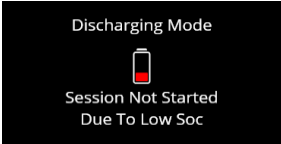
INSTRUMENT CLUSTER

Driver Information	System Image	Description
V2X DISCHARGING COMPLTED - IGN ON		When Discharging Mode session completed.
V2X DISCHARGING COMPLTED - IGN OFF		
V2X DISCHARGING COMPLTED SET BATTERY LEVEL REACHED - IGN ON		During Discharging when Session is completed then cluster will Text Message as “Session Completed Set Battery Level Reached”.
V2X DISCHARGING COMPLTED SET BATTERY LEVEL REACHED - IGN OFF		

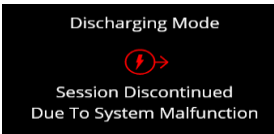

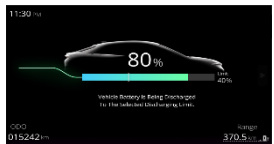
Driver Information	System Image	Description
<p>V2X DISCHARGING UNAVAILABLE - IGN ON</p>		<p>During Discharging when V2X session is Unavailable then cluster will Text Message as “Check the Set SOC Limit”.</p>
<p>V2X DISCHARGING UNAVAILABLE - IGN OFF</p>		
<p>V2X DISCHARGING NOT STARTED - IGN ON</p>		<p>During Discharging when Session is completed then cluster will Text Message as “Session Completed Set Battery Level Reached”</p>
<p>V2X DISCHARGING NOT STARTED - IGN OFF</p>		

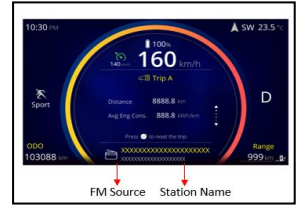

INSTRUMENT CLUSTER

Driver Information	System Image	Description
V2X DISCHARGING MALFUNCTION - IGN ON		During Discharging when V2X Malfunction observed then cluster will Text Message as “Session Discontinued Due to System Malfunction”
V2X DISCHARGING MALFUNCTION - IGN OFF		
V2X DISCHARGING - IGN ON		Default value of V2X Discharging Limit is 50%.
V2X DISCHARGING - IGN ON		

Driver Information	System Image	Description
<p>ENERGY FLOW ANIMATION AND ENERGY HISTOGRAM-FORWARD (BATTERY TO MOTOR)</p>		<p>This animation shows flow of energy from wheel to battery or battery to wheel while driving.</p>
<p>ENERGY FLOW ANIMATION AND ENERGY HISTOGRAM-FORWARD (MOTOR TO BATTERY)</p>		<p>Energy Histogram represents the instantaneous energy at any point of time and is represented in the form of line-graph</p>
<p>IVI INFO ON</p>		<p>In this feature, the IVI data including media Meta data, Navigation data is shared from HU via CAN interface to be projected on Instrument Cluster. IVI Info will not be displayed, if Settings screen is requested.</p> <p>Following are the sources information available on the cluster,</p> <ul style="list-style-type: none"> • FM and AM source icon with station name • USB device icon with music and videos names • Android Auto icon with music and navigation display • Car Play icon with music and navigation display. • Bluetooth device icon with music, calls and text information's.

INSTRUMENT CLUSTER

Driver Information	System Image	Description
DDOA SCREEN WITH DRIVER ATTENTION LEVEL 5		User can select DDOA screen by scrolling up or down switch on steering wheel.
DDOA SCREEN WITH DRIVER ATTENTION LEVEL 4		DDOA screen with Driver Attention Level 4.
DDOA SCREEN WITH DRIVER ATTENTION LEVEL 3		DDOA screen with Driver Attention Level 3 & with interrupt message for 4 seconds:

Driver Information	System Image	Description
<p>DDOA SCREEN WITH DRIVER ATTENTION LEVEL 2</p>		<p>DDOA screen with Driver Attention Level 2 & with interrupt message for 4 seconds.</p>
<p>DDOA SCREEN WITH DRIVER ATTENTION LEVEL 1</p>		<p>DDOA screen with Driver Attention Level 1 & with interrupt message for 4 seconds</p>

INSTRUMENT CLUSTER

Driver Information System (DIS) Setting

Operate the Up & down and Set Switch on steering wheel to see the Trip Info, Drive Assist, Vehicle Info, Notification, Navigation, Layout and Settings Window.

Operate the Set Switch on steering wheel to reset TRIP A, AEE A, Average Speed A, Trip Time A (When TRIP A is displayed) and reset TRIP B, Average Speed B and Trip Time B (When TRIP B is displayed).



Trip Information

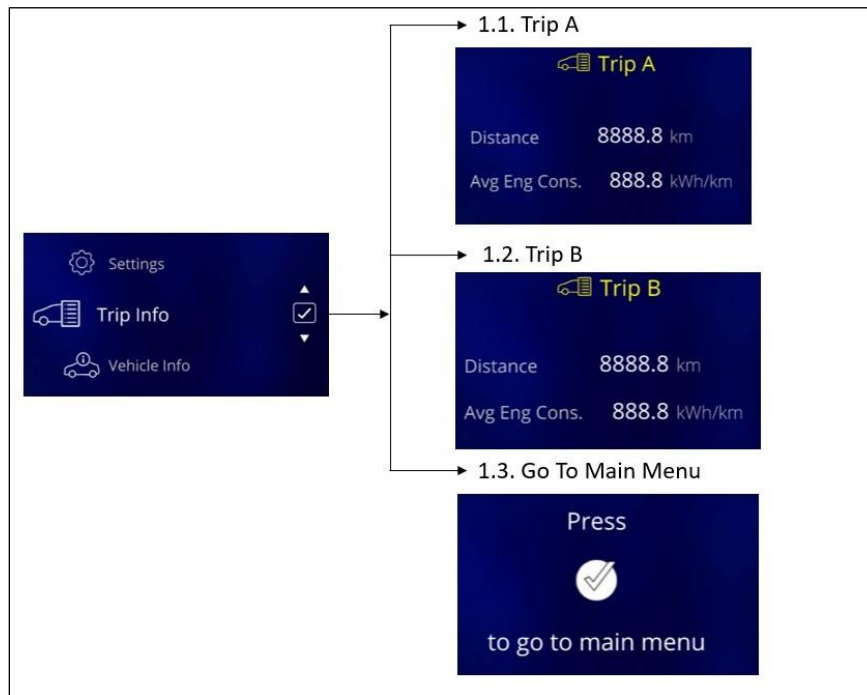

INSTRUMENT CLUSTER

Drive Assist



Vehicle Information

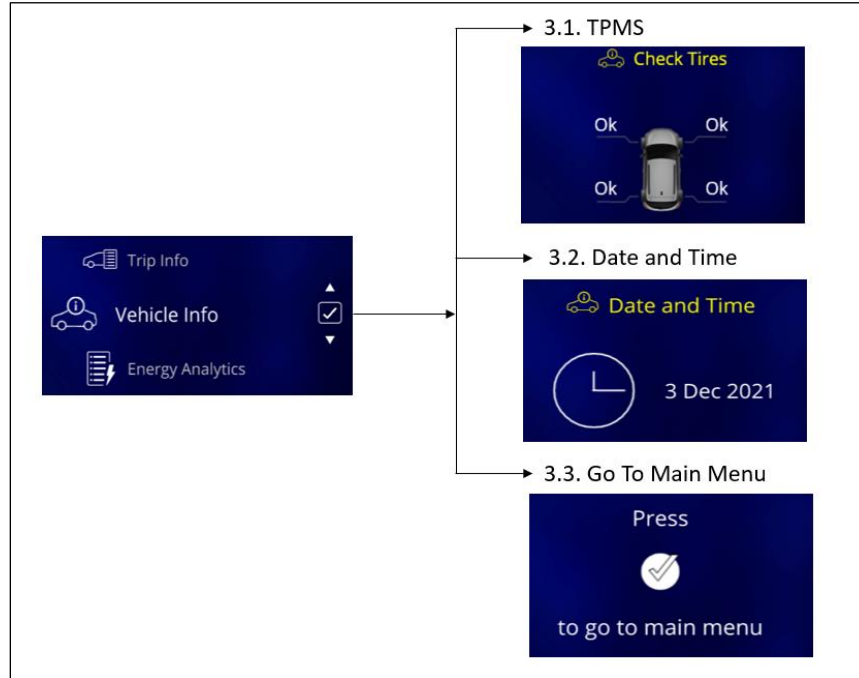

INSTRUMENT CLUSTER

Energy Analytics

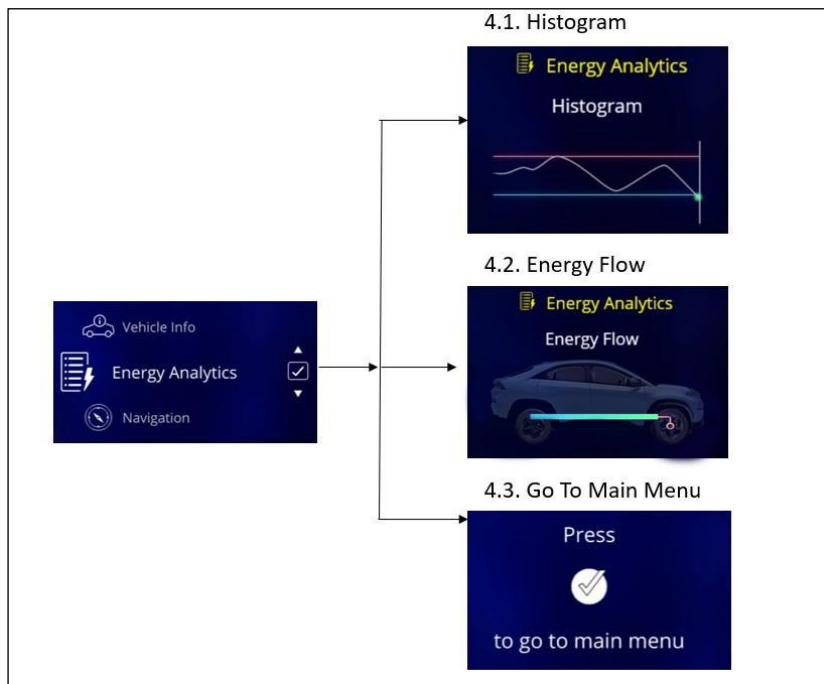

Notification

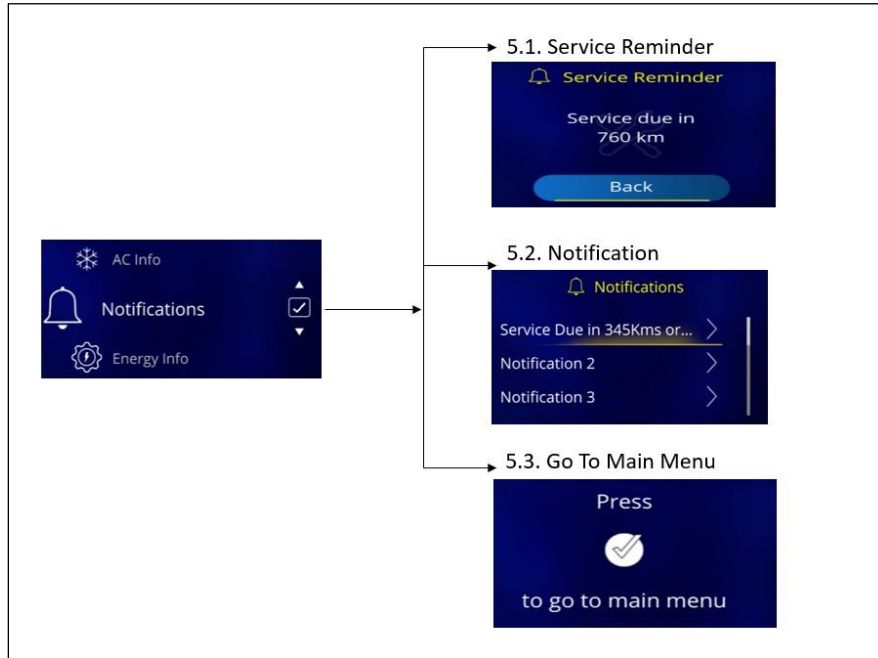

INSTRUMENT CLUSTER

Layout

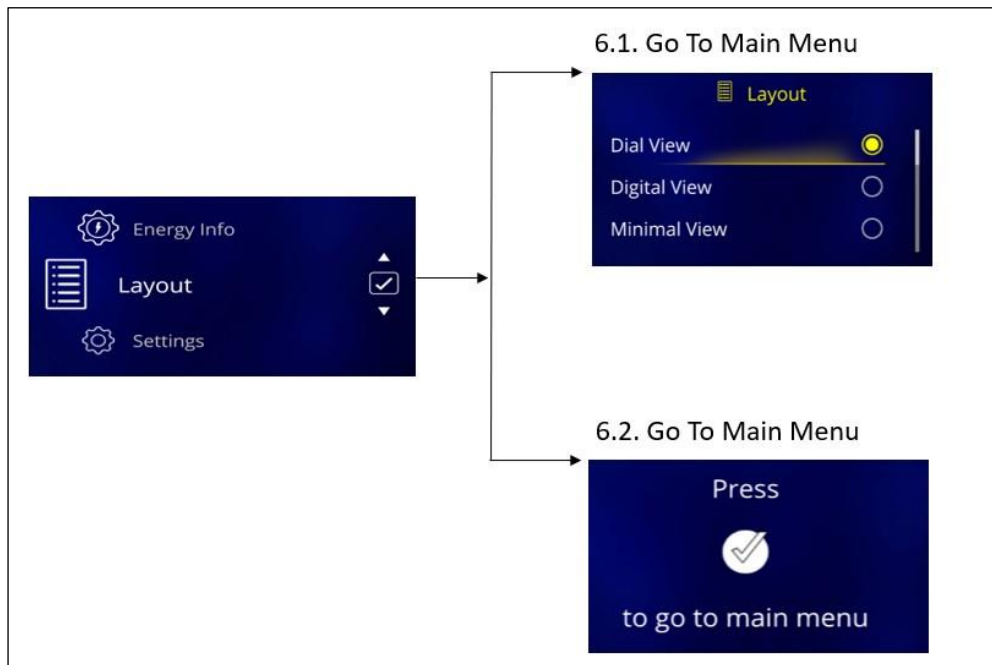

Setting Screen

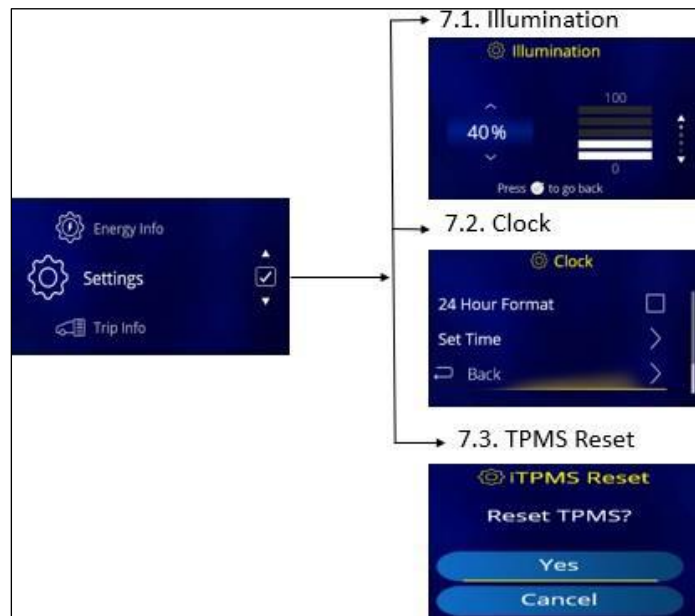

INSTRUMENT CLUSTER

DIGITAL DISPLAY (10.25" Inch) (If equipped)

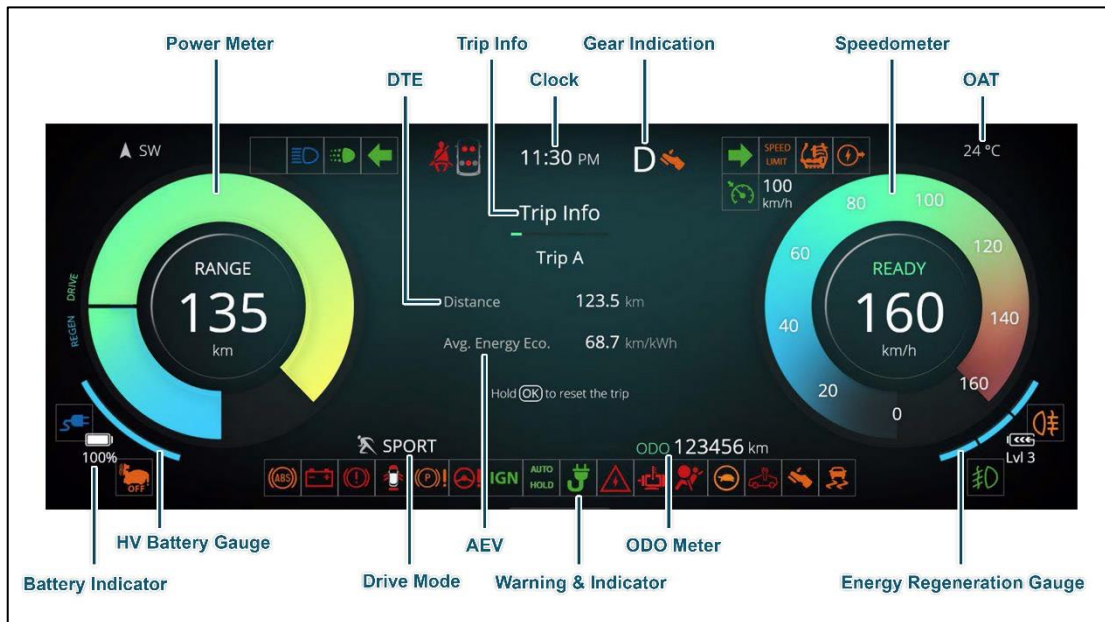

NOTE: All indicators and values are for illustration purpose only.

INSTRUMENT CLUSTER

Gauge Name	Information	Note/Warning
Speedometer	The Speedometer Indicates the actual vehicle speed in km/h	<ul style="list-style-type: none"> At every key IN and Ignition ON, the speedometer Bar moves to MAX and return to '0' position. This is welcome strategy and self-check feature In vehicle running condition if the Speedometer is not showing the Vehicle speed, then take the vehicle to TATA MOTORS EV Authorised service center.
Odometer	Odometer Indicates distance travelled by vehicle.	<ul style="list-style-type: none"> The odometer reading does not return to 0 when maximum value is reached, the display will freeze to maximum value.
SoC Gauge	SoC (State of Charge) gauge indicates the battery state of charge to user in percentage	<ul style="list-style-type: none"> When battery SoC goes below 5%, first Bar in gauge will start blinking. Do not drive the vehicle with low SoC. When the battery is low or near to empty position, low battery warning tell-tale turns Red. Pop up message is displayed to connect the charger to the vehicle for charging.
EV mode Gauge	<ul style="list-style-type: none"> This function provides instantaneous power consumption mode of vehicle during driving and displayed in the instrument cluster. During the IGN ON of the vehicle, EV mode gauge will starts sweep from REGEN mode to DRIVE mode and then back to the REGEN mode to indicate the welcome strategy behavior. 	When all functional modes are activated, then take the vehicle to TATA MOTORS EV Authorized service center.

INSTRUMENT CLUSTER

Gauge Name	Information	Note/Warning
	<ul style="list-style-type: none"> For DRIVE mode, LED BARs will be ON as per the power consume 	
Distance To Empty (DTE)	<ul style="list-style-type: none"> Range indicates approximate distance (km) that the vehicle can travel with current battery charge. Range shall be indicated both in IGN ON & IGN OFF conditions. In IGN OFF when charger is connected and charging is happening then Range value will display as long as screen is activated in the cluster. 'RECHARGE' shall be displayed which indicates that it's the time to take your vehicle to the nearest charging station and the distance that a vehicle can travel with current charge is 20 Kms. 	<ul style="list-style-type: none"> If Range is displayed as '—', take vehicle to TATA MOTORS EV Authorised Service Centre station. The Range values may vary significantly based on driving conditions, driving habits, and condition of the vehicle. The Range value is an estimate of the available driving distance. Change of distance unit is not applicable.
Regeneration Level Selection	<ul style="list-style-type: none"> This function provides Regeneration Level settings to user from Minimum to Maximum in steps of Level 0, Level 1, Level 2 and Level 3 of vehicle during driving and displayed in the instrument cluster 	<ul style="list-style-type: none"> The "Maximum" Regen Level setting provides the maximum amount of regenerative braking power & it recaptures the most energy and reduces wear & tear on the brakes.

Gauge Name	Information	Note/Warning
		<ul style="list-style-type: none"> The “Minimum” Regen Level setting incorporates a reduced regenerative braking force that recaptures less energy but allows the vehicle to coast further than in the “Maximum” Regen Level.

State of Charge (SOC) Gauge for High Voltage Battery

Provided in the instrument cluster as a tell-tale. It shows the charging status of the high voltage battery. Low charge or minimum position on the indicator indicates that there is not enough energy in the high voltage battery.

Full charge or max position indicates that the HV battery is fully charged.

- When driving on highways, make sure to check in advance if the HV battery is charged enough.
- When the bar turns red on the high voltage charge indicator, the low charge warning lamp turns ON to alert you of the battery level.
- At <25% SoC, Sports mode cannot be selected. Max speed can be attained. At <10% SoC, limp mode gets activated and speed limits are triggered.



INSTRUMENT CLUSTER

Action to be Taken When Charging Stops Abruptly

- Check the reason for interruption of charging. (Refer 'Troubleshooting guide for Normal Charging' table).
- Switch off the AC supply.
- Remove the charging gun from the charging inlet.
- Wait for 5 minutes.
- Restart the charging. (Refer charging procedure).

Cleaning of Charging Inlet

Covering the charging gun and charging inlet by dust cap will ensure protection from water and dust.



Precautions to be Taken While Cleaning the Charging Inlet

- Keep the vehicle lid always closed
- When the lid is open ensure that dust caps are in closed position
- During normal charging, make sure that DC charging cap is closed
- In case of any dust/mud/snow accumulation in the charging port and also on CCS2 especially actuator area, it can be cleaned with blowing air before charging.
- Allow the water to drain completely through drain holes. Allow the charging port to dry completely.



NOTE

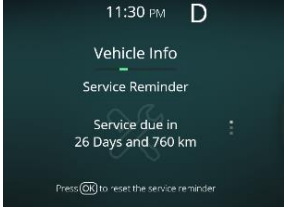

Water entering into the charging port will always be drained through the drain system. If water is stagnant in charging port area call TATA MOTORS EV Authorised service centre to rectify the issue.

DRIVER INFORMATION SYSTEM (DIS)



Driver Information	System Image	Description
<p>SERVICE RE-MINDER</p>		<p>This indicates how many days/kilometres are left until service is due. If service is overdue, it will display “0” km or “0” days and a spanner symbol will blink every time ignition is ON for a few seconds. Never reset the display between service intervals as it may give incorrect readings. The information is retained in the service interval display even after the vehicle battery is disconnected.</p> <p>Note: 1. This option is for indicative purpose only. Keep track of your odometer reading and follow the maintenance schedule. 2. Spanner symbol will be continuously “ON” when service is overdue.</p>
<p>OUTSIDE AMBIENT TEMPERATURE</p>		<p>This displays outside ambient temperature in units of °C with the resolution of 1°C.</p> <p>Note: The temperature sensor is in the front bumper of the vehicle, therefore the temperature reading can be affected by heat reflection from the road surface. This can cause an incorrect temperature reading when speed is under low speeds or when stopped.</p> <p>If display shows ‘ - - ’, take your car to TATA MOTORS EV Authorised Service Centre.</p>



INSTRUMENT CLUSTER

Driver Information	System Image	Description
<p>DOOR AJAR (if equipped)</p>		<p>This feature monitors the Door Input and warns Driver if any Door or trunk lid is open</p> <p>Note: If any other door is open roof lamp will be 'ON' provided that roof lamp switch is in ON position.</p>
<p>CURRENT GEAR INDICATION</p>		<p>Current gear engaged by the transmission shall be displayed on DIS.</p> <p>Note: If is displayed, it means 'Fault' condition. In such case, take vehicle to authorized TATA MOTORS EV Authorised service Centre.</p>
<p>TPMS (TYRE PRESSURE MONITORING SYSTEM)</p>		<p>User can select TPMS screen by scrolling up or down.</p> <p>TPMS system tell tale comes ON with Tire pressure value near the respective Tire with Recommended level" Text Message.</p>



Driver Information	System Image	Description
<p>TPMS - MALFUNCTION</p>	 <p>The image shows a top-down view of a car with a red exclamation mark in the center. Above the car, the text reads: "Vehicle Info", "TPMS Malfunction", and "Contact Service Centre".</p>	<p>TPMS MALFUNCTION CONTACT SERV CENT” text warning comes ‘ON’ for 4 seconds when TPMS system malfunction. Take your vehicle TATA MOTORS EV Authorised Service Centre.</p>
<p>TPMS - LOW TYRE PRESSURE</p>	 <p>The image shows a top-down view of a car with red exclamation marks on the front-left and front-right tires. Above the car, the text reads: "Vehicle Info", "Low Tyre Pressure", and "Inflate Tire".</p>	<p>When any of the Tire Pressure drops significantly below Recommended levels then TPMS system tell tale comes ON with “Low Tire pressure In-flate Tire” Text Message.</p>
<p>TPMS - HIGH TYRE PRESSURE</p>	 <p>The image shows a top-down view of a car with red exclamation marks on the front-left and front-right tires. Above the car, the text reads: "Vehicle Info", "High Tyre Pressure", and "Deflate Tire".</p>	<p>When any of the Tire Pressure increase significantly above Recommended levels then TPMS system tell tale comes ON with “High Tire pressure De-flate Tire” Text Message.</p>

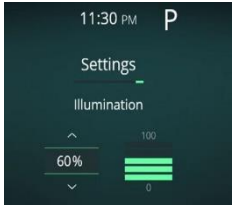
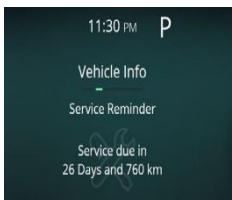

INSTRUMENT CLUSTER

Driver Information	System Image	Description
TPMS - AIR LEAKAGE	 <p>The image shows a top-down view of a car with red exclamation marks on all four tires. The text reads: "Vehicle Info", "Leakage Detected", "Check Tires".</p>	<p>When any of the Tire Pressure drops significantly below Recommended levels then TPMS system tell tale comes ON with “Leakage Detected Check Tires” Text Message.</p>
TPMS - TIRE OVER-LOAD	 <p>The image shows a top-down view of a car with red exclamation marks on all four tires. The text reads: "Vehicle Info", "Tire Overheated", "Slow Down".</p>	<p>When any of the Tire Pressure increase significantly above Recommended levels then TPMS system tell tale comes ON with “Tire Overheated slow down” Text Message.</p>
SETTINGS SCREEN	 <p>The image shows a settings menu with the time 11:30 PM and a 'P' indicator. The menu items are: "Settings", "Illumination", "Units", "Dial View", and "Secondary Area Info", each with a right-pointing arrow.</p>	<p>User can enter into setting screen by pressing select button while being in setting screen. Screen get displayed into setting screen</p>

Driver Information	System Image	Description
<p>ILLUMINATION SETTING</p>		<p>User can select Illumination Setting by Scroll down & pressing Set Button in Setting Screen provided park lamp ON. User can increase the illumination from (20% to 100%) in 5 steps by using UP & SET Button.</p> <p>User can decrease the illumination from (100% to 20%) in 5 steps by using DOWN & SET Button.</p>
<p>SERVICE REMINDER RESET</p>		<p>User can select Service Reminder Screen by Scroll down & pressing Set Button in Setting Screen.</p> <p>User can reset (Yes / Cancel) the Service Reminder by UP / DOWN & SET Buttons.</p> <p>Note: <i>In the Setting menu if there is no user input for 10 secs the previous screen shall be displayed.</i></p>
<p>SLOW CHARGE UP TO 100%</p>		<p>It is recommended to slow charge vehicle to 100% SOC to ensure consistent performance and better health of high voltage battery. Once this message appears in cluster, it is recommended that user slow charges vehicle's high voltage battery to 100% SOC.</p>

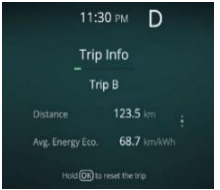

INSTRUMENT CLUSTER

Driver Information	System Image	Description
COMPASS SCREEN		Compass Feature shall be used for navigation and orientation that shows direction relative to the geographic cardinal directions
CHARGING LIMITS		Set charging limit of the battery. The target charging level can be changed by 10%. Once the charging is completed as per set limit, the message is displayed
CRITICAL BATTERY (THERMAL RUNAWAY) MALFUNCTION		This message will appear in cluster along with audio warning to “Evacuate the vehicle”. In case there is a critical malfunction in high voltage battery which can lead to thermal damage, this message will appear in cluster. Customer is recommended to park vehicle in safe zone and evacuate to avoid injury.

Driver Information	System Image	Description
<p>AVERAGE ENERGY ECONOMY FOR TRIP A AND TRIP B</p>		<p>Displays “Average Energy consumption” for trip A or B since it was reset Resolution: 0.1 Wh/Km Average Energy Consumption shall Reset to 0 when respective Trip meter is reset. Average Energy Economy shall be displayed as ‘—.’for initial 0.5 km of respective trip. Once 0.5 km distance is covered, Average Economy shall be displayed.</p>
		<p>Even after 0.5 km distance covered for particular trip, Average Energy economy is displayed as ‘—’take vehicle to TATA MOTORS EV Authorised Service Centre. Note: <i>AEE value is estimate of Energy economy. It may vary significantly based upon driving conditions, driving habits and condition of vehicle. Average Energy Consumption shall get reset to 0 when Battery is removed and refitted.</i></p>
<p>DISTANCE TO EMPTY</p>		<p>DTE indicates approximate distance (km) that the vehicle can travel with current battery charge. DTE shall be indicated both in IGN ON & IGN OFF conditions. In IGN OFF when charger is connected and charging is happening then DTE value will display as long as screen is active in the cluster. ‘RECHARGE’ shall be displayed which indicates that it’s the time to take your vehicle to the nearest charging station and the distance that a vehicle can travel with available battery based on the driving pattern.</p>

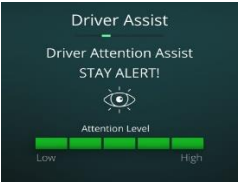
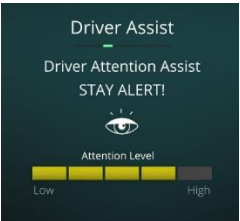
INSTRUMENT CLUSTER

Driver Information	System Image	Description
<p>INFOTAINMENT INFORMATION ON INSTRUMENT CLUSTER DISPLAY UNIT</p>		<p>The instrument cluster will display information like media, navigation and FM.</p>
<p>DDOA SCREEN ATTENTION LEVEL - 5</p>		<p>User can select DDOA screen by scrolling up or down switch on steering wheel. DDOA screen with Driver Attention Level 5 (Attention Level in Green Color)</p>
<p>DDOA SCREEN ATTENTION LEVEL - 4</p>		<p>DDOA screen with Driver Attention Level 4 (Attention Level in Yellow color)</p>

Driver Information	System Image	Description
<p>DDOA SCREEN ATTENTION LEVEL - 3</p>		<p>DDOA screen with Driver Attention Level 3 (Attention level In Amber Color) & with interrupt message for 4 seconds</p>
<p>DDOA SCREEN ATTENTION LEVEL - 2</p>		<p>DDOA screen with Driver Attention Level 2 (Attention level In A light RED color) & with interrupt message for 4 seconds</p>
<p>DDOA SCREEN ATTENTION LEVEL - 1</p>		<p>DDOA screen with Driver Attention Level 1 (Attention Level in RED color) & with interrupt message for 4 seconds</p>

INSTRUMENT CLUSTER

Driver Information System (DIS) setting (if equipped)

Operate the Up & down and Set Switch on steering wheel to see the Trip Info, Drive Assist, Vehicle Info, Notification, Navigation, Layout and Settings Window.

Operate the Set Switch on steering wheel to reset TRIP A, AEE A, Average Speed A, Trip Time A (When TRIP A is displayed) and reset TRIP B, Average Speed B and Trip Time B (When TRIP B is displayed).

Option I



Option II



Trip Information



INSTRUMENT CLUSTER

Vehicle Information

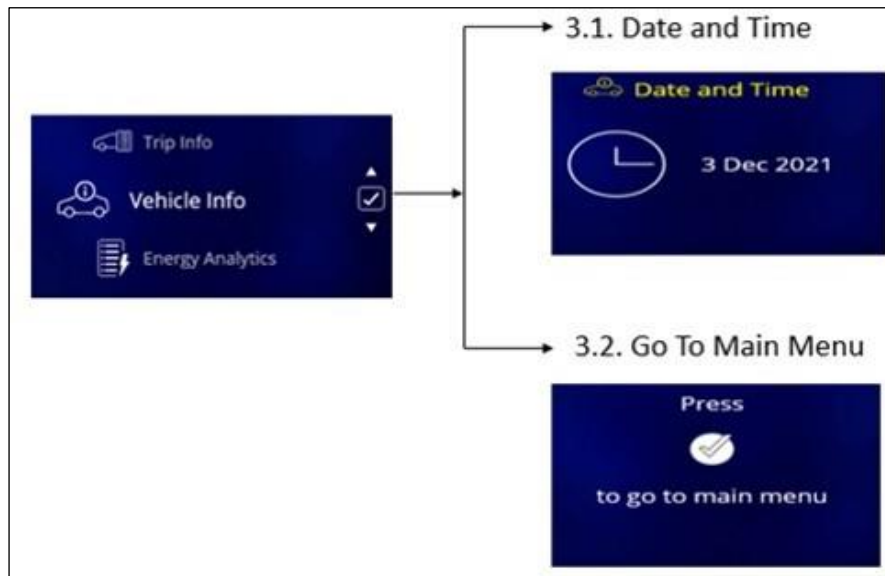

Energy Analytics

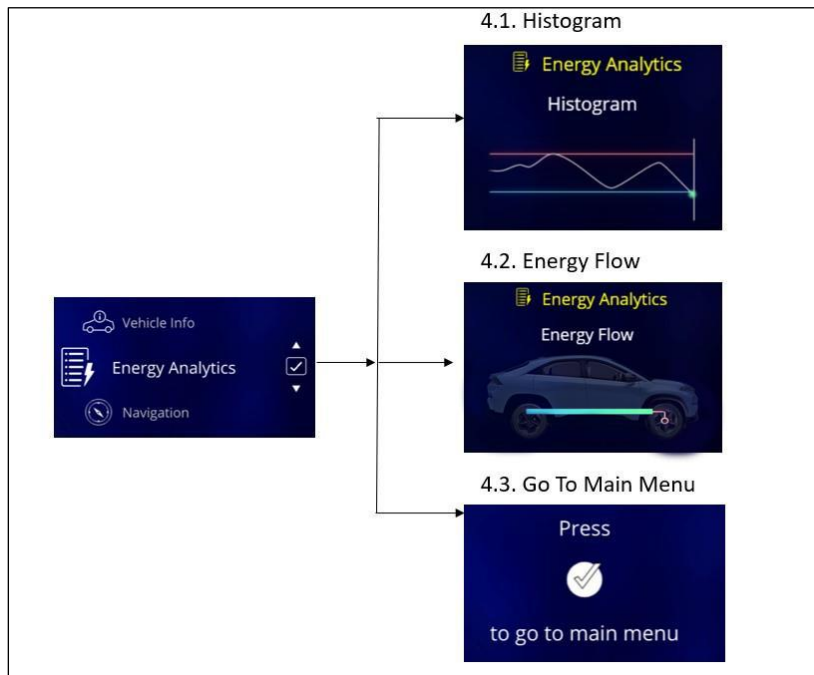

INSTRUMENT CLUSTER

Notification

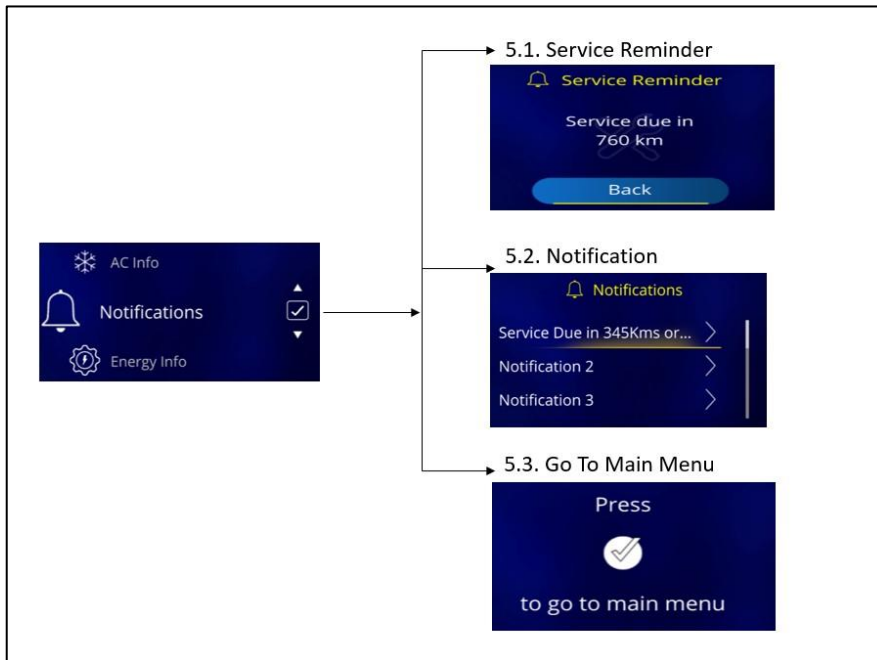

Layout

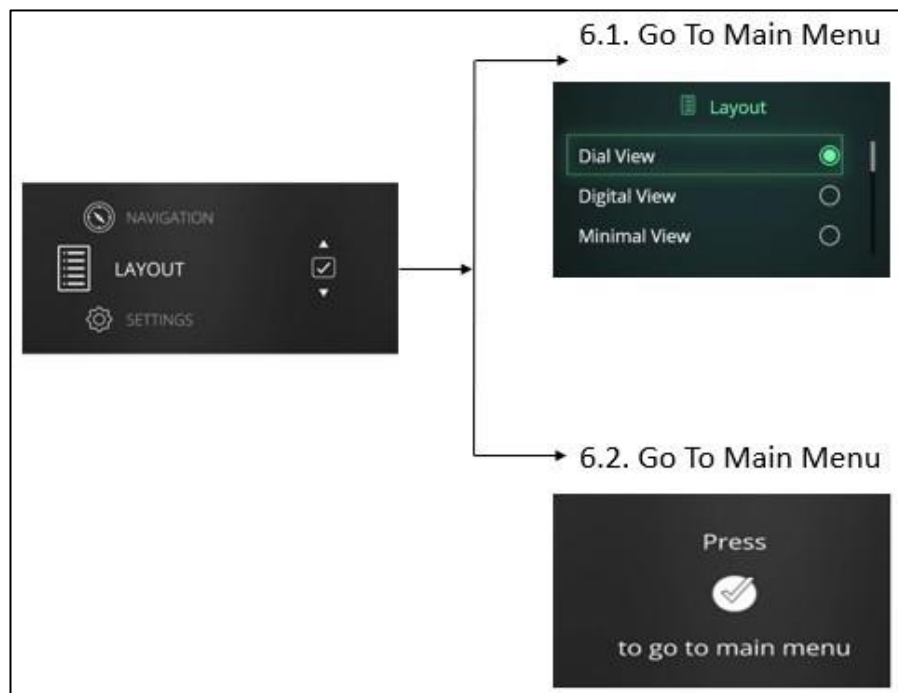

INSTRUMENT CLUSTER

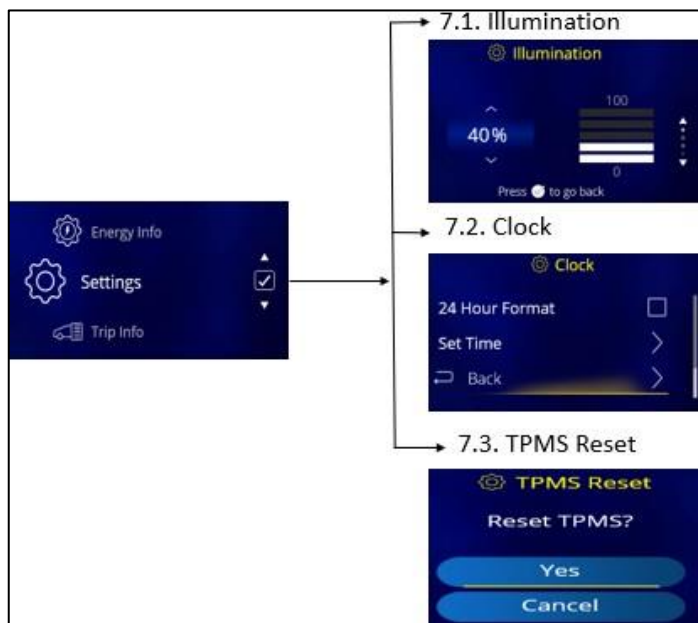

Setting Screen

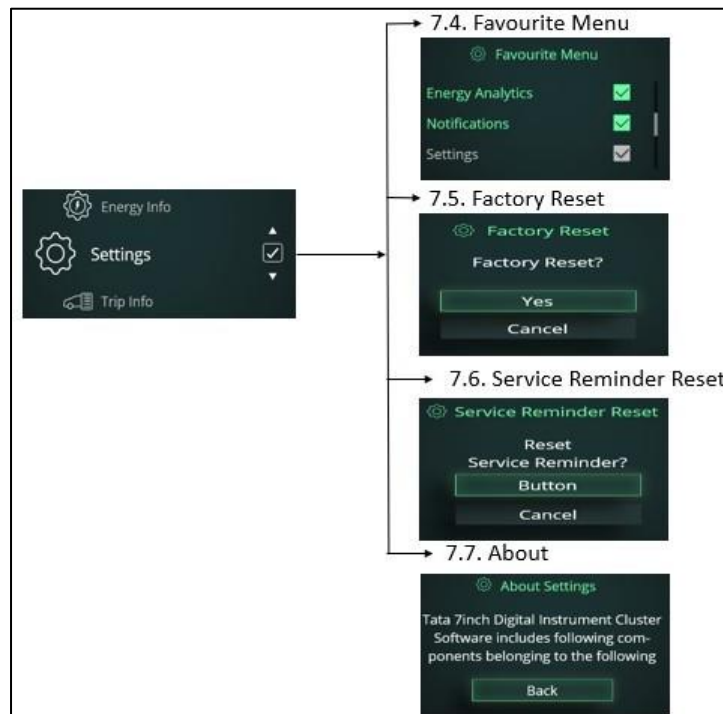











INSTRUMENT CLUSTER

WARNING AND INDICATORS







Warning Lamps	Color	Indicator	Remarks
Service Indicator	Amber / Red	 The indicator consists of two car icons. The top one is yellow (Amber) and the bottom one is red.	<p>In case of Power Train Sensors (AC Charging Inlet Temperature Sensor, AC Linear Pressure Sensor etc.) & Actuators (Fan, Pump, Regen Switch, Eco / Sport Switch etc.) failure then this Amber indicator will glow.</p> <p>When there is high severity then Red indicator will glow. Please take your vehicle to nearest TATA MOTORS EV Authorised Service Centre at the earliest.</p>
Immobilizer	Red	 A red icon of a car with a padlock symbol on the front, indicating the immobilizer system.	<ol style="list-style-type: none">1. This lamp comes on when the system disables vehicle start if the original key is not used.2. Lamp blinks: Vehicle is in immobilized condition when key is not inserted.3. Lamp ON: Problem with key/system. Contact a TATA MOTORS EV Authorized Service Centre.4. Lamp OFF: Normal condition (Authenticated user) and vehicle will start.
Turn Signal	Green	 Two green arrows pointing left and right, indicating the turn signal function.	<p>Indicates direction indicated by the turn signal.</p> <p>Blinks along with buzzer while operating left/right turn indicator only when ignition is switched 'ON'. The direction indicator arrow on Instrument Cluster flashes along with external indicator lights as selected. Both Tell tales shall blink simultaneously when Hazard switch is pressed irrespective of Ignition ON and the Tick-Tock sound shall be given when any one or both the Tell tales are ON.</p>

Warning Lamps	Color	Indicator	Remarks
High Beam	Blue		This lamp comes on when the high beam headlamps are switched 'ON' or flashed.
LV Battery charging	Red		This symbol lights up when the 'IGN' is turned 'ON' and should go 'OFF' after the vehicle starts. Note: If it remains 'ON' while the vehicle is running, it indicates that the battery is not getting charged. Switch off all unnecessary electrical equipment and get the problem attended at TATA MOTORS EV Authorised Service Centre.
Airbag status	Red		This lamp comes on when ignition is switched 'ON' and goes 'OFF' in approx. 4 seconds. If it continuously remains on or blinks then contact the TATA MOTORS EV Authorised service Centre immediately.
Park Brake / Brake Fluid Low / EBD malfunction	Red		Illuminates momentarily when ignition is switched 'ON'. Once parking brake is released, it turns 'OFF'. If it remains 'ON', it indicates. <ol style="list-style-type: none"> 1. Brake fluid level is low. 2. Park brake is applied & turns 'OFF' when it is released. 3. ABS/EBD system has a fault.
Cruise Control lamp (if equipped)	Green		This symbol lights up when the 'IGN' is turned 'ON' and shall go 'OFF' after 4 sec. The Cruise Control is used to indicate the status of cruise control system to the driver. Lamp ON indicates cruise control feature is present and it is activated.



INSTRUMENT CLUSTER

Warning Lamps	Color	Indicator	Remarks
EPAS	Amber		Illuminates momentarily when ignition is switched 'ON'. Illuminates when there is a fault in the EPAS. Contact the TATA MOTORS EV Authorized Service Centre immediately.
AVH Indicator (If equipped)	Green		AVH Indicator turns 'ON' for 4 seconds, when ignition is turned 'ON' irrespective of input state. This feature monitors AVH function in ESP system and warns the driver in case of AVH function malfunction.
ABS	Amber		Illuminates when ignition is switched 'ON' and goes 'OFF' in 3 seconds. Illuminates continuously if there is any malfunction in ABS. Normal braking system will be operational without assistance of ABS. Contact a TATA MOTORS EV Authorized Service Centre immediately.
SEAT BELT REMINDER	Red		The seatbelt warning indicator remains ON for 4 seconds, when ignition is turned ON. The warning lamp remains ON till all occupied seats belts are buckled. If seatbelt remains unbuckled and vehicle speed goes beyond 17 kmph, then final audio warning will go more than 90 seconds Note: Once the seatbelts are fastened, the buzzer and warning lamp turns OFF. Seatbelt reminder remains OFF when reverse gear is engaged.







INSTRUMENT CLUSTER

Warning Lamps	Color	Indicator	Remarks
Key Not Detected (if equipped)	Amber		This lamp comes on when the Valid Smart key is not detected inside the vehicle.
Press / Brake Pedal to Start vehicle (if equipped)	Amber		This lamp comes on with IGN ON till user presses the brake pedal to start the vehicle.
Daytime running lamps DRL (if equipped)	Green		This lamp comes on when the Daytime Running lamp is 'ON'.
Door Ajar lamp (if equipped)	White / Red		All four door and Tail gate are indicated independently when the respective door or tail gate is open.
ECO	White		Illuminates momentarily when ignition is switched 'ON'. When ECO lamp is ON, it indicates the car is in 'Economy' drive mode.
CITY	White		Illuminates momentarily when ignition is switched 'ON'. If CITY lamp is ON, it indicates 'City' drive mode, which is default mode.







INSTRUMENT CLUSTER

Warning Lamps	Color	Indicator	Remarks
SPORT	White		This symbol comes ON when SPORT driving mode is activated.
Speed limit warning indicator	Amber		<p>When the vehicle speed crosses 80 kmph, then speed limit warning indicator turns 'ON' along with an audio chime for every two minutes (audible warning). When the vehicle speed is reduced below 75 kmph, then the speed limit warning indicator and the audio warning will turn off.</p> <p>If vehicle speed crosses 120 kmph, the speed limit warning indicator flashes along with an audio warning for every two sec one beep (audible warning) until the vehicle speed is above 120 kmph.</p> <p>When the vehicle speed is reduced below 115 kmph, then speed limit warning indicator turns 'ON' along with an audio chime for every two minutes one beep (audible warning)</p>
iTPMS / TPMS (Isolated/Non-Isolated)	Amber		<ol style="list-style-type: none"> 1. This symbol comes ON and blink for 4 second if Tyre Pressure is LOW/HIGH, Tyre temperature is HIGH, Tyre air pressure leakage. After 4 second symbol will continuously ON till warning is present. 2. This symbol comes on and blink for 10 second if TPMS/I-TPMS system has fault and TPMS/I-TPMS Sensor fault / missing. After 10 second symbol will continuously ON till fault is present, Please take your vehicle to nearest TATA MOTORS EV Authorised Service Centre at the earliest.





INSTRUMENT CLUSTER

Warning Lamps	Color	Indicator	Remarks
HDC Warning lamp (if equipped)	Amber		Illuminates if Hill Decent Control System is activated. If continuously ON then HDC system is at fault condition, Please take your vehicle to nearest TATA MOTORS EV Authorized service Centre at the earliest.
HDC ON (if equipped)	Green		Illuminates momentarily when ignition is switched 'ON'. This symbol comes on when the HDC function is activated in the vehicle.
HHC warning lamp (if equipped)	Amber		Illuminates momentarily when ignition is switched 'ON'. If continuously on then HHC, system is in fault condition. Please take your vehicle to TATA MOTORS EV Authorised service Centre at the earliest.
Limp Home Mode	Amber		This symbol indicates the vehicle gone into limited performance mode. This usually happens when the battery reaches 10% threshold or if there is any minor fault in power transmission or electrical components.
Park Lamp Indicator	Green		Park Lamp Indicators used to display/Indicate the Position Lamp to Driver.
Charging Fail Indicator	Red		This symbol is displayed when the vehicle is not getting charged even if the charger is connected. Contact the TATA MOTORS EV Authorized Service Centre to get the charging fail issue resolved





INSTRUMENT CLUSTER

Warning Lamps	Color	Indicator	Remarks
Charger Connected	Blue		This symbol lights up as soon as the charger is connected for charging the battery
Charging Indicator	Green		This symbol is displayed when your vehicle is getting charged.
Charger Connect Fail	Grey		This symbol lights up in case the charger is not connected properly. Check the connection again and if the problem persists Contact the TATA MOTORS EV Authorized Service Centre.
Motor High Temperature	Red		This symbol lights up when the temperature of the motor is higher, and motor becomes hot. Park your vehicle safely and wait for the temperature to become normal. If the problem persists, contact the TATA MOTORS EV Authorized Service Centre
Battery High Temperature	Red		This symbol lights up when the temperature of the battery is higher, and battery becomes hot. Contact the TATA MOTORS EV Authorized Service Centre if this indicator is getting on frequently.
Drive Ready	Green		This symbol indicated that your vehicle is ready to drive

INSTRUMENT CLUSTER

Warning Lamps	Color	Indicator	Remarks
High Voltage (HV) Alert	Red		This symbol lights up the voltage of the battery is too high and cause damage. Park your vehicle safely and contact the TATA MOTORS EV Authorized Service Centre.
zero charge/Low Charge	Red		This feature provides the HV battery Low/Zero Charge Status to the user. A bulb check shall be performed for this TT at every IGN ON for 4 seconds. The TT shall remain ON irrespective of the Input state during these 4 seconds. This tell- tale shall be controlled turned ON/OFF by receiving the SoC input when the SoC level is low TT will turn ON to indicate charging system battery low to the user.
AC ON	Blue		This feature provides AC status to user. A bulb check shall be performed for this TT at every IGN ON for 4 seconds. The TT shall remain ON irrespective of the Input state during these 4 seconds. This Tell-tale is ON when AC is turn ON by user.
EPB MIL Fault	Amber		In case of malfunction in EBP MIL function in ESP system this indicator will glow. Please take your vehicle to nearest TATA MOTORS EV Authorised Service Centre at the earliest
AUTO Vehicle HOLD(AVH) Warning	Amber		In case of malfunction in AVH function in ESP system this amber indicator will glow. Please take your vehicle to nearest TATA MOTORS EV Authorised service centre at the earliest.

INSTRUMENT CLUSTER

Warning Lamps	Color	Indicator	Remarks
ESP (if equipped)	Amber		Illuminates momentarily when ignition is switched 'ON'. If continuously ON then ESP system is at fault condition, Please take your vehicle to nearest TATA MOTORS EV Authorised Service Centre at the earliest.
V2X Charging	Amber		This Tell-tale informs driver about V2X Discharging information to the user.
V2X Warning	Red		This Tell-tale informs driver about V2X Discharging fault information to the user.
AVAS Malfunction	Amber		This feature is used to generate the Engine Sound/Alert in EV vehicle the since there is no sound from the Motor used in EV vehicle to drive This symbol indicates the sound function feature is not working properly.

DISPLAY MESSAGES ON INSTRUMENT CLUSTER (if equipped)

Warning Messages

S N	Warning / Information Title	Warning Message Title	Warning Message On Instrument Cluster
1	Fasten Seat Belt - Driver	Seat Belt Reminder	Fasten Driver Seat Belt
2	Speed Limit Warning	Speed Limit Warning	Over Speeding Detected Slow Down
3	Drive Control Shift Denied	Drive Mode Warning	Drive Control Shift Denied
4	Hill Hold Control Failure	Hill Hold Control	Malfunction Detected Contact Service Center
5	Hill Decent Control Failure	Hill Decent Control	Malfunction Detected Contact Service Center
6	Charging Level Low State	Charging Level Warning	Charging Level Low
7	Fasten seat belt front passenger	Seat Belt Reminder	Fasten Front passenger Seat Belt
8	Transmission Failure Limp home Activated Visit Service Center	Transmission System	Malfunction Detected Contact Service Center
9	ORVM Indicator Failure	Rear ADAS Features Impacted	Contact Service Center

INSTRUMENT CLUSTER

Alert Messages

S N	Alert / Information Title	Alert Message Title	Action To Be Taken
1	Service Reminder Days	Service Due in/Service Overdue by "value" days	Contact to TATA MOTORS EV Authorised Service Centre
2	Park Brake Engaged	Brake Alert	Park Brake Engaged
3	Charging Full	Battery Fully Charged	Remove Charger Safely
4	Service Reminder Kms	Service Due in/Service Overdue by "value" km	Contact to TATA MOTORS EV Authorised Service Centre
5	Charging below 100%	Battery XX% Charged Range YYY kms	Remove Charger Safely
6	Auto Headlamp	Lamp Alert	Auto Headlamp Activated
7	Battery Low & user changes gear to S	Sport Mode Not Recommended	Change gear to any Eco or City mode
8	Charging ON Park brake OFF	Engage Park Brake to Start Charging	Engage Park Brake to Start Charging
9	HV Critical alert	Critical Alert Contact Service Center	Contact TATA MOTORS EV Authorised Service Centre
10	Slow Down Vehicle Speed	Slow Down to Turn OFF Vehicle	Press the brake pedal to slow down vehicle
11	Slow Charge up to 100%	Slow Charge up to 100%	It is recommended that user slow charges vehicle's high voltage battery to 100% SoC.
12	Critical Battery Malfunction	Park vehicle safely and Evacuate Immediately	It is recommended to park vehicle in safe zone and evacuate to avoid injury.

Interrupt Messages

S N	Alert / Information Title	Action To Be Taken
1	Rotate steering wheel (In ESCL jam condition)	Press Start Button while Turning Wheel
2	Drive Alert - Tea Break	Take a Break
3	Steering Failure-Visit Garage	Steering Failure Contact Service Center
4	Steering Failure-Stop Driving	Steering Failure Stop the Vehicle Safely
5	Door Ajar	Close the door
6	ESCL	Press Start Button While Turning Wheel
7	No Key	Smart Key Out of Range
8	Low Key Battery	Smart Key Battery Low Replace Battery
9	Press Brake Pedal	Press Brake Pedal to Start Vehicle
10	Drive Modes	Respective drive mode
11	Release Park Brake	Press Brake Pedal to Release Park Brake
12	Happy Birthday	Happy Birthday

INSTRUMENT CLUSTER

AUDIO REMINDERS

S N	Feature	Condition	Reminder
1	Parking Lamp 'ON' Reminder	If you forget to turn OFF the park lights and driver door is open	An audio warning will be started. Do not forget to turn OFF your park lights as it may drain the vehicle's battery.
2	Parking brake 'ON' reminder	If Park Brake is applied and vehicle is driven above 5 Km/h, tell-tale shall blink along with chime continuously. Disengage the park brake to stop the warning.	Tell-tale will turn 'ON' and buzzer will provide audio warning continuously. Disengage the park brake to stop audio warning.
3	Driver Seat Belt reminder	If seatbelt is not fastened and vehicle goes above 13 kmph	Then final audio warning will go on for more than 90 seconds. Seat belt tell-tale light will remain continuously ON when audio alarm is active.
4	Front passenger Seat Belt reminder	If front passenger has not fastened seat-belt and if vehicle speed goes above 13 kmph, then final audio warning will go on for more than 90 seconds.	Seat belt tell-tale light will remain continuously ON when audio alarm is active. Note: <i>Fasten the seatbelt to stop audio warning.</i>
5	Drive mode chime	When user switches drive mode from city to eco or city to sport (if equipped)	Sound warning for 1 second will be given to alert user.

INSTRUMENT CLUSTER

S N	Feature	Condition	Reminder
6	Electronic Steering Column Lock (ESCL) chime	This feature informs the driver to rotate steering wheel when ESCL gets engaged inadvertently.	This chime is sounded in IGN OFF mode for 3 secs.
7	High Temperature alert for Motor	When machine and inverter temperature cross the max limit from the BMS	Buzzer will start along with the motor high temperature warning lamp blinking to indicate the user to contact TATA MOTORS EV Authorised Service Centre. Tell-tale and buzzer will be in sync continuously till the state re- mains TRUE.
8	iTPMS / TPMS chime	If, Tyre Pressure is low Tyre Pressure is high Tyre temperature is high Tyre air pressure leakage If, iTPMS/TPMS system has fault TPMS Sensor fault or missing	iTPMS / TPMS chimes shall sound for 4 secs and for iTPMS / TPMS fault conditions TPMS/ iTPMS chime shall sound for 10 sec.
9	PEPS Key not detected chime	If PEPS key is not detected in the vehicle	Sound warning will be given to alert User

INSTRUMENT CLUSTER

S N	Feature	Condition	Reminder
10	Low battery charging Chime	When Auxiliary battery charging fault occurs with high criticality, buzzer will start along with the warning lamp blinking to indicate the user to contact TATA MOTORS EV Authorised Service Centre.	Warning lamp and buzzer will be in alert continuously till the state remains TRUE.
11	Charging ON & Park Brake OFF Chime	When charger is connected & Park brake is disengaged.	Sound will be given to alert user.
12	Cell Voltage Low Fault chime	If iTPMS/TPMS alert condition occurs, iTPMS/TPMS chimes shall sound for 4 secs and for iTPMS/TPMS fault conditions.	Sound will be given to alert User for 10sec.
13	Rear Seat Belt reminder	If Rear Passenger is present & its seat belt remains unbuckled and vehicle speed goes above 13 km/hr, Final Warning will start.	Audio Chime will continue for 93 seconds. Seat belt tell tale will remain continuously ON when audio alarm is active.
14	High Temperature alert for Battery	When maximum battery cell temperature crosses the limit specified	Sound will start along with the battery high temperature warning lamp blinking to indicate the user to contact TATA MOTORS EV Authorised Service Centre. Warning lamp and buzzer will be in sync continuously till the state remains TRUE.

INSTRUMENT CLUSTER

S N	Feature	Condition	Reminder
15	Turn Indication Hazard warning ON	If any of the turn indication or both turn signals are ON, tick-tock chime will sound.	Sound will be given to alert User
16	Speed Limit Chime	If speed goes above defined threshold (120 KMPH) Buzzer will sound to alert user, chime sounds continuously till the speed comes down to the normal limit (<80 KMPH).	Sound will be given to alert User
17	Door open, park brake OFF and IGN OFF	If ignition is OFF, park brake not engaged and door is open.	Sound will be given for 15 sec to indicate the user that to engage the Park Brake before leaving the car.
18	EV Limp Home mode	When SOC percentage crossed the limit then Tell-tale will get activated to indicate EV system with limited performance so that user shall take the necessary safety actions.	Buzzer will start along with the warning lamp blinking to indicate the user to contact TATA MOTORS EV Authorised Service Centre. Warning lamp and buzzer will be in sync continuously till the state remains TRUE.

STARTING AND DRIVING

BEFORE YOU START YOUR EV

- Make sure that the area around the vehicle is clear.
- Do a check of the fluid levels coolant, brake fluid, and windshield washer fluid as frequently as possible.
- Make sure that all windows and lights are clean.
- Examine the tyres for their appearance, inflation pressure and condition.
- Make sure that all doors are closed.
- Position the seat and adjust the headrests.
- Adjust the inside and outside mirrors.
- Fasten seat belts and ask all passengers to do likewise.

Do a check of the operation of the warning lights when the power switch is pushed to the ON position. For additional information, refer to “Warning lamps and audible reminders” in the “Instrument Cluster” section of this manual.

Procedure to Start EV

1. With the smart key sit in the driver's seat (if equipped)/Engage the key in the lock set.
2. Fasten the seat belt before you start the vehicle.
3. Turn off all electrical devices.
4. Make sure to engage the parking brake for your safety.
5. Make sure to press and hold the brake pedal while pressing the start/stop button.
6. The vehicle will get ON in 'P' mode only and it will be automatically selected.
7. When 'Ready' message appears, you can drive the vehicle. Else, you cannot drive the vehicle. Start the vehicle again.

WARNING

When the 'Ready' message is ON and if the gear is in a position other than N (Neutral), the driver can accidentally press the accelerator pedal, causing the vehicle to move unexpectedly.

8. Shift using shifter to the desired position (D/R). Parking brake will be still engaged.
9. Release the parking brake and slowly release the brake pedal. See if the vehicle slowly moves forward, then press the accelerator pedal.



Procedure to Stop EV

1. Hold down the brake pedal until the vehicle comes to halt.
2. Continue to press the brake pedal, first shift to N mode and further shift to P mode/engage parking brake.
3. Press the start/stop button to OFF position to stop the vehicle.

STARTING AND DRIVING

Range of Your EV

Your EV can drive as per given range in below table, when the high voltage battery is 100 per cent charged. However, in certain situations like driving at high speed or when the air conditioner/heater is ON, the distance to empty can reduce significantly, as the high voltage battery consumes more electricity.

S.N	Range	Battery state
1	Option I- 502 km* (P1), 430 Km (P1+P2)	100%
2	Option II- 585 km* (P1), 502 Km (P1+P2)	100%

P1 Cycle -Modified Indian Driving Cycle (max speed 50kmph)

P1+P2 Cycle - Urban and Extra- Urban Driving Cycle (max speed 90kmph)

* Range mentioned under standard test condition.



If the “—” symbol is displayed, charge the vehicle immediately. After you charge

your vehicle, the distance to empty reading may vary significantly depending on previous operating patterns. When previous driving patterns include high speed driving, resulting in the driving battery using more electricity than usual, the estimated distance to empty is reduced.

When the high voltage battery uses a little electricity in ECO mode, the estimated distance to empty increases. Distance to empty may depend on many factors such as the charge available in the high voltage battery, weather, and temperature, durability of the battery, geographical features, and driving style. Natural degradation may occur with the high voltage battery depending on the number of years the vehicle is used. This may reduce the distance to empty. Contact your nearest TATA MOTORS EV Authorised Service Centre to replace the battery in that case.

*i*NOTE

Any additional load in the car drains the battery or it may effect on range of vehicle.

ELECTRIC POWER ASSISTED STEERING (EPAS)

Your vehicle is equipped with electric power assisted steering system. The EPAS system makes steering the vehicle easier with less effort.

In EPAS system, the steering effort becomes heavier as the vehicle speed increases and becomes lighter as the vehicle speed decreases for better control of the vehicle at different vehicle speeds.

If the vehicle is 'OFF' or if the EPAS system becomes inoperative, the vehicle still can be steered with more steering effort.

This EPAS system is available with the following assist features

1. Speed sensitive assist control
2. Active return control

*i*NOTE

- A click noise may be heard from the EPAS relay after the ignition switch is turned ON or OFF position.
- The steering wheel may not unlock normally in some cases when ISS

button pressed. If this happens, turn the steering wheel to the right or left slightly to unlock the steering wheel while pressing ISS button.

WARNING

In case of below malfunction conditions, then, take your vehicle to the nearest TATA MOTORS EV Authorised Service Centre and have the EPAS system checked as soon as possible.

- Vehicle noise may be heard when the vehicle is driven at low speeds.
- If the EPAS system does not operate normally, the warning light  will illuminate on the instrument cluster. The steering wheel rotation may become difficult to control or operate.

NOTE

- The steering effort can suddenly increase, if the operation of the EPAS system is stopped to prevent serious accidents when it detects malfunction of the EPAS system during self-diagnosis.
- When steering for a prolonged period, the steering effort will increase to prevent overheating and damage to the steering system.

STARTING AND DRIVING

STEERING LOCK / UNLOCK AND IGNITION SWITCH

Steering Lock / Unlock

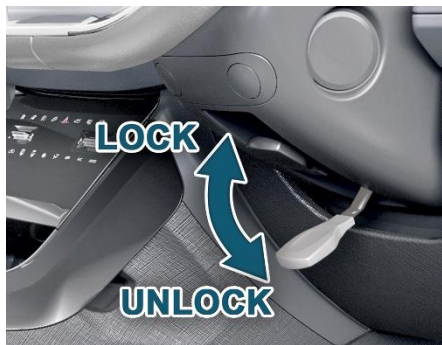

To adjust the steering wheel

1. Adjust the seat to a comfortable position.
2. Push the tilt lever completely down to unlock the steering column.
3. Adjust the steering wheel to the desired position.
4. Pull the tilt lever up completely to lock the steering column.

5. Make sure that steering wheel is securely locked by checking up and down direction.

NOTE

When adjusting the steering wheel, make sure that:

- You can see control pedals without any obstacles.
- You can see all the displays in the instrument cluster clearly.

WARNING

Before you start the car, make sure the steering wheel position is locked. Do not unlock or adjust the steering wheel while the vehicle is in motion.

Start /Stop switch (if equipped)



Single press start/stop switch will bring the vehicle to the ACC ON condition (Amber color)

Second press will bring the vehicle to the ignition ON condition (Green color). To start the vehicle press the brake pedal and press the start/stop switch again.

Press the start stop switch again to switch OFF the vehicle.

With EPAS it gets automatically locked and unlocked as the ignition switch is OFF/ON.

NOTE

- If smart key is inside the vehicle and on pressing start stop switch, if start stop switch green LED blinks more than 10 sec. duration then contact TATA MOTORS Authorised Service centre.
- If ESCL (Electronic Column Steering Lock) is not unlocked properly, then vehicle doesn't go into ACC mode.

Backup Start

To start the vehicle when smart key battery voltage is low, the user needs to press start/stop switch two times with an interval of 2.5 seconds after pressing the brake with valid smart key near immobilizer antenna (in Centre Console).

NOTE

If ESCL (Electronic Column Steering Lock) is not unlocked properly, then vehicle will not get started.

Vehicle Passive Start - Conditions Single Press Start

1. Bring the smart key with you and sit in the driver seat.
2. Press the brake pedal and then press the start/stop switch.
3. Green colour LED on start/stop button will turn ON.
4. Once vehicle is started successfully, the green colour LED on start/stop button stays ON.

Two Step Start

Step 1

1. Have the smart key with you and sit on the driver's seat.
2. Press the start/stop button without pressing brake pedal.
3. Amber colour LED on start/stop switch turns ON.
4. Vehicle will remain OFF and all electrical equipment and infotainment system can be used. Steering is unlocked

Step 2

1. Press the brake pedal and then press start/stop button to start the vehicle.
2. Green colour LED on start/stop button will turn ON.
3. Once vehicle start successfully, green colour LED on start/stop switch will remain ON.

Three Step Start

Step 1

1. Have the smart key with you and sit on the driver's seat.
2. Press the start/stop button without pressing brake pedal.
3. Amber colour LED on start/stop button will turn ON.
4. Limited information will be displayed on instrument cluster and steering will be unlocked. Vehicle remains OFF.

Step 2

1. Press the start/stop button without pressing brake pedal again.

STARTING AND DRIVING

- Green colour LED on start/stop button will turn ON.
 - Vehicle will remain OFF but all electrical equipment and infotainment system can be used.
- Amber color LED on start/stop switch turns ON.

WARNING

When vehicle is in OFF mode, if user tries to lock the vehicle from outside by pressing door handle switch and PEPS detects that the smart key is left inside the vehicle, an audio warning/chime is sounded and doors will not get locked.

Step 3

- Press the brake pedal and then press start/stop button to start the vehicle.
- Green colour LED on start/stop button will turn ON.
- Once the vehicle is started successfully, the green colour LED on start/stop button stays ON.

Vehicle Passive Stop - Stationary Conditions

Single Press Stop

- Press the start/stop button with or without brake.
- ACC and IGN turns OFF.
- LED on start/stop switch turns OFF.

Single Long Press Stop

- Press the start/stop button for more than three seconds.
- IGN returns OFF, ACC remains ON.

DRIVING TIPS

- Plan your tour in advance get help from google maps, check for road conditions, kms to be covered in a day, halting destination, fuel station, food station, hospitals and roadside assistance in case of emergency.
- Always wear your seat belt and ensure all passengers so the same.
- Follow speed limits and adjust your speed according to road condition.
- Keep safe following distance from the vehicle in front of you.
- Obey traffic rules and sign at all times.
- Avoid distraction like mobile phone, texting while driving.
- Check your mirror frequently and be aware of surrounding.
- Never drive under the influence of alcohol or drugs.
- Avoid aggressive driving behaviour like tailgating or excessive over speeding.

- Regularly maintain your vehicle to ensure good working condition.
- Take adequate break and rest every after 200 kms.
- Check tyre pressure, coolant, oil indication, any leakage under the vehicle regularly during travelling.
- Use horn, light and indicators as per condition.

WARNING

We strongly advise you not to drive in late hours/sleep hours to avoid fatality because body response is slow to respond to any situation in this time period.

NOTE

Remember, safe driving is crucial for your safety and safety of others on the road, drive responsibly following above driving tip may help is good and enjoyable travelling experience.

Driving Through Water/ Flooded Water

- Drive through calm water only if it is not deeper than 300mm and at this depth, the vehicle speed to be maintained at creep speed.
- If car gets completely or partially submerged in water, switch OFF the ignition, evacuate the car and call RSA (Roadside Assistance) at 18002098282 for assistance
- We do not recommend you to drive through flooded water as it may enter the vehicle interior and motor compartment which could damage power electronic, electronic & electrical systems. Judge the depth of water before driving through it.

WARNING

If vehicle is flooded with water, do not attempt to start the vehicle. Tow the vehicle to a safe place. Contact a nearest TATA MOTORS EV Authorised Service Centre.

STARTING AND DRIVING

Driving on a Wet Road

Check wiper blades, lights and brakes for proper functioning and condition. Check the tyre treads depth, the condition of the tread and tyre. Avoid harsh braking and sharp turns. It may cause loss of control and lead to skid. Keep lights 'ON' if visibility is poor.

WARNING

On wet road or during light showers, "Aquaplaning" can occur. "Aquaplaning" is the loss of direct contact between the road surface and the vehicle's tyres due to a water film forming between them. Steering or braking the vehicle can be very difficult, and loss of control can occur.

There is no hard and fast rule about aquaplaning. The best advice is to slow down when the road is wet.

NOTE

If you have driven for a long time in heavy rain without braking, there may be a delayed reaction from the brakes when braking for the first time. You have to press the brake pedal more firmly. Maintain a greater distance from the vehicle in front.

Driving on snowy roads

While driving on snow, it is advisable to use the snow chain on roads. Follow assembly and safety instruction provided by the snow chain manufacturers.

WARNING

Wet ice (0°C and freezing rain), snow or ice can be slick and very hard to drive on. The vehicle will have much less traction or "grip" under these conditions. Try to avoid driving on wet ice until the road is salted or sanded.

- Whatever the conditions, drive with caution. Accelerate and slow down with care. If accelerating too fast, the drive wheels will lose even more traction.

- Allow more stopping distance under these conditions. Braking should be started sooner than on dry pavement.
- Allow greater following distances on slippery roads.
- Watch for slippery spots (glare ice).
- These may appear on an otherwise clear road in shaded areas. If a patch of ice is seen ahead, brake before reaching it. Try not to brake while on the ice, and avoid any sudden steering maneuvers.
- Do not use cruise control on slippery roads.

Driving at Night

- Ensure that all lights are working and windshield, window glasses are clean.
- Drive more slowly at night than in the daytime, as the visual range is restricted at night. Maintain a speed such that you can stop within illuminated distance of headlamps.

- Do not use the high beam unless inevitable. It may dazzle the driver of the oncoming vehicle, thus causing an accident.
- Use headlamp main/dip beam to alert other road users on turns/ cross roads etc.
- Use side indicators for lane change or turning.

Driving on Gradients

When climbing gradient, plan it in advance so that the vehicle speed is maintained.

When driving down a hill, the regenerative braking should be used. Do not switch OFF the vehicle.

WARNING

On long and steep gradients you must reduce the load on the brakes by taking your foot off the accelerator pedal. This allows you to take advantage of regenerative braking effect and helps avoid overheating of service brakes resulting in reduced braking efficiency.

Driving in Heat and cold weather

The heating and cooling on the car uses energy from the battery. Set temperatures to a comfortable 24° C - 26° C with Auto mode and Econ activated, and see the comfort as well as the range go up significantly

CAUTION

Do not park the vehicle in temperatures below -22°C for more than seven days. If the outside temperature is -22°C or less, the Li-ion battery may freeze and it cannot be charged or provide power to run the vehicle. Move the vehicle to a warm location

Driving on Highway

Do not change the accelerator pedal inputs rapidly. Go as smooth as possible. EV's being instantaneous torque and power – there is very little lag in translating the pedal input to vehicle response.

Stopping distance progressively, increases with vehicle speed. Maintain a

sufficient distance between your vehicle and the vehicle ahead.

For long distance driving, perform safety checks before starting a trip and take rest at certain intervals to prevent fatigue.

EV's give best range between speeds of 40 – 60 kmph. Therefore they are ideal for city applications. Driving in this range along with following of other points here will add your mileage significantly. A driving speed band of 60 to 80 kmph is recommended on highway. At high speed, the range may result in significant drop in range.

STARTING AND DRIVING

TIPS TO GET MAXIMUM RANGE WHILE DRIVING EV

Acceleration, Braking and Coasting

Acceleration: This vehicle has a single speed automated gearbox. In accelerating mode, the torque supplied by the motor via the gearbox to the front wheels is linear in nature.

1. Regenerative Braking

- This vehicle is equipped with a regenerative brake system. The primary purpose of the regenerative brake system is to provide some power to help recharge the Li-ion battery and extend driving range.
- The electric motor when decelerating and braking and transforms kinetic energy to electrical energy in order to charge the high voltage battery. (Torque is applied in the

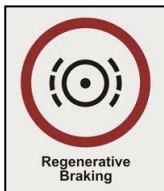

opposite direction when decelerating to generate braking force and electricity).

- A secondary benefit is an effect similar to “vehicle braking” seen in IC vehicle cars. Here, it depends on HV battery condition.
- In the Drive mode, when the accelerator is released, the regenerative brake system provides some deceleration and generates power for the high voltage battery.
- Power is also generated when the brake pedal is applied.
- The calibration on the regen is done in such a way that most people can experience a “single pedal” drive at most times, just lift your feet of the accelerator pedal to slow the vehicle down and gain range. Brake lightly if required
- When you brake and take your foot off the accelerator pedal, more regenerative brake is applied than in the drive mode. However, during high-speed driving you may feel

that regenerative brake provides less deceleration than the motor braking in an ordinary vehicle. This is normal.

- Less deceleration is provided by the regenerative brake system when the Li-ion battery is fully charged. Regenerative brake is automatically reduced when the high voltage battery is fully charged to prevent it from overcharging.
- Regenerative brake is also automatically reduced when the battery temperature is high/low to prevent battery damage.
- The brake pedal should be used to slow or stop the vehicle depending on traffic or road conditions. The vehicle brakes are not affected by regenerative brake system operation.
- Use correct Regen Selection for better range.

It is recommended to use below mention Regen level for better mileage:

- Regen level “0” or “1” in case of plain highway.
- Regen Level “1” & “2” In city drive with normal traffic.
- Regen Level “2” & “3” In city drive with heavy traffic.

2. Interior Climate

Heating and Air conditioning system uses energy from the high voltage battery and this reduces range. For maximizing range during air-conditioning on driving, it is recommended to set the air conditioning in Auto mode with Econ activated. Also the set temperature should be set between 24-26 deg C. EV is equipped with Remote Air conditioning. You can remotely start Air Conditioning system. However, this also consumes energy from the high voltage battery and reduces the driving range.



3. Driving Speeds

At high speeds, greater than 80kmph, high amount of energy is spent in propelling the vehicle and hence reduces range. Similarly, idling for long duration also reduces range significantly.



4. Driving Style

Driving behavior has a significant influence on the driving range of an electric vehicle. Frequent and heavy accelerations will have a detrimental impact on car's driving range whereas travelling at a steady pace, in between 40-80 km/hr will help an electric car to maximize range. Predictive driving with gradual acceleration reduces your reliance on hard braking. This helps conserve energy during acceleration and regenerate optimally during deceleration.



However, brake should be applied as necessary to avoid hazards to occupants and surrounding.

5. Tyre Pressure

Maintaining specified Tyre pressure only ensures comfortable ride comfort but also maximizes range by minimizing rolling losses of the vehicle. It is advisable to regularly monitor and maintain the tyre pressure within specified limits.

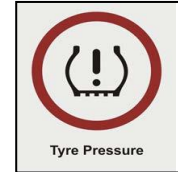

6. Unauthorized Electrical Accessories

Unauthorized aftermarket electrical accessories can potentially consume higher energy than factory fitted ones and may affect range directly. They can also lead to functional complications and lower component life in the long run. It is recommended to fit only



STARTING AND DRIVING

TATA Genuine Accessories at Authorized EV Service stations.

7. Vehicle Maintenance

Vehicle to be serviced regularly as per service schedule in authorized service stations. It helps in maximizing vehicle performance and component life.



8. Battery Charging

For every 4 consecutive fast charges, 1 complete slow charge is recommended (<20% to 100% SoC) to ensure consistent performance and better health of the high voltage battery. This improves charge balancing during charging and deliver better driving range.

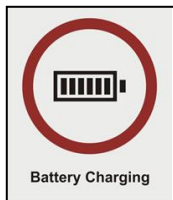

9. Dead Weight

Dead weight like bags, boxes etc. which is not required should be removed from the car. This lowers the energy required to propel the vehicle and improves driving range.



Limp Home Strategy

Soc Intervention					
Zone	IPC message and state	Max speed	Acceleration	Gradability	Cabin cooling
SoC <=25%	If the vehicle is in Sport mode, it will automatically shift to Drive mode which will be shown on cluster	No change	No change	29%	No change
SoC <=10%	Then SoC Gauge 1 st Bar ON with single chime and low charge, Limp Home Tell-tale will be ON & “RECHAGE” will display	50 kmph	Reduced	18%	No cooling
SoC <=5%	SoC Gauge 1st Bar will Blink along with Low Charger tell-tale with continuous chime	50 kmph	Reduced	18%	No cooling

Fault Intervention					
S. N.	Telltale Indication	Max. Speed	Acceleration	Gradability	Cabin Cooling
1	HV critical ON + Single Chime. Limp home Telltale blinking	50 kmph	Reduced	20%	No change
2	Limp home Telltale blinking + single chime	50 kmph	Reduced	20%	No change

STARTING AND DRIVING



Limp Home Condition of EV

In situations when certain conditions in the vehicle are not met or when some fault arises in the vehicle, the vehicle control unit intervenes and puts the vehicle into Limp Home Mode. The vehicle will give reduced performance in these situations. These limp home interventions are defined on two levels which are provided in the table.

NOTE

There will be a single audio chime whenever the vehicle goes into Limp Home Intervention along with the IPC message. Sports mode cannot be selected if the vehicle SoC is below 25% or the vehicle is in limp home mode. If the vehicle is already in sports mode, it will automatically switch to drive mode. A message 'Shifter not allowed' will be displayed with an audio warning. When level 1 intervention takes place, the vehicle will not start in the next ignition cycle

Limp Home Mode Telltale Warnings

Tell tale Indicator	Condition	Description
	Blinking	HV Critical Fault Contact TATA MOTORS EV Authorised Service Centre.
	Continuously ON	HV Critical Fault Mobility is not allowed Contact TATA MOTORS EV Authorised Service Centre.
	Continuously ON	Vehicle has entered in Limp Home mode



DRIVE AND SHIFTER MODES

Drive Modes (if equipped)



Drive mode selection switch 'ECO', 'CITY' and 'SPORT' drive modes are provided. These modes can be used to adjust motor torque characteristics and vehicle performance in line with desired requirement.

Drive mode selection switch is provided on center console for activation.

Drive Mode	Performance
 CITY	Increased Motor Torque and Power output for BALANCED performance.
 ECO	Optimum Motor Torque and Power output for EFFICIENT performance.
 SPORT	Driver can use maximum torque from Motor.

Shifter Modes (if equipped)



Neutral (N)

The mono shifter is in 'N' mode position and 'N' will be indicated in Instrument Cluster.

Drive (D)

The mono shifter is in 'D' mode position and 'D' will be indicated in Instrument Cluster.

Park (P)

The mono shifter is in 'P' mode position and 'P' will be indicated in Instrument

STARTING AND DRIVING

Cluster. When starting the vehicle or parking the vehicle. Apply the parking brake whenever the vehicle is to be parked.

Reverse (R)

The shifter knob is in 'R' shifter position and 'R' will be indicated in Instrument Cluster.

Mono-stable Shifter

- Your vehicle is equipped with Mono stable shifter, where the shift lever returns to its stable position the moment it is released.
- It is provided with 2 UP positions and 2 DOWN positions: UP2-UP1-Stable-DOWN1-DOWN2.
- The user shall release the shifter after each shift, as any new shift will be possible from stable position only.
- The user has to confirm the desired shift position on display.
- Shifter shall not be attempted from non-stable position by continuously holding the shifter in the previous shift position.

Gear shift Position		Mono-stable shifter movement	Unlock Button Press	Brake Pedal Press
UP2	P to R	Stable position -> Up2 (2nd detent)	Yes	Yes
	D to R	Stable position -> Up2 (2nd detent)	Yes	Yes
	P to N	Stable position -> Up1 (1st detent)	Yes	Yes
UP1	N to R	Stable position -> Up1/Up2	Yes	Yes
	D to N	Stable position -> Up1 (1st detent)	Yes	No
Stable Position				
Down 1	P to D	Stable position -> Down1/Down2	Yes	Yes
	R to N	Stable position -> Down1(1st detent)	No	No
	R to D	Stable position -> Down2(2nd detent)	Yes	Yes
Down 2	N to D	Stable position -> Down1/Down2	Yes	Yes

STARTING AND DRIVING

OPERATING OF LIGHTS AND WIPERS

Combi-switch (RH Stalk)

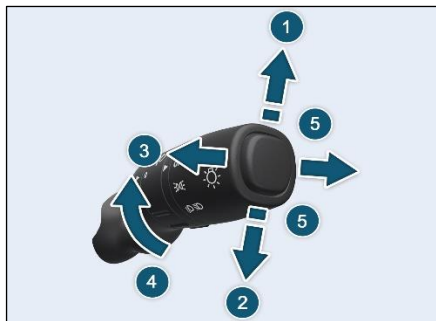

1. Left Turn Signal

Move the lever fully upward.

2. Right Turn Signal

Move the lever fully downward.

iNOTE

When the turn is completed, the signal will cancel and the lever will return to its normal position.

3. High Beam Flash (Spring Return)

To flash the high beam, pull the lever towards you from the normal position. It will return to its normal position when you release it.

4. Headlamp Rotary Switch

Auto Light (if equipped)



The headlights will be automatically switched ON depending on ambient light conditions (while entering a tunnel or when it is twilight).

OFF Position



All lamps will remain 'OFF.'

Parking Lamp



Rotate stalk to turn 'ON' the Parking lamps.

Day Time Running Lamps (DRL) (if equipped)



Day time Running Lamps (DRL) are used to increase the visibility of the vehicle to other drivers during daytime.

DRL is activated when ignition switch is 'ON' and to deactivate, switch the parking lamp ON-OFF twice within approx. three seconds.

Deactivation of DRL can be done by DRL soft switch, which is available on the Head Unit Display.

Low Beam



Rotate stalk to turn 'ON' the Low Beam function.

High Beam

Move the lever forward to select the high beam function. Pull the lever back to normal for low beam.

5. Lane Change Signal (if equipped)

To signal a lane change, move the lever slightly up or down to the point where the turn signal light begins to flash, but the lever does not latch. The turn signal will flash six times automatically.

Head Lamp Leveling Rotary Switch

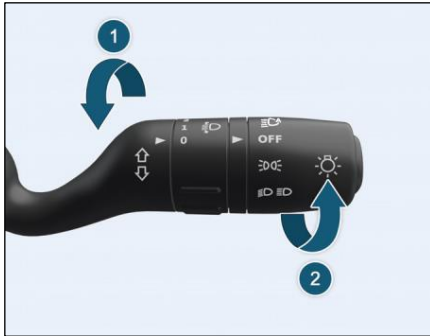

Inner rotary switch on right hand stalk is provided for head lamp leveling. With the inner rotary switch, Head lamp leveling can be done with head lamp in Low Beam and in 'ON' position. Select correct position before start of trip, when the vehicle

is stationary. Depending on the number of passengers and luggage in the vehicle headlamp focus may change. This can be adjusted by rotating the knob to one of the three level positions.

Combi-switch (LH Stalk)

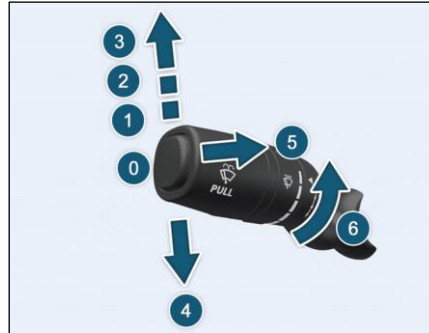

OFF" Position

The wiper is switched 'OFF'.

Intermittent Wipe

Push the stalk upwards to operate intermittent wipe.

Inner rotary switch on left



hand stalk is provided for intermittent front wiper delay. The switch has five delay timers.

Slow Wipe

Push the stalk towards position (2) for continuous slow wipe.

Fast Wipe

Push the stalk towards position (3) for continuous slow wipe.

Flick Wipe (Spring Return)

Pull the stalk downwards and hold it for continuous wipe, the wiper continuously wipes across the windshield at low speed till the stalk is released.



Front Windshield Washer

- Pull the lever little longer, to spray the washer fluid on the windshield.
- The windshield wipers will operate for three cycles after the lever is released and for one more cycle after five seconds.

STARTING AND DRIVING

Manual Mode

- Pull the lever little longer, to spray the washer fluid on the windshield.
- The windshield wipers will operate for three cycles after the lever is released and for one more cycle after five seconds.

Auto Mode (if equipped)

If your vehicle is fitted with rain sensor, the wipers will automatically wipe the windscreen, if it senses rainfall. Make sure that the wiper stalk is in Auto position.

iNOTE

When you start the vehicle, the supply to washer motor is momentarily cut off.

Rain/light Sensor (if equipped)

The integrated rain and light sensor is mounted on front windshield glass to sense rain and light. As per the input from sensor, the wipe and light functions will work automatically.

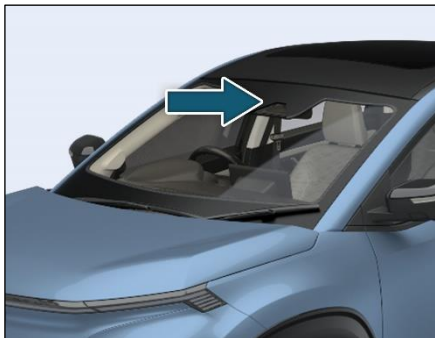

Horn



Horn is located on steering wheel. Use it whenever required.

WARNING

Check out for No Horn zone, where use of horn is prohibited.

SEATS ADJUSTMENTS

Front Row Seats Adjustments

Driver Seat Manual Adjustments (if equipped)



Following seat adjustments can be carried out manually.

1. Driver Seat Backrest Angle Adjustment
2. Driver Seat height adjustment
3. Driver Seat forward/backward adjustment lever

WARNING

Do not adjust the driver's seat while driving. Adjusting the seat while driving could cause the driver to lose control of the vehicle.

1. Driver Seat Backrest Angle Adjustment

To change the seat back rest angle, lean forward slightly and pull up the lever (1). Adjust seat backrest until it reaches desired comfortable position. Make sure that lever returns to its original position and seat is securely latched.

NOTE

Adjust the seat backrest until your arms are slightly angled when holding the steering wheel.

WARNING

Never travel in a moving vehicle with the seat backrest in an excessively reclined position as this can be dangerous.

You could slide under the seat belt in a collision.

2. Driver Seat height adjustment

To raise the seat, pull and continue pumping the lever (2) in the upward direction until the seat is at the desired height. To lower the seat, pump the lever downward until the seat is at desired height.

3. Driver forward / backward adjustment

Lift lever (3) and slide the seat forwards or rearwards. Release lever and make sure that seat is securely latched.

NOTE

Adjust the driver seat position in such a way that the driver will be able to operate the control pedals conformably.

STARTING AND DRIVING

Co-driver Seat Adjustments (if equipped)



1. Seat forward/backward adjustment lever
2. Seat Backrest Angle Adjustment
3. Seat height adjustment

1. **Forward / backward adjustment**

Lift lever (1) and slide the seat forwards or rearwards. Release lever and make sure that seat is securely latched.

2. **Seat Backrest Angle Adjustment**

Similar to driver seat, to change the seat back rest angle, lean forward slightly and pull up the lever (2). Adjust seat backrest until it reaches desired comfortable position. Make sure that lever returns to its original position and seat is securely latched.

3. **Seat height adjustment**

To raise the seat, pull the button slightly (3) in the upward direction as per arrow mark, until the seat is at the desired height. To lower the seat, push the button downward until the seat is at desired height.

Front Power Seats Adjustments (if equipped)

Driver Seat



1. Seat Backrest Angle Adjustment
2. Seat height adjustment
3. Forward / backward adjustment

1. **Seat Backrest Angle Adjustment**

To change the seat back rest angle, lean forward slightly and operate the button slightly(1) as per arrow mark either forward or rearward as required. Adjust seat backrest until it reaches desired comfortable position and then release the button.

*i*NOTE

Adjust the seat backrest until your arms are slightly angled when holding the steering wheel.

2. Seat height adjustment

To raise the seat, pull the button slightly (2) in the upward direction as per arrow mark, until the seat is at the desired height. To lower the seat, push the button downward until the seat is at desired height.

3. Forward / backward adjustment

To move seat forward push the button(3) slightly forward as per the arrow mark, to move seat rearward pull the button in rearward direction make sure that seat is securely latched.

*i*NOTE

- *Adjust the driver seat position in such a way that the driver will be able to operate the control pedals comfortably.*
- *Avoid unnecessary operation of*

power seat adjustment buttons as it consumes power from vehicle battery.

- *Do not operate more than one operation button simultaneously.*

Seat Ventilation

To start ventilation, press button once.



It has 3 ventilation adjustment in decreasing order and LED glows for each press. To stop the ventilation long press the button for few seconds.

Default setting is highest speed on first press.

The ventilated seat by default is set to OFF whenever the vehicle START/STOP button is turned ON.

STARTING AND DRIVING



i NOTE

Do not apply excessive force on ventilation button as it may get damaged. Button operates with slight finger force as they are electronically controlled.

To protect ventilated seats-

- Use the air ventilation seat **ONLY** when the vehicle HVAC system is on.
- Never use a liquids like alcohol, high viscosity oils or other to spill on ventilated seats.
- Avoid spillage of liquids on the ventilated seats surface this may lead to blockage of ventilated seat system and may not function properly.
- Do not add seat covers, as it will not allow ventilated seats to function properly.
- Do not keep plastic covers of seat as it is, as it will not allow ventilated seats to function properly.

i NOTE

Ventilated seats to be vacuum cleaned regularly as there are chances of air vent hole blockage after usage.

Rear Seats Adjustments with Recline (If equipped)

Seats Adjustment



Following seat adjustments can be carried out manually.

1. Seat Backrest Angle Adjustment
2. Seat Armrest Adjustment

1. Seat Backrest Angle Adjustment

To change the seat back rest angle, lean forward slightly and pull backrest release knob (1). Adjust seat backrest until it reaches desired comfortable position.

Make sure that lever returns to its original position and seat is securely latched.

2. Seat Armrest Adjustment

A foldable arm rest (2) is available in seat. When not required, fold the armrest back into the seat

Seats Folding (60 - 40% Split Seat) (If equipped)

You can increase the luggage capacity by folding the respective rear seats as required.



To fold the seat:

Pull the backrest release knob to fold the seat forward. (Right side rear seat).



Lift the seat as shown in the figure.



STARTING AND DRIVING

Fold the backseat as shown in the figure.



iNOTE

Ensure that 'foldable arm rest' is close before seat folding.

Follow the same procedure for driver side seat.



Seats Folding (100%) (If equipped)

Pull the backrest release knob provided on both side simultaneously.



Lift the seat as shown in the figure.



Fold the backseat as shown in the figure.



WARNING

- You should always engage the rear seat if you do not need the through loading feature.
- If the rear bench seat and seat backrest are not engaged they could fold forwards, e.g. when braking suddenly or in the event of an accident.
- The vehicle occupant would thereby be pushed into the seat belt by the rear bench seat or by

the seat backrest. The seat belt can no longer offer the intended level of protection and could even cause injuries.

- Objects or loads in the trunk cannot be restrained by the seat backrest. There is an increased risk of injury.
- Before every trip, make sure that the seat backrests and the rear bench seat/rear seat are engaged and securely latched.

STARTING AND DRIVING

MIRRORS

Inside Rear View Mirrors (IRVM)



To adjust the mirror move the mirror up, down or sideways manually to obtain the best rear view.

When you drive at night, set the selector tab to select anti-glare mode (if equipped) to reduce glare from the headlights of vehicles behind you.

*i*NOTE

Use antiglare position only when necessary, as it reduces rear view clarity.

Automatic Dimming IRVM (if equipped)



1. Photocell Sensors
2. ON/OFF button

Automatic dimming rear view mirror automatically controls the glare from the headlights of the car behind you in night time or low light driving conditions. Press ON/OFF button to turn ON the automatic dimming function.

The LED indicator on the IRVM shows the active status of auto dimming function. The auto dimming IRVM is defaults to the

ON position whenever the ignition switch is turned ON and it is switched OFF whenever reverse gear is engaged.

*i*NOTE

For proper operation, keep the photocell sensors clean and do not cover the area between the IRVM and the windshield.

Outer Rear View Mirrors (ORVM)

Motorized ORVM Adjustment (if equipped)

The switch to adjust the motorized mirrors is located on the driver's door. You can adjust the mirrors when the ignition switch is in the "ACC" or "ON" position.



To adjust the Mirror

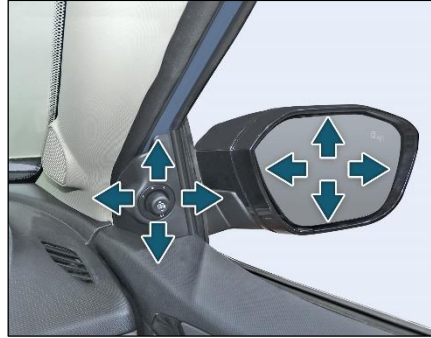

1. Move the mirror selection switch to L (for left side) and R (for right side) to select the mirror you wish to adjust.
2. Use the four positions of the knob to adjust the rear view mirrors to required position.

ORVM Folding

Option 1: Auto folding by Smart Key (if equipped)

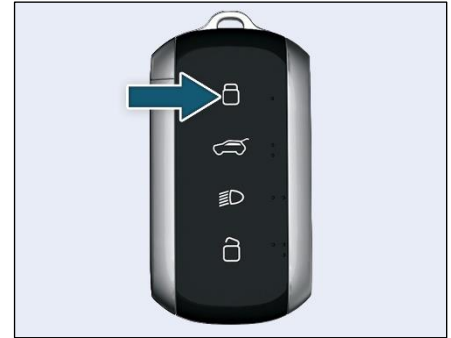

When you lock the vehicle, ORVMs will be folded automatically.

iNOTE

ORVM auto unfold not work, in case of user select the ORVM auto unfold option disabled through infotainment screen.

STARTING AND DRIVING

Option 2: Auto Folding by Knob

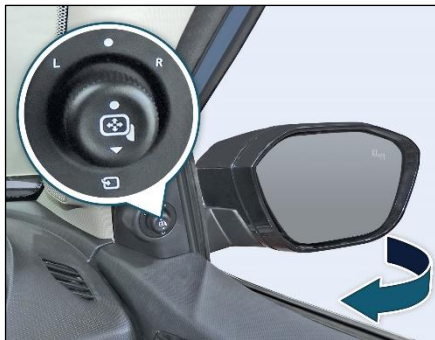

To fold / unfold the ORVMs, keep the Selector switch in center position (i.e. neither 'L' nor 'R, position) and then toggle down. This will operate when the ignition switch is in the "ACC" or "ON" position.

Sun Visors

The sun visors can be pulled down to block the glare coming through the windshield. To block the glare from side windows, pull down the sun visor and release it from retainer. Swing the sun visor to the side.

Vanity Mirror (if equipped)

Vanity mirror is provided on the back of the front passenger side sun visor.

DRIVING SUPPORT SYSTEM

Electronic Parking Brake (EPB) (if equipped)



EPB switch is located behind the Mono shift knob EPB is applied by pulling up the EPB switch and can be released by pushing down the EPB switch which needs the vehicle to be at ignition ON condition. Always ensure parking brake is released and parking brake warning lamp is OFF before start of the drive. Park brake warning lamp in cluster at vehicle running condition indicates failure in brake system

needs to be checked with TATA MOTORS EV Authorised Service Centre and vehicle needs extreme precaution until you reach TATA MOTORS EV Authorised Service Centre.

iNOTE

Apply the parking brake properly before leaving the vehicle and release it before moving.

How to Apply

Depress the Brake pedal & Pull EPB switch upward.

iNOTE

Kindly ensure EPB indication turns on in the Cluster. EPB will be applied automatically if vehicle is turned off and Mono shifter is engaged to park position. During parking the vehicle on Steep incline or trailer is attached, kindly ensure EPB can hold the vehicle before leaving.

⚠WARNING

Do not use parking brake in vehicle during running condition except for emergency situations like service brake failure. It will affect the entire brake system. If the EPB fails to apply, prevent vehicle movement by blocking the rear wheels.

How to Release

EPB will be released only if you press the EPB switch along with Ignition is on or vehicle is running. & Brake pedal is depressed.

Kindly ensure parking brake indication in instrument cluster is turned off after EPB is released

EPB Getting Released Automatically

The following steps to be followed for EPB auto release:

1. Vehicle READY condition
2. Driver door closed & seat belt buckled
3. Shifter knob in D/R mode
4. Press ACC pedal to drive away

STARTING AND DRIVING

Surround View System (SVS)

Surround view system displays the surroundings around the vehicle to the driver for safe and comfortable drive.

SVS assists the driver while reversing and maneuvering the vehicle at lower speeds.

Camera Locations as Shown In the Images



Front Camera



Left Side Camera

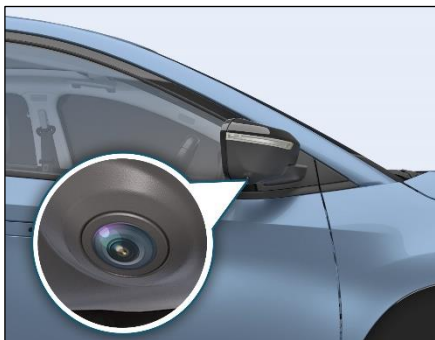

Right Side Camera



Rear Camera

Activation of SVS

The function is activated when:

1. Surround view soft switch is pressed on Fascia switch



2. Surround view soft switch is pressed on Head unit.

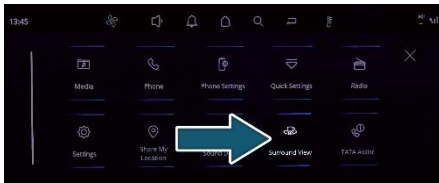

3. The shift lever is in D (Drive), N (Neu-

tral) or R (Reverse) and vehicle speed is under 17 kmph and surround view soft switch is pressed.

4. Shift lever is in Reverse and vehicle speed is below 17 kmph.

Deactivation of SVS

SVS function is deactivated when one of the following step is performed.

1. Surround view soft switch is pressed again
2. Vehicle speed is more than 17 kmph
Disengage the reverse.

NOTE

- When vehicle speed is more than 17 kmph, the SVS function will turn off. The function will not automatically turn on again, even though vehicle speed gets below 17 kmph. Press the switch again, to turn on the function.
- When vehicle speed is more than 17 Kmph SVS screen will be switch to only rear view during reverse.

- During vehicle speed is more than 17 Kmph and driver activate through soft switch/hard switch rear view shall display to user.

STARTING AND DRIVING

Surround View System Features

The Surround view system has the following features

1. 2D View
2. 3D View
3. Front Corner View
4. Rear Corner View
5. Full View
6. Settings
7. Cancel Icon

2D View

By selecting 2D Icon which is available on the right corner side of the infotainment screen, cameras provide about 360 degree 2D top view of vehicle's surrounding.

In 2D top view mode 4 camera icons will be present around the model car image to switch to different sides of view. The different 2D views are as follows.

- I. 2D Top view + Front view
- II. 2D Top view + Rear view
- III. 2D Top view + Left view
- IV. 2D Top view + Right view



2D Top + Front view

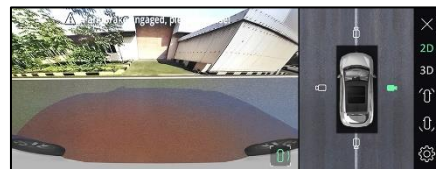

2D Top + Right view



2D Top + Rear view



2D Top + Left view

3D View

By selecting 3D Icon, cameras provide about 360 degree 3D view of vehicle's surrounding on the Infotainment screen

In 3D mode view 8 camera icons will be present around the model car image to switch to different angle of view.

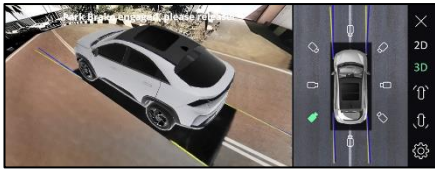

3D view with 8 different views

Front Corner View

If driver wants to focus on the front corner view, then the icon can be pressed to select the view.

By selecting front corner view icon, camera provides a focused view on the front left and right corners to provide a better visibility for safe maneuver.



Front corner view

Rear Corner View

If driver wants to focus on the rear corner view, then the icon can be pressed to select the view.

By selecting rear corner view icon, camera provides a focused view on the rear left and right corners to provide a better visibility for safe maneuver.



Rear corner view

Full View

I. 2D Full front view

By selecting 2D front view Icon which is available on the model car image, cameras provides about wide 2D front view of vehicle's surrounding on the Infotainment screen.

Press full view button to view front objects closer and press the same button to go back to the normal 2D front view.



2D Full Front view

II. 2D Full Rear view

By selecting 2D rear view Icon which is available on the model car image, cameras provides about wide 2D view of vehicle's surrounding on the Infotainment screen.

Press full view button to view rear objects closer and press the same button to go

STARTING AND DRIVING

back to the normal 2D rear view.



2D Full Rear View

III. 2D Full Left view

By selecting 2D left view Icon which is available on the model car image, cameras provides about wide 2D view of vehicle's surrounding on the Infotainment screen.

Press full view button to view left objects closer and press the same button to go back to the normal 2D left view.



2D Full left view

IV. 2D Full Right view

By selecting 2D right view Icon which is available on the model car image, cameras provides about wide 2D view of vehicle's surrounding on the Infotainment screen.

Press full view button to view right objects closer and press the same button to go back to the normal 2D right view.



2D Full Right view

Settings

- By selecting the settings icon available on the infotainment screen, driver can change the settings as required.
- User can change the content settings based on the user choice.

- User can change the front and rear default view to any of the view i.e., either normal view or top view

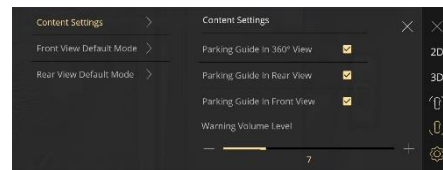

SVS content settings

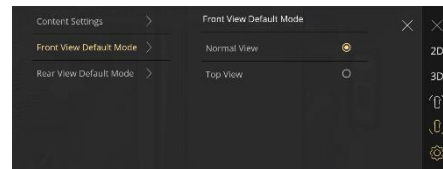

SVS front view default mode settings

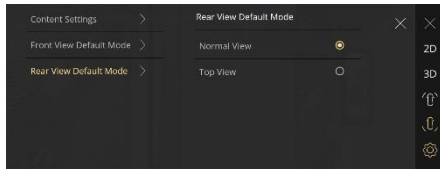

SVS rear view default mode settings

Cancel Icon

By selecting the cancel icon which is available on the top right corner of the infotainment screen, user can exit from the surround view system function.

It can be used for all the SVS features such as 2D, 3D, front & rear corner views.

It cannot be visible when vehicle gear state is reverse.



Understanding Guidelines Indication Static Guidelines



Dynamic Guidelines



Red Line

Indicates, if rear objects are in this colored zone, you have to stop the vehicle and not allowed to go backward. If you still go backward, your vehicle will hit the object.

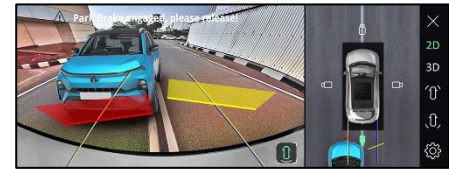

Yellow Line

Indicates, if rear objects are in this colored zone, you have to take utmost care. However, objects fall in this zone, may not hit vehicle.

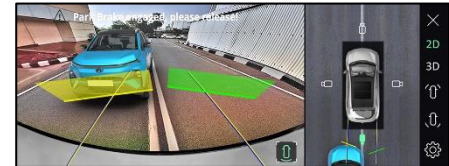

Green Line

Indicates, if rear object is in this colored zone, you have to be cautious. Still you can go backward safely.

STARTING AND DRIVING

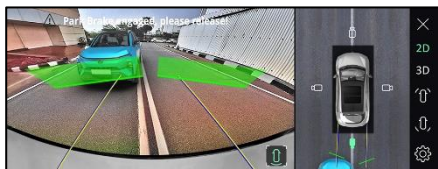

PDC Guidelines Settings

User can change the timer settings for PDC guidelines which is available on the infotainment display .

By selecting the infotainment settings icon available on the infotainment screen user able to open the settings options available in the system

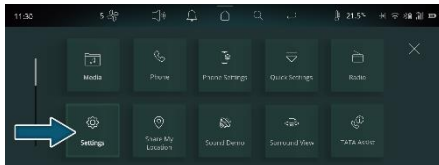

The system will display the below screen when user select the settings icon. Select the driver assistance icon which is available on the screen.



In driver assistance system will provide many other options in that user should select the park assist delay timer. System will provide three different option such as 0sec, 5 sec and 10sec.

Based on the user choice he/she can select any option from the three.



Blind View Monitor

Blind view monitor will helps to reduce the crashes that happens when driver is being overtaken or changing the lanes.

This system should work in ignition on and run condition irrespective of the vehicle speed.

We can enable/disable the blind view monitor in HMI settings based on the user choice.



Activation of Blind View Monitor

- This feature is activated when user turn on the left/right turn indicator.
- On activating the right turn indicator, right side rear view should be displayed on the infotainment along with static overlays.



Right rear side view when turn on the right indicator

- On activating the left turn indicator, left side rear view should be displayed on infotainment along with the static overlays.



Left rear side view when turn on the left indicator

Deactivation of Blind View Monitor

This feature is deactivated when user turn off the left/right turn indicator.

Understanding Static Overlays Indication

Red Line: Indicates, if rear objects are behind this colored line, you are not allowed to change the lane. If you still change the lane, your vehicle will hit the object.

Yellow Line: Indicates, if rear objects are behind this colored line, you have to take utmost care. However, objects fall in this zone, may not hit vehicle.

Green Line: Indicates, if rear object is behind this colored line, you have to be cautious. Still you can safely change the lane.

NOTE

- When SVS is in active condition then user turn on the left/right turn indicator then system should display the blind view monitoring and if user turn off the turn indicator then system return back to the SVS screen.
- When SVS is not in active condition, user turn on the left/right turn indicator then system should display the blind view monitoring. Once user turn off the turn indicator then system return back to infotainment home screen.

Camera Precaution

WARNING

- As the camera is, IP protected, do not detach, disassemble or modify in any manner from the actual position. This will show required visual information in display.
- Do not use camera when tailgate is

STARTING AND DRIVING

open. If tailgate is open, visual information may not be the actual rear view of the vehicle & system will warn with message 'Tail Gate Open, Please close.

- Do not use camera when driver/passenger door is open. If any one of the door is open, visual information may not be the actual view of the vehicle & system will warn with message 'Door Open, Please close'. And also corresponding door side display shall be in dark image.
- Do not use camera when ORVM is folded. If ORVM is folded, visual information may not be the actual view of the vehicle & system will warn with message 'ORVM Folded'.
- When the camera is operated under fluorescent lights, sodium light or mercury light etc., illuminated areas on the lens may appear to flicker in the display.

- Do not attach any advertisement or styling or any kind of stickers on top of camera. If this happens, camera cannot provide you the visual image and may damage camera.
- Do not add any accessory, which will obstruct camera field of view.

Cleaning Camera

1. Due to environmental reasons, dust, mud or fog may accumulate on the camera lens. So regularly clean the camera lens.
2. Use water to clean the camera lens. Do not use extreme cold or hot water. Rapid changes in temperature may brittle the camera lens. Do not apply High Pressure water for cleaning.
3. Wipe the camera lens with soft cloth.
4. Do not use hard cloth or material to wipe the camera lens. This will cause scratches on the camera, and leads to deteriorated visual image on the display.

5. Do not apply organic solvent, car wax, window cleaner or glass coat to clean the camera. If this is applied, wipe it off as soon as possible.
6. Do not use chemical solvents such as strong detergents containing high alkaline or volatile organic solvents (gasoline, acetone etc). This may damage the camera lens
7. Do not apply heavy force on lens, while cleaning.
8. Do not remove mud, snow on the camera lens using stick or hard material. Use normal water and soft cloth.

WARNING

- The camera uses fish eye lens. So the size of the objects or in the display may differ from the actual size and distances in low light conditions, the screen may darken or image may appear faint.
- If the tire sizes are changed, the position of the fixed guidelines displayed on the screen may change

STARTING AND DRIVING

During rainy conditions, image may get obscured. In such conditions, do not depend on camera view.

- The camera used in the vehicle, may not reproduce the same color of the real object.
- Do not apply any kind of force on the camera.
- High humidity and variation in ambient temperature may result into condensation inside the camera lens, which may further result into degradation of camera video feed on the screen. It is recommended that not to rely on camera video feed for parking assistance in such scenario. This phenomenon is temporary and will be automatically recovered with reduction in humidity and less variation in ambient temperature.
- The area displayed by the camera is limited. The camera does not display objects that are close to or below the bumper, underneath the vehicle, or objects out of the camera's

field of view. The area displayed on the screen may vary according to vehicle orientation or road conditions.

Rear View Camera



Rear View Camera is a visual reverse guiding system. When reversing or parking, make sure that there are no persons, animals or objects in the area where you are reversing.

The display will be shown on the infotainment screen.

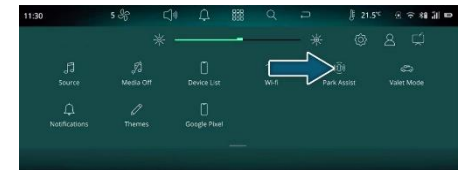

STARTING AND DRIVING



Activation

Reverse

This system will start, if mono-shifter at reverse, or park assist button (if equipped) is pressed or manual activation is done through Infotainment screen.

Deactivation

System will stop, if reverse gear is disengaged, or park assist button (if equipped) is pressed. If started through infotainment, the system can be stopped using a cross button on infotainment screen.

Understanding Guidelines Indication



Static guidelines



Dynamic guidelines

Green Line

You can safely reverse the vehicle, but be cautious if objects fall in this zone.

Yellow Line

You have to take utmost care if objects fall in this zone. However, the objects may not hit vehicle.

Red Line

Red line indicates that you have to stop reversing the vehicle. If you still go backwards, the car will hit the obstacle.

Do's and Don'ts

- Do not use camera when tailgate is open. If tailgate is open, visual information may not be the actual rear view of the vehicle & system will warn with message 'Tail Gate Open, Please close.'
- When the camera is operated under fluorescent lights, sodium light or mercury light etc., illuminated areas on the lens may appear to flicker in the display.
- Do not attach any advertisement or styling or any kind of stickers on top of camera. If this happens, camera cannot provide the visual image and it may damage the camera.
- Do not add any accessory, which will cause blockage to the camera's field of view.

Rear View Camera System Precautions

Area Displayed on Screen

The rear view camera system displays an image of the view from the bumper of the rear area of the vehicle.

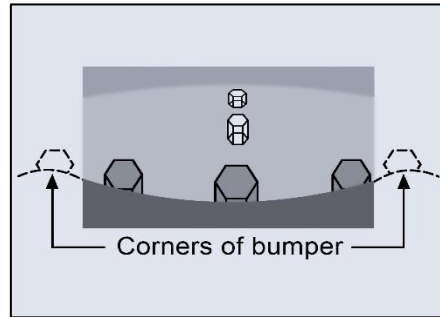
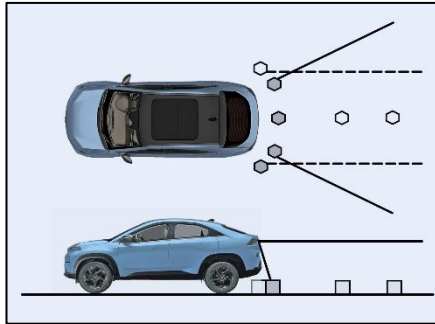

- The area displayed on the screen may vary according to vehicle orientation conditions.
- Objects, which are close to either corner of the bumper or under the bumper, cannot be seen on the screen.
- The camera uses a special lens. The distance of the image that appears on the screen differs from the actual distance. The camera may not display items that are located higher than the camera's field of view.

When sharp up gradient behind the vehicle

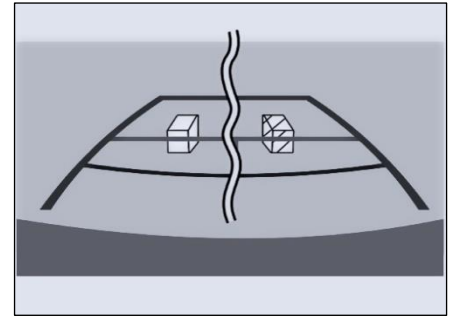
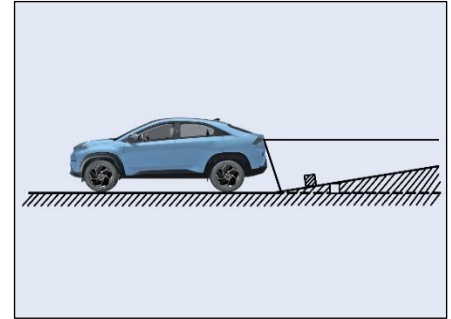

STARTING AND DRIVING

The distance guidelines will appear to be closer to the vehicle than the actual distance.

Because of this, objects will appear to be farther away than they actually are.

In the same way, there will be a margin of error between the guidelines and the actual distance/course on the road.

When sharp down gradient behind the vehicle

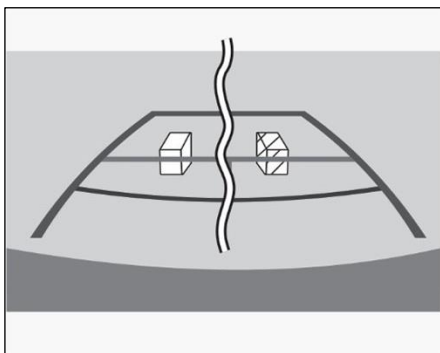
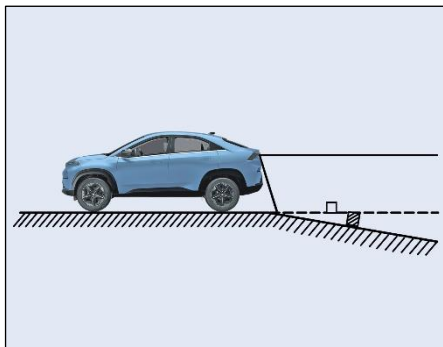

*i*NOTE

- *The distance guidelines will appear to be further from the vehicle than the actual distance.*
- *Because of this, objects will appear to be closer than they actually are. In the same way, there will be a margin of error between the guidelines and the actual distance/course on the road.*

When any part of the vehicle sags

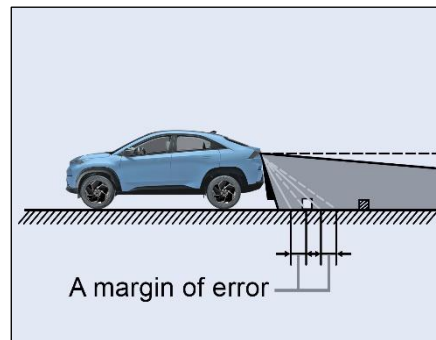

When any part of the vehicle sags due to the number of passengers or the distribution of the load, there is a margin of error between the fixed guide lines on the screen and the actual distance/course on the road.

When approaching three-dimensional objects

The distance guidelines are displayed according to flat surfaced objects (such as

the road). It is not possible to determine the position of three-dimensional objects (such as vehicles) using the distance guidelines. When approaching a three-dimensional object.

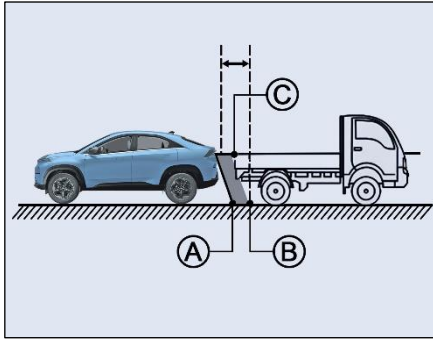

Visually check the surroundings and the area behind the vehicle. On the screen, it appears that a truck is parked at point B. However, in reality if you back up to point A, you will hit the truck. On the screen, it appears that A is closest and C is furthest away. However, in reality, the distance to A and C is the same, and B is further away from A and C.

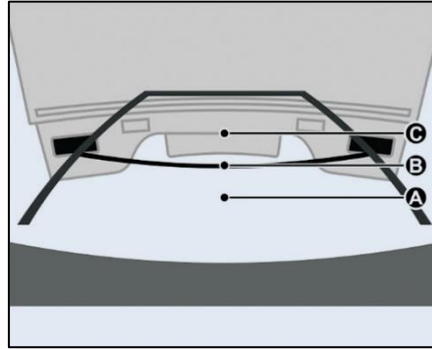

Vehicle width guidelines

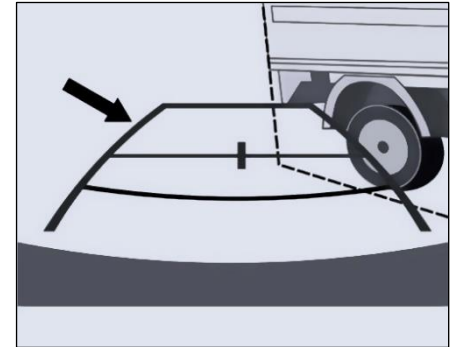
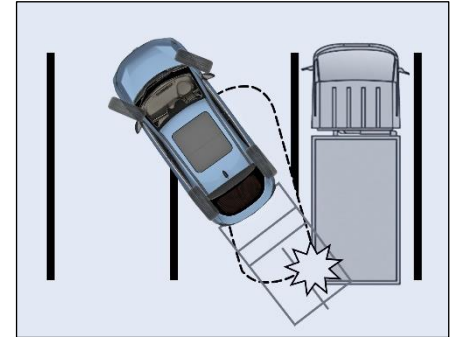

STARTING AND DRIVING

Visually check the surroundings and the area behind the vehicle. In the case shown below, the truck appears to be outside of the vehicle width guidelines and the vehicle does not look as if it hits the truck. However, the rear body of the truck may actually cross over the vehicle width guidelines. In reality if you back up as guided by the vehicle width guidelines, the vehicle may hit the truck.

Park Assist System (Front and Rear)

Park Assist System is an electronic parking aid that assist you to park vehicle safely when in reverse mode. It also provides front part assist (if equipped) if your vehicle speed is below 10Kmph and Front part assist option is enabled through infotainment screen.

It provides audio, visual information through vehicle infotainment system. Select this feature in infotainment display to see any obstacle behind/front of the vehicle.



The system also displays the Park assist screen when mono-shifter at reverse.

WARNING

0 to 25 cm obstacle detection performance is not guaranteed due to ultrasonic sensor technology limitation.

Variant where infotainment display is not present and audio warning is given through a buzzer, on activating the Park Assist system, a tone will be played within first two seconds to indicate the proper functioning of the system. After these two seconds, normal functioning of the system will continue. If no tone is heard for first two seconds, it shall mean that Park Assist System is faulty. The owner should, in that case, go to the nearest dealer for rectification.

Front Park Assist System (FPAS) (if equipped)



Activation Conditions

1. Front park assist option can be enabled through Infotainment screen.

Go to settings

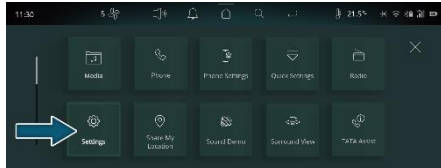

Select Driver Assistance



Enable front park assist option

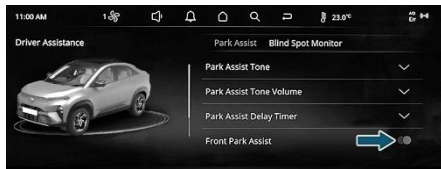

2. If reverse gear is engaged and Front-park assist option is enabled through infotainment screen.

3. If user has turned ON Low speed activation from user settings menu and vehicle speed is below 10 kmph (Forward Direction) and some object is detected in the front of the vehicle then audio warning for 10 sec will sound, while the visual warning will continue to be shown till the object is present.

Deactivation Condition

1. If vehicle is speed is above 10Kmph in drive mode.
2. If started through infotainment screen button, the system can be stopped using a Front Park Assist option on infotainment screen.

Approx. Distance Range From Bumper (in cm)	Visual Warning	Audible Information
25 – 30	Red Zone	Continuous Beep
31 – 60	Yellow Zone	Fast Beep
61 – 100	Green Zone	Slow Beep

Reverse Park Assist System (RPAS) (if equipped)



Activation Condition

This system will start, if reverse gear is engaged, or park assist button (if equipped) is pressed or manual activation is done through Infotainment screen.

Deactivation Condition

System will stop if park assist button (if equipped) is pressed.

If started through infotainment, the system can be stopped using a cross button on infotainment screen.

STARTING AND DRIVING

Approx. Dis- tance Range From Bumper (in cm)	Audible In- forma- tion
25 – 40	Continuous Beep
41 – 80	Fast Beep
81 – 120	Slow Beep

NOTE

Audio warning may come from Infotainment system speaker or through Buzzer, depending on vehicle model and configuration.

Park Assist System Limitations

Park Assist system is not a collision avoiding system. It is solely the driver's responsibility to park the vehicle safely. Park Assist feature works on ultra sound echo technology, due to which performance is not guaranteed in following scenarios:

- If the object has a sharp edge surface, where surface may divert echoes from sensor reception.

- If object is mesh fence made up of thin wires, where echoes can't be given by the surface.
- Fast moving objects passes in the sensor's field of detection, where echoes are not processed by the system.
- If object is made/covered by foam or sponge or snow where ultrasonic sound signals are absorbed.
- Objects close to the rear bumper can go undetected by the Reverse Park Assist's field of detection. Driver should use extreme caution while parking the vehicle.
- If height of the bumper is changed due to alteration to the suspension or other causes.
- If the sensor areas are extremely hot from direct sunlight or cold due to freezing weather.
- If Sensors are covered by a hand, sticker, accessory, etc.
- If ultrasonic noise is present around Vehicle due to other vehicle sensors, horn, air braking system (large vehicles), Exhaust Fans, Wireless transmitters or mobile phones.
- If the vehicle speed exceeds 10kmph, the system will not warn you even though objects are detected, error message 'Vehicle Speed is high, drive slowly!' will appear.
- Driving on uneven road surfaces e.g. Gravel, unpaved roads, Artificial Speed Breakers, or gradient.
- Poles of square/rectangular cross section might not be detected due to the ultrasonic technology limitation. If trailer is connected.

WARNING

Due to any reason, if the sensor gets misaligned or loses its intended fitment position, contact your dealer for refitment.

NOTE

Turning the ignition 'OFF' while the park assist feature is active would disable it.

NOTE

Parking sensor performance may affect in case use of unauthorized registration plate. Use RTO authorized size registration plate only. High security registration plate dimension in mm – 500 x 120 (Approx).

Park Assist System Preventive Maintenance/cleaning

1. Regularly clean the sensors and keep them free from dust, ice, mud, water, chewing gum etc. for proper working of the system. Use a smooth cloth for cleaning.
2. Do not use water at high pressure for cleaning the sensor.
3. Do not cover the sensors. This will interrupt park assist performance.

4. Do not remove mud, snow on the sensors using stick or hard material. Use normal water and soft cloth.

Park Assist Malfunction Indications

In case of park assist system malfunctions, fault screen may appear on the infotainment system.

Reason for this fault may be

1. Body Control Module Failure
2. Sensor Malfunction
3. Partner components such as Infotainment music system, Instrument Cluster failure

STARTING AND DRIVING

AUTOMATIC VEHICLE HOLD (if equipped)



AVH holds the brakes once vehicle speed reaches zero at traffic lights or a junction, thus avoids unintended vehicle rolling. Once activated through AVH switch Automatic Vehicle Hold maintains brake force even after you release the Brake Pedal. You can then release the brake pedal and remain stopped, even on a hill. To disengage AVH, press the accelerator pedal

How to Apply

1. Depress the Brake pedal.
2. Ensure seatbelt is fasten and driver's door is closed.
3. Press AVH switch.
4. Auto Hold indication turns on in the Cluster which indicates AVH is turned ON and in Standby mode.
5. When the vehicle reaches the standstill condition though brake pedal is released AVH holds the vehicle and AVH indication changes the color from white to green.

AVH will be released when accelerator pedal is depressed in R (Reverse), D (Drive).

iNOTE

- *When the vehicle is turned off keeping the Auto Vehicle Hold in the ON condition, Auto Vehicle Hold will get released and EPB will get automatically applied.*
- *For safety, for smooth take off depress the accelerator pedal slowly when the AVH is active.*

Vehicle Hold Warning Indicator

AVH indication and warning lamps turns ON (white which will appear on the cluster is provided below).



AVH indication ON



AVH active indication (Green color)



AVH failure indication (Amber color)

How to Disengage AVH

In Ignition ON Condition depress the Auto hold switch the Auto Hold indication in white color will disappear from the cluster indicating AVH is turned off.

AVH once turned ON will not be turned off automatically until it is deselected by switch input from user.

NOTE

Auto hold function will not become active if

- *Driver Seat belt is not buckled.*
- *Driver Door is not closed properly. EPB is in applied condition.*

For end user safety Auto hold will shift automatically to EPB in below conditions:

1. Vehicle is in standstill for more than 3 minutes.
2. Mono-shifter from any of Drive (D), Reverse(R) to Park (P) Position.
3. If you turn OFF the vehicle/Ignition in standstill condition.
4. Vehicle is standing on steep slope.

In above conditions AVH indication will change from Green to white and EPB indication will turn on in the cluster.

WARNING

If any abnormality is present in the system, AVH malfunction lamp in Amber color will glow. Kindly do the ignition switch OFF for 30 seconds and check if the same behavior is there. If the Malfunction lamp is still there, get your parking brake system checked with the TATA MOTORS EV Authorised Service Centre.

STARTING AND DRIVING

ADVANCED DRIVER ASSISTANCE SYSTEMS (ADAS) (if equipped)

The Advanced Driver Assistance System (ADAS) provides the alerts and controls to improve the overall safety of vehicle and increases the driver comfort.

WARNING

- ADAS is only an aid system, it is NOT a substitute for the driver's attention. The driver must always remain in control of the vehicle, observe the surroundings and drive safely.
- ADAS system is assist system for driver for comfort driving. The driver should observe surroundings environment obstacles in vehicle path and judge distance of vehicle from obstacle and apply enough braking. Driver should also observe traffic signs on road, lane marking always and act accordingly.
- The correct operation of the ADAS sensors will be compromised if they

are misaligned due to accident damage at the windshield/bumper area of the vehicle.

Limitations of Advanced Driver Assistance System

There might be degraded/no/unexpected functionality of ADAS in following cases:

- There is adverse environmental conditions such as heavy snow, heavy rain, etc.
- The ADAS sensors are covered/blocked with snow, dirt, mud, etc.
- There is splash on ADAS sensors due to water logging on the road.
- The temperature around the ADAS sensors is too high or too low.
- A trailer, carrier or other attachment is installed in your vehicle.
- The bumper around the radars is covered with objects such as a stickers, guards, paint, bike rack etc.
- The area around the radars is impacted, damaged or the radars are out of position.
- Windshield area around the ADAS camera is damaged or camera is out of position.
- Your vehicle height is low due to heavy loads, abnormal tyre pressure (tyre pressure is low, uneven) or a tyre is damaged, etc.
- The road contains multiple metallic components (for example, metallic bridges, metal construction poles etc).
- The vehicle drives on a curved road.
- The vehicle severely vibrates while driving on bumpy/uneven paths.
- When the ADAS sensors are blocked by other vehicles, walls or parking-lot pillars.
- The vehicle is driven through a toll-gate.
- Driving on a road where trees or grass are overgrown.
- Driving in areas where the sensor does not detect another vehicle or structure (like bullock cart, horse cart etc) for an extended period of time.

- When an object or vehicle makes sharp lane changes or driving direction changes.
- ADAS features may not operate properly when driving where the heights of the adjacent lanes are different. The function may not detect the vehicle on a road with different lane heights (underpass joining section, grade separated intersections, etc.).
- ADAS features may not operate properly on sloped road conditions.
- ADAS features may not operate properly if interfered by strong electromagnetic waves.
- ADAS features may not operate properly when there are structures beside the driving road. In certain instances, the system may degrade while recognizing the structures (guardrails, street light, road sign, tunnel wall, overhead structures etc.) beside the road.
- Driving on narrow roads.
- A motorcycle or bicycle is near or any vehicle approaches too close.

- In certain complex environmental situations or sensors misaligned, ADAS system may provide false warning or braking or may not provide warning or braking for objects.

NOTE

- *Vehicles bumper and windshield should be kept free of snow, ice, mud and must not be covered by any material so as to ensure proper working of ADAS features.*
- *Keep the bumpers and windshield clean.*
- *Radar based functionalities and warnings are given only for moving objects.*

*If any damage to bumper/windshield of the vehicle, it is recommended to get the vehicle inspected by TATA MOTORS EV Authorised Dealer.

Following are the features of Front and Rear ADAS

1. Forward Collision Warning (FCW) and Automatic Emergency Braking (AEB)
2. Lane Keep Assist (LKA) and Lane Depart Warning (LDW)
3. Adaptive Steering Assist (ASA) / Lane Centering System (LCS)
4. Adaptive Cruise Control (ACC) (if equipped)
5. High Beam Assist (HBA)
6. Traffic Sign Recognition (TSR)
7. Driver Dose off Alert System (DDOA)
8. Blind Spot Detection (BSD) and Lane Change Alert (LCA)
9. Rear Cross Traffic Alert (RCTA)
10. Door Open Alert (DOA)
11. Rear Collision Warning (RCW)

STARTING AND DRIVING

Front Advanced Driver Assistance System (Front ADAS)

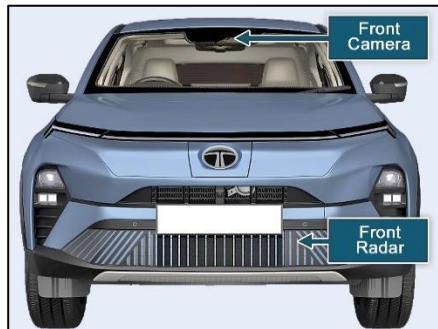

Front ADAS features uses front radar and front windshield camera, as shown in above image.

1. Forward Collision Warning and Automatic Emergency Braking (FCW & AEB)

Forward Collision Warning System warns the driver by providing audio and visual warning when there is a possibility of collision with the preceding 4 wheelers, cyclists or pedestrians detected ahead. Automatic Emergency

Braking system avoids accident or mitigates collision impact by applying brake whenever driver applied brake is not sufficient or not applied.

Prerequisite for Activation

The following condition shall be satisfied for FCW and AEB to activate.

1. Front camera and front radar are fault/blockage free.
2. Front windshield should be clean.
3. Front bumper should be clean.
4. Vehicle speed should be 7-180 kmph approximately.
5. Vehicle shall be in Drive or Neutral Mode.
6. Steering wheel position should be stable and not to be turned suddenly.
7. No other system failures or degradation of functions related to AEB systems like Braking system, Steering system etc.

User Settings

FCW and AEB shall be default ON during start of Vehicle.

When vehicle is at standstill user can select FCW-AEB features settings from infotainment as below:

Go to Home page >> All App >> Settings >> Driver Assistance >> Drive assist.

1. User can turn OFF FCW-AEB feature.
2. User can turn ON only FCW or both FCW and AEB.
3. Select FCW sensitivity (low, medium and high) to adjust the distance at which collision warnings are provided:
 - Low - FCW is provided at a lower than normal distance to collision risk
 - Medium - FCW is provided at normal distance to collision risk
 - High - FCW is provided at a higher than normal distance to collision risk

Feature Operation

Warning Behavior (When FCW and AEB Both OFF)



When both FCW and AEB are disabled, the system does not respond to collision risks then

this tell-tale will appear on the instrument cluster panel.

Warning Behavior (When Only FCW is ON)



When Only FCW is ON, the system gives only one level of warning. The driver is alerted to the risk of an imminent collision by visual and audible warning which may be accompanied by a short brake pulse.

Warning Behavior (When FCW and AEB Both ON)

When both FCW and AEB are ON, the system gives two level of warning along

with brake intervention as described below.



1st Warning - The driver is alerted to the risk of an imminent collision by visual and audible warning which may be accompanied by a short brake pulse.



2nd Warning - If the driver does not take action or the driver braking force is not enough to mitigate collision, system issues the second level of visual and audible warning and applies emergency braking.

After the vehicle has come to a complete halt post emergency braking, the system holds the vehicle stationary for around 2 seconds. After these 2 seconds it is driver's responsibility to control the vehicle and to prevent it from moving forward or creeping.

STARTING AND DRIVING

Feature Failure



When system fails due to some obstruction/blockage of front camera or radar then FCW-AEB feature works in degraded mode. In this case tell-tale may appear on instrument cluster and visual warning pop up will appear along with audio warning.

To resolve this failure the user should clean the front camera or radar for any obstruction/blockage. If the issue still persists then turn Ignition OFF to ON. If the issue is still there then visit TATA MOTORS EV Authorised Service Centre.

FCW-AEB System Warning



FCW-AEB Limited Performance
Due to Camera Blockage

OK

System Limitation Scenarios

FCW-AEB system may be unavailable or degrade performance will be there in following situations.

- Close cut-in situations, where another vehicle cuts-in from an adjacent lane at close range.

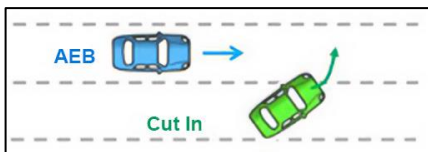

Intersection crossing scenarios, where other vehicles may approach at an angle to driving path.

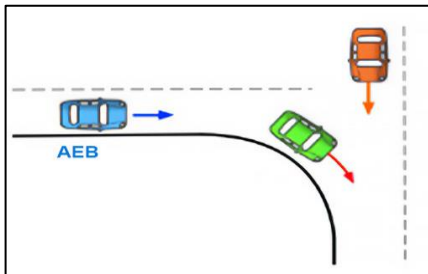

- Hill Situation

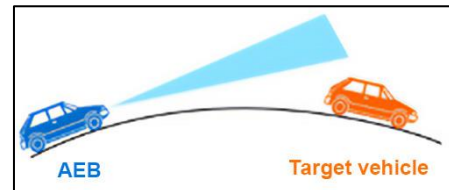

Target vehicle is not detected due to road inclination uphill and downhill situation.

- Special Vehicles / Vehicle with specific load

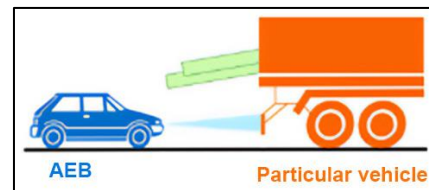

When a specific type of load is loaded or a special vehicle, it can collide due to the sensor detection limitation.

STARTING AND DRIVING

- Sensor Blockage

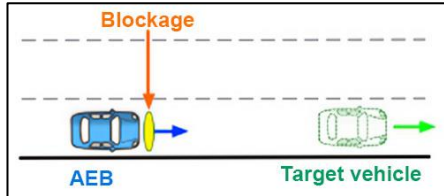

In case of front radar or camera contamination / blockage, collision with the front vehicles or other objects may occur.

- Large Curve Road

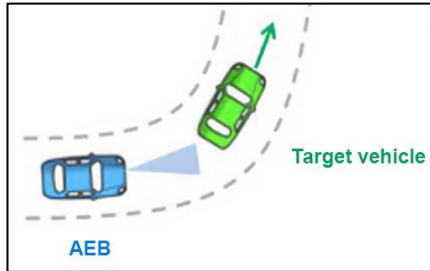

When driving on a large curve road, due to the sensor limitation, collision with the front vehicles or other objects may occur.

- Driver field of vision

In extreme weather condition (snow, rain, fog, etc.), the sensor limitation may cause a collision between the vehicle and other objects ahead.

- Two-Wheeler movement

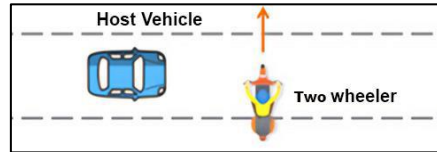

If there is collision danger with two wheeler that moves laterally, collision is possible due to limitations of sensors.

- Low Camera visibility

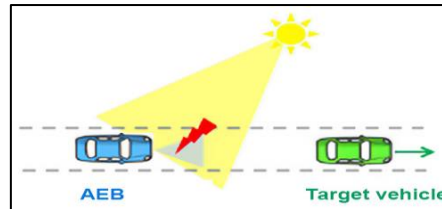

Possible collision with forward vehicles or other objects in situations where the camera's visibility is low due to backlight, reflected light, direct sunlight glare, darkness etc.

- Front vehicle asymmetrical Tail light at night

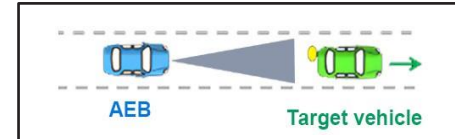

Possible collision due to camera limitations if there is no tail light of the front vehicle at night or if the mounting position is asymmetrical.

- Detection problem due to complicated structure on the road.

If a construction section, railroad track, or other metallic object is on the road (eg, tollgate, subway construction site, tunnel, lane-proximity guardrail, etc.) then there can be possible collision. Pedestrians suddenly jumping in front of the vehicle.

STARTING AND DRIVING

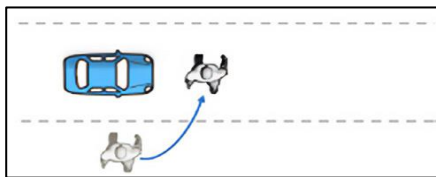

Possible collision if pedestrian suddenly jumps in area where sensor cannot detect.

- If a part of the body of the pedestrian is a covered or standing pedestrian

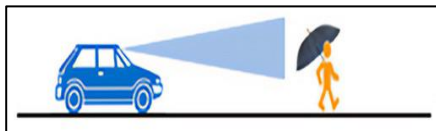

In the case of pedestrians whose body part is obscured by umbrellas, bags, special clothes, etc., they cannot be detected and collision may happen. A pedestrian sitting / lying down may collide due to no detection.

- Low illumination

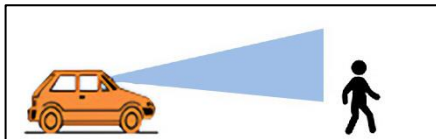

If the illumination is low, possible collision may occur with objects due to no detection by camera.

- Fast moving pedestrians

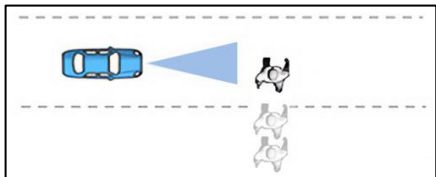

Possible collision with fast moving pedestrians due to sensor limitations

- Small pedestrians

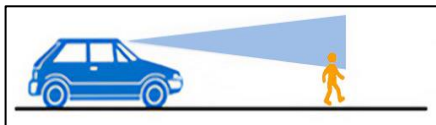

Possible collision with small pedestrians due to no detection in camera.

Performance degradation of radar and camera in extreme weather condition (rain, fog, snow, etc.) and during metallic poles, fences etc. In these scenarios there can be false warning and braking observed by the system, hence, the driver is advised to not rely on the ADAS system in such scenarios.

When approaching forward vehicles, pedestrians or bicyclists with low overlap.

- The FCW-AEB system is a collision mitigation system. It does not always guarantee collision avoidance. Driver has to keep attention on road always for any possible collision.
- When driving above 85 kmph, where only partial braking is applied by AEB.
- When approaching pedestrians or bicyclists at above 65 kmph, where the system does not intervene.
- AEB for Vehicles - Junction Turning

To ensure that the FCW-AEB system detects an approaching vehicle in Junction

Turning case, the vehicle must be driven at a low speed and oncoming vehicle should be clearly visible. The subject vehicle should be in left lane making a right turn with turn indicator ON.

In junction turning scenarios, FCW-AEB system applies brakes and there may be no warning. Depending on the situation, the system may be able to mitigate the collision but not avoid it completely. The driver is solely responsible for always driving while maintaining a safe speed and safe distance.

- AEB will not work under following conditions:
 - I. When driver applies Steering in order to avoid a collision
 - II. When the driver presses the accelerator pedal beyond a certain limit
 - III. When target vehicle or object ahead is not detected anymore.
- For some special obstacles like barricades, cows and other animals, there is a possibility that FCW warning and braking may not be operational.

Disclaimer

- FCW-AEB system may not work in all-weather /traffic conditions.
- FCW-AEB system is able to detect 4 wheelers, pedestrian, and cyclists but not in all conditions.
- The driver is solely responsible for maintaining safe speed and distance in all conditions.
- The driver has to follow warnings and instructions before use of FCW-AEB system to avoid serious injury or death.
- It should be noted that AEB system cannot guarantee to work 100% effectively in all situations.
- FCW-AEB system should never be tested by driving towards a person or object or animal. This may result in serious injury or loss of life.
- FCW-AEB system may not provide warning and braking for objects in crossing and sometimes in stationary position

- FCW-AEB system works by predicting the path and direction of travel of obstacles. In certain complex environment situations or sensors misaligned. The system may provide false warning or braking or may not provide warning or braking for front object.
- During AEB collision the passengers can experience great discomfort and high jerk while the system applies maximum possible brake to avoid/mitigate the collision. This can cause minor to medium level injuries to the passenger. It is advisable that to avoid major injuries the passengers should always wear seatbelt.

In situations where there is water on the road, there may be false detections and false warning and braking may be given.

STARTING AND DRIVING

2. Lane Keep Assist (LKA) equipped with Lane Departure Warning (LDW)

It is a safety feature which helps the driver to keep the vehicle in the lane by providing warning and steering inputs to the user when vehicle departs the lane without driver's intention.

Whenever vehicle moves towards lane edge, driver is alerted with LDW and LKA brings the vehicle back into the lane.

Prerequisite for activation

The following conditions shall be satisfied to activate LKA-LDW

- Front Camera is fault/ blockage free.
- Front windshield should be clean.
- Vehicle speed is more than 60Kmph.
- Vehicle shall be in Drive mode
- Steering wheel position should be stable and not to be turned suddenly.
- Lane markings are properly detected and a lane is properly recognized.
- Turn Indicator of the side of departure is OFF.

- In case turn signal is given, LKA will resume after few sec when Turn signal is turned OFF.
- No other system failures or malfunction related to Steering system.

WARNING

This is a driving assist system for comfort driving, however driver should always be attentive while driving.

User Settings

ASA & LKA-LDW shall be default ON at start of vehicle

User can select this feature through infotainment system user interface:

Go to Home page >> All App >> Settings >> Driver Assistance >> Drive assist

1. User can enable or disable the LDW-LKA feature.
2. User can select only LDW or LDW and LKA both.
3. When both LDW & LKA are ON, below points user shall refer:
 - If LKA-LDW is activated through infotainment setting screen and user

presses steering wheel switch, LKA-LDW gets activated.

- If LKA-LDW is activated through infotainment setting screen and user presses steering wheel switch, LKA only will get deactivated and LDW will be activated.
- If LKA-LDW is activated from steering wheel switch and user deactivates it from infotainment setting screen, it will get deactivated.
- If LKA is deactivated from steering wheel switch and user activates it from infotainment setting screen, LKA+LDW will get activated.

Warning Indicators (When LDW and LKA both ON)



When both lanes not recognized / Vehicle speed <60kmph. Feature will be in standby mode and tell-tale will appear in white color on Instrument cluster.



When one of operating condition is not satisfied (either one lane detected, or both lanes detected). Feature will be in standby state and tell-tale will appear in instrument cluster. (Lane will be in white color and vehicle in green color).



When both lanes recognized & vehicle speed > 60 Kmph then tell-tale will blink for few sec on instrument cluster. If either right or left lane detected then only that lane will be in green, vehicle and other lane will be in white color.



When vehicle departed either left or right lane then tell-tale will blink for few

sec with 3 times audio alert and vehicle and crossed lane will be in red color.



Visual warning in case of system failure "Lane Departure Warning - Lane Keep Assist System Failure Please contact service centre" will appear in amber color.

Audio warning for few sec in case of calibration issue "Lane Departure Warning - Lane Keep Assist System Not calibrated. Please contact service centre".



When LKA feature is active steering correction tell-tale will appear in Instrument cluster in green color.



LKA feature gives audio and visual warnings in case of hands OFF situation and next intervention occurring within 180 sec, however driver should always be attentive while driving.

NOTE

If steering wheel is hold with very light grip, system will prompt user to keep hands on steering wheel.

WARNING

Warning will be deactivated once driver keep the hands on steering wheel.

NOTE

LKA and LDW will not work for the side where vehicle is drifting when same side of indicator signal is ON.

Warning Indicator (When only LDW ON)



When LKA-LDW feature fails or system is not calibrated then tell-tale will appear on instrument cluster in amber color.

Visual warning in case of system failure "Lane Departure Warning System Failure Please contact service centre".

STARTING AND DRIVING

Audio warning for few sec in case of calibration issue with visual warning "Lane Departure Warning System Not calibrated. Please contact service centre".

System Limitation Scenarios

LKA-LDW system is subject to system limitations and may be unavailable or degraded performance or give false warnings in following situations.

In these situations, it is advisable to turn the LKA-LDW function OFF and driver should take full control of the vehicle:

- Road Edges are not detected if vehicle is departing lane
- Road under construction
- Reduced visibility due to bad weather on account of rain, fog, snow etc
- Roads with indistinct/faded lane markings
- Road sections with sharp curves
- Narrow roads
- High speed driving especially in sharp curves
- Road sections where there are turn lanes or when the original lane merges or separates
- Passing through tunnels when brightness changes suddenly.
- Horizontal or vertical slope
- Preceding vehicle obstructing lane visibility
- Improper headlight aiming/headlight covered with dirt
- Any other environmental conditions affecting camera vision
- Poor visibility due to sun glare or blockage in lens
- Non Standard Lane Marking (e.g. Rural road lane marking, cat eye lane marking, width of lane marking is not as per IRC standard etc)
- When driving on a road with reflective material on the road surface that may interfere with lane marking detection.
- All other painted signs on a road such as a road sign, an arrow, a zebra crossing, a figure, a letter, tyre mark, etc.
- When lane like pattern is formed on the road due to any spillage or grass, tiles/road, system may provide unexpected lane departure warning.
- All artificial structures near a lane such as a guardrail, an outer wall of a tunnel, a sidewalk, curb and a lane change prohibition bar, etc.
- Shadow of all artificial structure and other vehicles.
- Preceding vehicle and a cut-in/out vehicle.
- A boundary between asphalt road and concrete road.
- Erased, faded, or damaged lane.
- An edge occurred by color discontinuity of asphalt.
- When there are duplicate lane markings in close proximity.
- When there are hatch and hazard markings in between lane markings.

WARNING

LKA-LDW is intended to assist the driver and thus driver should pay attention to the road all the times, taking primary responsibility of driving.

This feature cannot function as intended in all kinds of driving, weather, traffic and road conditions.

3. Adaptive Steering Assist (ASA) / Lane Centering System (LCS) (If equipped)

Adaptive Steering Assist (ASA) maintains the vehicle's position at the centre of a lane.

The system works on the basis of detected lane markings and helps reduce the steering effort required of the driver, by providing continuous steering corrections.

When conditions are met, in the absence of adequate lane markings, the system can also follow the path of a preceding vehicle, increasing the availability of the system. The driver can override the system at any time by applying positive steering

inputs or accelerator pedal input.



The system requires the driver to hold the steering wheel at all times and pay attention to the road.

Adaptive Steering Assist works along with Adaptive Cruise Control (ACC). Thus, Adaptive Steering Assist requires ACC to be activated.

Prerequisite for activation

The following conditions shall be satisfied to activate ASA:

- ASA is enabled through driver assist settings.

- Adaptive Cruise Control is active and not overridden by driver accelerator pedal input.
- All prerequisites of ACC are met.
- Standard lane markings are detected clearly on any one side.
- Lane width is as per standard road building norms applicable to the country (typically 2.5-4.5 metres)
- The vehicle position is stable, entirely within lane boundaries and the lane is recognized by the system.
- Turn indicators are OFF.
- Steering wheel position should be stable and not to be turned suddenly.
- Vehicle speed should be within 30 to 165 kmph.
- No malfunctions of Adaptive Steering Assist & Electronic Stability Control systems

Once activated, the system can continue operation when lane markings are detected on only one side, or if lane markings are not detected on either side but a preceding vehicle is being followed.

STARTING AND DRIVING

User Settings

Adaptive Steering Assist shall be by default, ON with each new start cycle of the vehicle.

Adaptive Steering Assist can be selected from the driver assist settings from Infotainment screen.

Follow the following sequence:

Go to Home page » All Apps » Settings » Driver Assist

Following the Preceding Vehicle Path

The system can follow the path of a preceding vehicle (excluding 2-wheeled vehicles such as bicycles, motorcycles, scooters etc.) and continue offering assistance even when lane marking detection is not clear, when the following conditions are met:

- Vehicle speed is lower than 75 km/hr (once activated, this mode of control shall be released when the vehicle speed exceeds 80 km/hr).
- Distance between driven vehicle and preceding vehicle is within 50 meters

(once activated, this mode of control shall be released when the distance exceeds 70 meters).

- The preceding vehicle's path has not deviated too much with respect to driven vehicle, or with respect to the path predicted for the preceding vehicle by the system.

System Limitation Scenarios

ASA system is subject to system limitations and may be unavailable or degraded performance or give false warnings in following situations.

- Inclement weather (rain, snow, fog, dust, haze, mist etc.)
- Camera blockage (direct sunlight or headlamp glare on camera, mud/dirt/moisture/ stickers/ debris on windshield surface in front of camera etc.)
- Low ambient light (headlamps of driven vehicle/ tail lamps of preceding vehicle not working or providing insufficient illumination, no/ inadequate street lighting, loss of lane marking retro reflectivity etc.)

- Strong shadows falling across road or vehicles.
- Faded lane markings or obscuration of markings due to barricading, dirt, debris, water, oil, traffic, poor road surface, construction activity etc.
- Non Standard Lane Marking Like Rural road lane marking, cat eye lane marking, width of lane marking is not as per IRC standard etc.
- Low contrast of vehicles with horizon, lane markings with road surface
- Passing through a tunnel (sudden brightness change).
- Road curves that are very sharp or vehicle speed that is too high for a curve (typically, standard highway curves can be managed by the system at applicable highway speed limits)
- Merging or diverging lane markings, duplicate lane markings, intersections where lane markings disappear.

- Road seam lines that create a contrast similar to lane markings, causing misdetection of actual lane markings and/ or improper control.
- High road camber
- Tyre pressure not as per recommended specification
- High vertical slopes
- Rough roads, undulating road surfaces, high occurrence of rumble strips, speed breakers, potholes etc.
- Frequent presence of multiple vehicles in the same lane or moving along lane edges (such as 2-wheeled vehicles and cars occupying the same lane, weaving in and out of the lane along the lane edge or a wide load body of a truck or bus intruding into the lane).

NOTE

The ASA system cannot control vehicle position basis vehicles or objects on the side and the driver must monitor the environment and ensure safe steering at all times.

WARNING

It is recommended that the system is primarily used on highways with good lane markings, smooth road surface, gradual curves/ gradients/ camber designed for highway speeds and traffic moving at highway speeds with good lane discipline.

Warning Indicators



When Adaptive Steering Assist is ON but in the standby state, due to any of the pre-conditions not being met, this tell-tale is displayed in the Instrument Cluster, in grey colour.



When the Adaptive Steering Assist feature is ON and active (the feature is actively controlling vehicle position for maintaining lane centre), the following tell-tale is displayed in the Instrument Cluster, in green colour.



When a system failure of Adaptive Steering Assist is detected, this tell-tale is displayed in the Instrument Cluster, along with visual warning “Adaptive Steering Assist malfunction. Please contact service centre”.

Warning Indicator in case of Hands OFF situation

ASA feature gives audio and visual warnings in case of hands OFF situation.

STARTING AND DRIVING

If the driver takes their hands off the wheel, the system allows operation for a limited time and then deactivates both Adaptive Cruise Control and Adaptive Steering Assist giving prior warnings as follow:

- First instant warning - After taking hands off steering wheel green coloured graphic prompting the driver to hold the steering wheel, accompanied by a single audio alert.



- Second instant warning - After taking hands off steering wheel – amber coloured graphic prompting the driver to hold the steering wheel, accompanied by a continuous audio alert.



- Third instant warning - After taking hands off steering wheel – both Adaptive Cruise Control and Adaptive Steering Assist deactivated. A deactivation message will be displayed as follows – 'Adaptive Steering Assist system deactivated' accompanied by a single audio alert.
- At any point during the above sequence, if the driver restores hands on the steering wheel, the sequence is aborted and warnings are withdrawn.

NOTE

If steering wheel is hold with very light grip, system will prompt user to keep hands on steering wheel.

4. Adaptive Cruise Control (ACC) (if equipped)

Adaptive Cruise Control (ACC) is a comfort feature that allows a vehicle's cruise control system to adapt the host vehicle's speed automatically even in traffic conditions. Feature detects vehicles, which are in the host vehicle's path. If slower moving vehicle is detected the ACC system will slow down the host vehicle speed and maintain appropriate distance from the target vehicle. If the system detects that the forward vehicle is no longer present in the host vehicle's path, the system will accelerate the vehicle back to its set cruise control speed.

The feature identifies the nature of traffic and distance from other vehicles and help to adjust the speed and distance of the host vehicle according to vehicle moving in front.

Disclaimer

- ACC is drive assist feature and it will not avoid collision.
- Please read and understand Owner's Manual before using ACC feature in

real conditions. Driver should be always careful and attentive while using ACC feature.

- Driver is always responsible when driving vehicle and in all environment conditions even if ACC is performing its control.
- Driver should follow all safety rules and regulations, traffic rules. Its driver responsibility to be alert and driver should have always control on vehicle even in ACC on mode.
- Driver should have safe and proper distance from preceding vehicle and apply brake on time as per real situation if system does not decelerate vehicle or does not maintain speed or distance from preceding vehicle.
- Driver should not validate ACC feature in real road conditions, incorrect way to use ACC may lead to severe accident and damage.
- Driver should always follow ACC alerts or warning given by system.

- ACC may decelerate slowly or may not stop the vehicle in time so driver should always be attentive and intervene through applying brake if required.
- Always drive in ACC active mode within speed limits.
- ACC should be used in less or moderate traffic road conditions. Use of ACC where pedestrians crossing path is normal may lead to accident.
- ACC may not detect target and decelerate speed when any four-wheeler or two-wheeler cut-in immediately.
- ACC should always use in well-constructed and maintained road conditions.
- ACC should always use on road where clear visible lane marking and signboards are available.

ACC Switches



The steering wheel switches are used for ACC operations.

ACC Cruise ON/OFF: This button is used to ON/OFF the ACC function.



ACC Cruise RESUME/CANCEL: This button is used to resume to the initial set speed OR cancel the ACC function temporarily in same IGN cycle.



STARTING AND DRIVING

ACC SET+: This button is used to increase the Set speed. If user presses button for short duration, then set speed will increase by 1kph and for long press set speed will increase by 10kph.



ACC SET-: This button is used to decrease the Set speed. If user presses button for short duration, then set speed will decrease by 1kph and for long press set speed will decrease by 10kph.



ACC Time Gap: This button is used to set the desired distance between the host vehicle and the target vehicle.

Pre-requisites for Activation

- Front camera and front radar are fault/blockage free.
- Front windshield and front bumper should be clean.
- Vehicle shall be in Drive Mode.
- Driver Seat belt should be buckle.

- Driver Door should be close.
- Autonomous braking feature should be enabled from User settings.
- Park Brake should not be engaged. Brake Pedal should not be pressed

Accelerator pedal should not be pressed
Vehicle speed should be within 7-180 kmph approximately.

No other system failures or degradation of functions related to AEB systems like Braking system, Steering system etc.

FCW + AEB feature should be active from ADAS setting menu.

User Settings (Steering Wheel)

- When User presses ACC ON button from Steering wheel, this turns ACC in Standby Mode.
- Once vehicle speed is above 7 kmph and user presses the Resume button on steering wheel, this turns ACC in engaged mode and vehicle speed will set to 30 Kmph.

- When User presses ACC RESUME OR SET+/SET- short or long button from steering wheel, this turns ACC standby mode to ACC active mode unless any feature inhibit conditions are true.
- When user presses SET+/- button ACC set speed will increase/decrease.
- When user presses Cancel button from steering wheel, this turns ACC from Engaged to Standby.
- During ACC active follow mode if vehicle stops for more than 5 sec then user has to press resume button to engage ACC again.
- When ACC is in standby mode and user presses ACC Time Gap switch for long duration then ACC will turn to CC standby mode. If user wants to transit from CC to ACC mode again then user need to press same button (ACC Time Gap Switch).

- User can change/set the time gap in active and standby mode by pressing ACC time gap switch.
- When User presses ACC OFF button from Steering wheel, this turns ACC OFF.
- When User Engages ACC at a speed lower than 30kmph and more than 7 kmph, then ACC speed will be set as 30kmph and vehicle speed will increase to 30kmph if there is no obstacle present in the path.
- When User Engages ACC at a speed higher than 30kpmh, then that speed will be set as ACC speed and vehicle will cruise at that speed if no obstacle is present in the path.
- If ACC is ON and User Activates the Hill Descent Control (HDC) function by pressing the HDC button, then ACC will be OFF/Standby. If HDC is already activated and user tries to activate the ACC, then ACC won't be active. HDC function has always higher priority than ACC.
- Overtake Assist Control (OAC): During the Follow Control mode, if the driver wants to overtake the target vehicle, OAC function will help to overtake the target vehicle by enhancing the acceleration smoothly. For OAC activation, Turn indicator must be ON and minimum host vehicle speed should be 20kmph.

ACC Modes

- **Active Cruise Mode** – If there is no vehicle in the path of subject vehicle, then it will cruise at a speed equal to ACC set speed.
- **Active Follow Mode** – If there is a vehicle in the path of the subject vehicle, then it will maintain a distance from the target vehicle equivalent to the distance set by the user.
- **Stop - Hold Mode** – If the preceding vehicle is stopped then host vehicle will also stop. If the preceding vehicle moves then host vehicle will also move without user intervention. Now after 5 sec of stop mode to restart

ACC user intervention is required irrespective of preceding vehicle. User can exist from stop hold mode by double pressing ACC resume/Cancel button.



Adaptive Cruise Control to Normal Cruise Control transition

To switch from ACC to CC (NCC) First press the headway switch for more than 2sec when ACC is OFF, then press the ACC switch ,and in the cluster "CC Standby" (white telltale) will be seen then activation occurs by pressing the resume button once the vehicle speed exceeds 30 km/h.

- **ACC Tell-tale Behaviours**
- **Standby Mode** – During this mode ACC will be ON in standby mode as user presses ACC ON/OFF switch. ACC will not perform any control in standby mode. This tell-tale will be shown to user in white color.
- **Active Mode** – During this mode ACC will be in engaged mode and control

STARTING AND DRIVING

for ACC function is performed as per valid target detection. In ACC active mode above telltale will be shown to user in green color

ACC Display Behaviour

- When ACC is in active cruise mode, Only subject vehicle to be shown to user
- When ACC is in active follow mode then target vehicle will be shown in blue color
- When ACC is in standby mode then only subject vehicle to be shown to user.

ACC Warning Behaviour

1. Warning behavior when ACC is in Override.



- When ACC is Active, driver takes the control of the Vehicle by pressing accelerator. Below popup will appear on the instrument cluster panel.

2. Warning behavior when ACC is Available to Resume.

- When Vehicle stopped following a target vehicle and ACC is Active, Driver can resume the vehicle by pressing Resume switch or Acceleration pedal to restart the ACC if the target vehicle moves. Below popup will appear on the instrument cluster panel.
- If the target vehicle moves before 5 seconds, then host vehicle will resume itself. No user intervention is required here.



3. Warning behavior when Front Object is disappeared at low speed.

- When ACC is active and following a target vehicle moving at low speed (under 30kmph) and if target vehicle disappears,

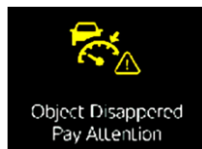

below warning will appear on instrument cluster panel. Here the vehicle speed will increase automatically to the minimum set speed (30kmph)

4. Warning behavior when front vehicle apply rapid brake.

- When target vehicle is shown in red color, user has to take over ACC system. The situation when ACC deceleration is insufficient due to rapid braking of preceding vehicle, the user must aware about this case and take control to apply enough braking.
- ACC will get deactivated and go to standby state when brake pedal is pressed.

5. Warning behavior when ACC is in Safety check mode.

- Safety message "Safety Check in Progress. ACC System Will be available in while" will be shown to user for 5 sec. During this mode ACC will be unavailable to user.

Feature Failure



When system fails due to some obstruction/blockage of front camera or radar then ACC feature may not work. In this case tell-tale may appear on instrument cluster and warning message will appear “Adaptive Cruise control System Failure Please contact authorized TATA service centre”.

To resolve this failure the user should clean the front camera or radar for any obstruction/blockage. If the issue still persists then turn Ignition OFF to ON. If the issue is still there then visit TATA MOTORS EV Authorised Service Centre.

System Limitation Scenarios

ACC system is subject to system limitations and may be unavailable or degraded performance in following situations.

1. Risk of collision in close cut-in.

- When vehicle is active with ACC and accelerating, if any vehicle comes immediately from adjacent lane, then there is risk of collision if the distance between subject and target vehicle is less.

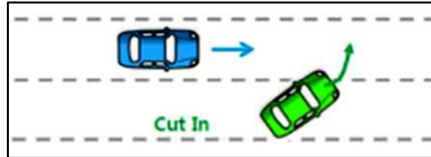

2. Risk of collision in close cut-out vehicle.

- When Host vehicle ACC is active and it is following a target vehicle, then if the target vehicle changes its lane and a stationary vehicle is present ahead in the host vehicle lane then there is a possibility of collision

with the new stationary target vehicle due to backlight glare or other camera limitation.

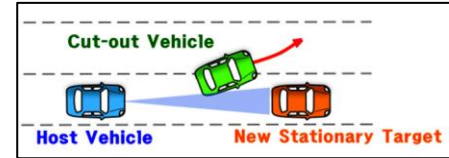

3. Risk of collision ignoring stopped vehicle.

- When Host vehicle ACC is active and it is following a target vehicle, then if the target vehicle changes its lane and a stationary vehicle is present ahead of that in the host vehicle lane then there is a possibility of collision with the new stationary target vehicle due to moving vehicle being recognized as the new target

STARTING AND DRIVING

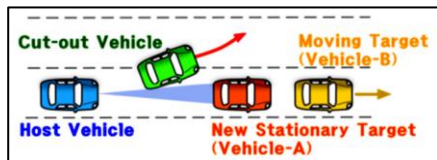

4. Risk of missing lane due to curvature entry/exit situation.

- ACC system predicts the lane curvature in driving appropriately. If curvature of the road differs from the predicted curvature, then adjacent lane can be selected as the host vehicle lane and target vehicle in the actual host vehicle lane can be missed. Alternately, a vehicle present in the adjacent lane can be detected as target vehicle.

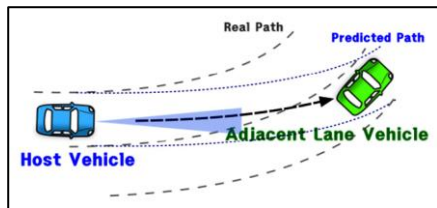

5. Risk of missing lane due to Excessive Curvature Curve.

- ACC system is designed to work with minimum curvature of around 125m. If the radius of curvature of the road is smaller than 125m, then an inadequate acceleration/deceleration can occur due to difficulty of detecting the inner lane.

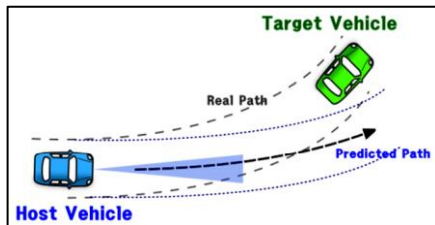

6. Risk of collision due to weather conditions.

- If the driver uses the ACC in the bad weather conditions (snow, rain, fog, etc.) or during low visibility situation, the sensor limit may cause a collision between the vehicle and pedestrians/Vehicle ahead.

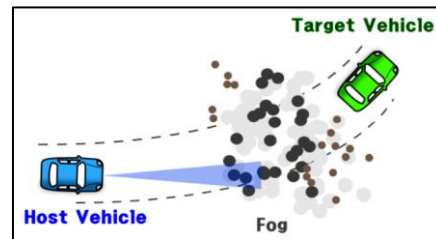

7. Risk of collision due to Intersection situation.

- If the vehicle ahead cuts out at the intersection, there is a possibility of collision with the transverse moving vehicle due to rapid acceleration of host vehicle.

STARTING AND DRIVING

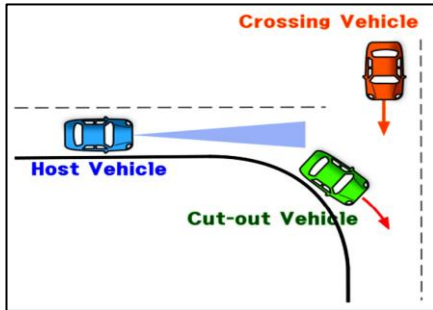

8. Risk of collision due to road gradient change.
- The target vehicle can be missed when crossing a section of road where the road gradient changes. For e.g. a hill or an underground road.

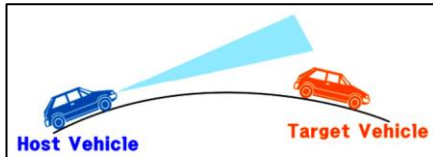

9. Risk of collision due to Sensor Blockage.

- In case front camera or radar is contaminated / blockage then collision of the front vehicle and pedestrians may occur.

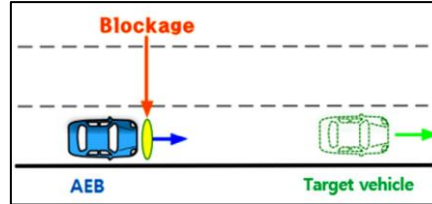

10. Special Vehicles / Vehicle with specific load

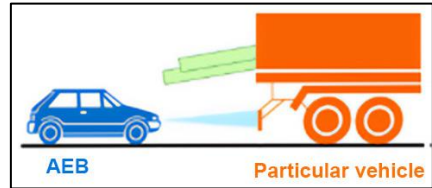

- When a specific type of load is loaded or a special vehicle, it can collide due to the sensor detection limitation.

11. Risk of collision due to excessive load of preceding vehicle.
- If the height of front preceding vehicle is very high, in such case sensor may not recognize the vehicle and collision may occur.

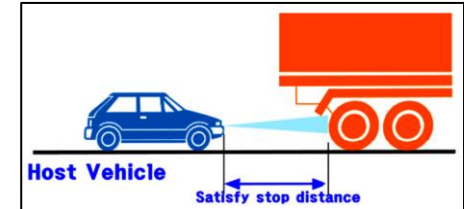

12. Risk of Collision due to inability to recognize the pedestrian.
- ACC system doesn't control people, especially if a pedestrian appears in front of the host vehicle during the Stop & Go situation, the host vehicle may collide with the pedestrian.

STARTING AND DRIVING

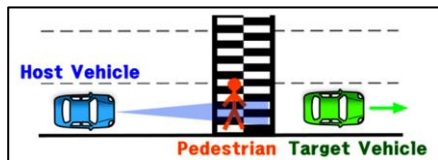

13. Risk of Collision due to excessive braking of the preceding vehicle.

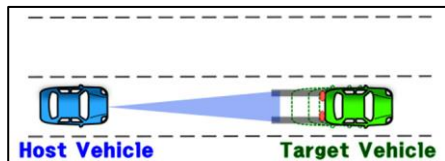

- When ACC system is active and vehicle is moving, if preceding vehicle applied sudden brake, then collision may occur.
14. Detection performance deterioration due to roadside structures.
- If a construction section, railroad track, or other metallic object is on the road (e.g., tollgate, subway construction site, tunnel, lane-proximity guardrail, etc.), this may affect the

detection performance and front vehicle may not be detected. This may cause the collision.

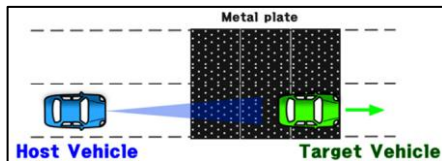

15. Takeover request if excessive braking applied by Preceding Vehicle.
- If the Preceding Vehicle brakes beyond the ACC maximum deceleration limit, Host vehicle might collide with target vehicle. In such case ACC Takeover Request warning displays on cluster to alert the Host vehicle Driver.

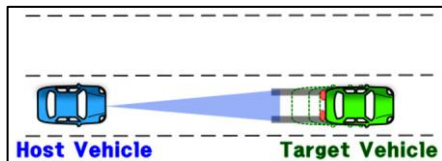

5. High Beam Assist (HBA)

High-beam assist recognizes headlamps of on-coming vehicle & tail lamps of leading vehicle in night condition switching headlights between high and low beam automatically

Prerequisite for activation

1. Front Camera should be fault and blockage free.
2. Front windshield should be clean.
3. HBA is ON in Infotainment Setting
4. Auto light mode is turned ON.
5. High Beam is ON.
6. Vehicle speed is more than 20 Kmph.

User Settings

HBA retains last user settings after every ignition ON.

User can turn HBA feature ON/OFF from Infotainment Settings

Go to Home page >> All App >> Settings >> Driver Assistance >> Drive assist

Feature Operation

Warning Behavior (When HBA ON)



When HBA feature is active tell-tale or icon shall appear in the instrument cluster in green color.

In this case, when an oncoming vehicle is detected, the system switches the High Beam to Low Beam. And when the vehicle is passed, then the Low beam is switched back to High Beam.

If High Beam is turned OFF due to bright streetlights, then once the streetlight location is crossed completely, High Beam may be turned back ON.

Feature Failure



If HBA system fails, then pop up message may appear in the instrument cluster along with tell-tale in amber color.

To resolve this failure the user should try cleaning the windshield camera of any obstruction/blockage. If the issue persists, then turn Ignition OFF to ON. If the issue is still there, then visit service centre.

Limitations of High Beam Assist

HBA is subject to certain system limitations and may keep High beam OFF for certain limitations and ON for few other limitation conditions.

- Operation at up/down hill.
- Operation at curve.
- If HBA fails due to any reason including vehicle head lamp fault.
- Unrecognized Front headlamp of oncoming vehicle.
- Unrecognized rear taillight.

- Construction area: For temporarily installed reflectors. There is a possibility of false recognition of temporarily installed reflectors.
- In the case of rainy weather: Water is left on the road after rain, and light from the light source is reflected. There is a possibility of misrecognition due to reflection of the light source.
- After detecting low beam from oncoming vehicle, HBA may give flash from low beam to high beam and again low beam due to any other light sources present around or due to camera detection performance.

Disclaimer

- If HBA detects the light sources of oncoming vehicle only for short period, HBA can stay in high beam without switching low beam.
- In the case that obviously appeared light sources of oncoming vehicle over the guardrail are detected, HBA may switch high beam to low beam.

STARTING AND DRIVING

- In the city or in a light source area such as traffic sign, electronic sign board, building light, streetlight, HBA may switch high beam to low beam.
- HBA shall not operate at daytime even though High Beam is on by the auto light sensor.
- HBA will operate in following weather conditions: The normal night time environment in which the light of the front vehicle is detected by the naked eye.

6. Traffic Sign Recognition (TSR)

Traffic Sign recognition (TSR) is a feature by which a vehicle is able to recognize the traffic signs available on the road.

Prerequisite for Activation

Front camera should be fault and blockage free

Front windshield should be clean

Vehicle speed is above 0 km/h

User Settings

TSR shall be default ON at the start of vehicle.

User can turn TSR feature ON/OFF from Infotainment.

Go to Home page >> All App >> Settings >> Driver Assistance >> Drive assist

Feature Operation



Sign is displayed in the instrument cluster when TSR recognizes the Speed Limit

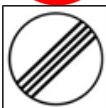

Sign is displayed in the instrument cluster when TSR recognizes the End of speed limit sign/End of restriction sign.



Sign is displayed in the instrument cluster when TSR recognizes the No Overtaking Allowed sign.

Feature Failure



If the system malfunctions, below tell-tale will appear in the instrument cluster and a pop up message "TSR System Unavailable. Please Contact Service Center" is shown on Infotainment screen.

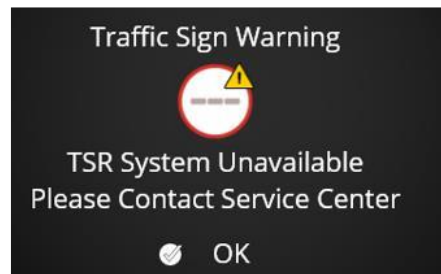

If the system Temporary Unavailable due to camera blockage, tell-tale will appear in the instrument cluster and a pop up message "TSR System Temporarily Unavailable. Please Contact Service Center" is shown on Infotainment screen.

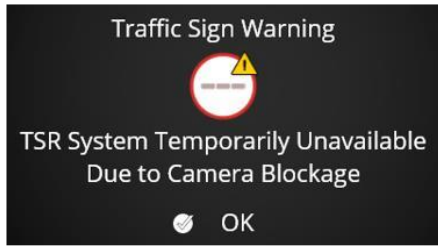

To resolve this failure the user should try cleaning the windshield camera of any obstruction/blockage. If the issue persists, then turn Ignition OFF to ON. If the issue is still there, then visit service center.

Limitations of TSR

TSR cannot recognize or it can misrecognize the signs on the road under some conditions. Those conditions are as follows

1. Day coarse conditions
 - In the case that the traffic signs cannot be distinguished due to shadow caused by overpass or trees.
 - In case of low sunlight, heavy rain and heavy snow.

- In case of traffic sign occluded by obstacle near road such as a tree, vehicle, etc.
 - In case of damaged traffic sign.
 - In case of poor visibility being impossible to recognize traffic signs.
 - In case of faded traffic sign.
 - In case of strong curve road
 - In case of multi-lane traffic signs may not recognized in third lane due to long distance.
2. Night coarse conditions
 - In case of poor illumination to the traffic sign caused by headlamp lighting angle.
 - In case of reflection from the traffic sign.
 - In case of heavy rain and heavy snow.
 - In case of traffic sign occluded by obstacle near road such as a tree, vehicle, etc.
 - In case of damaged traffic sign.

- In case of poor visibility being impossible to recognize traffic signs. In case of faded traffic sign.

Disclaimer

The traffic sign on road which is not as per Vienna convention may not get detected. TSR signs will be detected only when they fall in TSR system detection zone.

Following signs may not be detected in every case or at all:

- Non-standard signs which are not as per Vienna Convention
- Signs with yellow background
- Speed Limit signs ending in 5 like with 15, 25, etc.
- Speed limit signs having extra characters like kmph etc.
- Speed limit signs having extra images like small cars etc. Traffic signs will be detected only when they fall in TSR system detection zone within 10 Mtr.

STARTING AND DRIVING

7. Driver Dose off Alert System (DDOA)

The 'driver drowsiness detection' system monitors the behavior of driver on continuous basis and detects pattern of drowsy driver.

It monitors driving behavior, frequency of steering movement, driving pattern, time of the day and length of trip.

If the function reaches a threshold of the driving behavior it, then alerts the driver via voice alert and visual notification on the infotainment screen.

This feature helps in reducing accidents by giving prompt warning to the driver to stay awake or take a break.

Rear Advanced Driver Assistance System (Rear ADAS)

Rear ADAS features uses two rear corner radars, which will be placed on corners of the rear bumper of the vehicle.

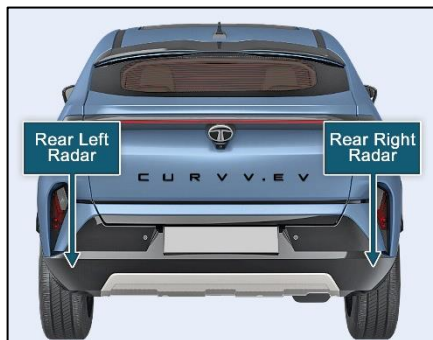

i NOTE

The correct operation of the rear corner radar sensors will be compromised if they are misaligned due to accident damage at the rear of the vehicle.

*If any damage to rear bumper of the vehicle, it is recommended to get the vehicle

inspected by TATA MOTORS EV Authorised Service Centre.

Rear ADAS Malfunction



1. When outside rear view mirror warning light is not working properly, the "ORVM indicator failure. Rear ADAS feature Impacted. Please contact service center" message will appear on the cluster for several seconds

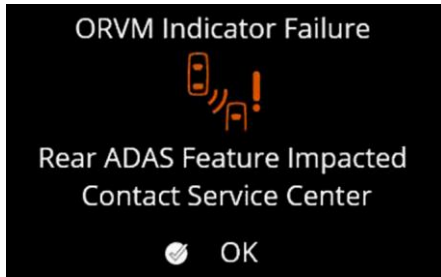

*In this case, it is recommended to get the vehicle inspected by TATA MOTORS EV Authorised Service Centre.

*Please make sure the warning indicators in the ORVM's are not obscured by stickers or any other objects.

Rear ADAS Features

8. Blind Spot Detection - Lane Change Alert (BSD-LCA)

BSD-LCA detects moving objects present in the adjacent lanes and warns if there are moving objects present in blind spots of the host vehicle or there is a high speed closing vehicle in adjacent lanes. Warning to the driver is given in stages.

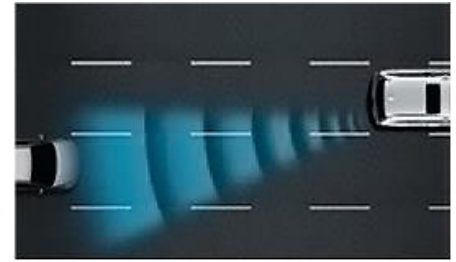

Prerequisite for activation

The following condition shall be satisfied to activate BSD-LCA

1. Rear Corner Radars and other related systems are fault free.
2. Vehicle shall be in Drive (D) or Neutral (N) Mode.
3. Vehicle speed is above 20 kmph approximately.

User Settings

1. BSD-LCA will be default ON during start of vehicle i.e. on every Ignition ON the BSD-LCA feature will be enabled even if previously disabled.
2. User can turn ON/OFF BSD-LCA feature using infotainment screen.

STARTING AND DRIVING

Go to Home page >> All App >> Settings >> Driver Assistance >> Drive assist.

Feature Operation

When the conditions for BSD-LCA warnings are met for an object in BSD-LCA zone, The warning indicator on the outside rear-view mirror will illuminate as follows:

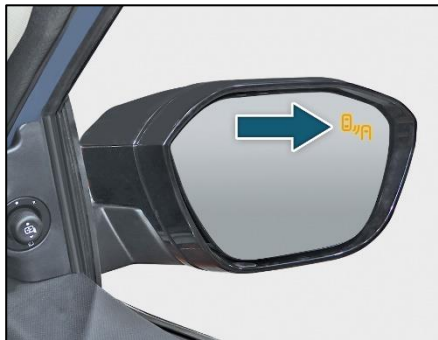

Level 1 Warning: (Object detected in the BSD-LCA zone): The warning light on the ORVM will be continuously ON.

Level 2 Warning: (Object detected in the BSD-LCA zone and Turn signal ON-same

side as where object is detected): - The warning light on the ORVM will blink along with audible warning. If turn indicator is switched OFF level 2 warning will be deactivated.

*i*NOTE

Audible warnings are not repeated until the collision threat visual alert disappears.

Feature Failure



When BSD-LCA is not working properly, the “Blind spot detection system failure. Contact service centre” message will appear along with tell-tale on the cluster for several seconds.

When rear corner radar is covered with any material which will influence BSD – LCA working, the “Blind spot detection system temporarily unavailable. Contact service centre” message will appear along with tell-tale on the cluster for several seconds.

*If any of these malfunctions occurs, it is recommended to get the vehicle inspected by TATA MOTORS EV Authorised Service Centre.

Limitations of BSD-LCA

- When the hazard-warning indicator is ON, the Level 2 BSD-LCA warning by the turn signal shall not operate.
- BSD-LCA may not function properly, when the speed of the other vehicle is more, as it passes by your vehicle in a very short time.
- Your vehicle passes by the other vehicle at very high speed.
- Your vehicle changes lane without giving turn indicators.
- The vehicle in the next lane moves two lanes away from you, or when the vehicle two lanes away moves to the next lane from you.
- When your vehicle overtakes other vehicle and relative speed between the two vehicles is low.
- When your vehicle is braking.

- When your vehicle is moving in scenarios such as sharp turns, junctions, roundabouts, etc.
- When driving on a curved road as, the function may not detect the vehicle in the next lane.
- The function may recognize a vehicle in the same lane.
- While driving on the road merges or divides. The function may not detect the vehicle in the next lane.
- When driving on a slope. The function may not detect the vehicle in the next lane.

Disclaimer

Since the detecting range of the rear corner radar is determined by a standard road width, therefore, on a narrow road; BSD-LCA may detect other vehicles two lanes over and warn you. On the other hand, on a wide road, BSD-LCA may not be able to detect a vehicle driving in the next lane and may not warn you.

9. Rear Cross Traffic Alert (RCTA)

RCTA system warns the driver while reversing out of a parking spot or where there can be a possibility of a collision with a vehicle or an object crossing sideways from behind.

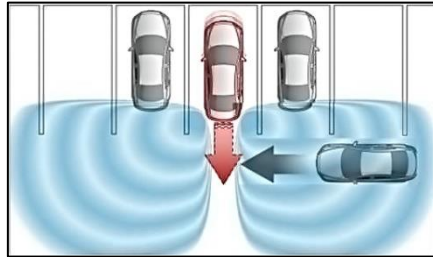

Prerequisite for activation

The following condition shall be satisfied to activate RCTA

1. Rear Corner Radars AND other related systems are fault free.
2. Ignition shall be in ON state.
3. The R (Reverse) mode engaged.
4. Vehicle speed is below 8Km/h approximately.

User Settings

1. RCTA shall be default ON during start of Vehicle i.e. on every Ignition ON the RCTA feature will be enabled even if previously disabled.
2. User can turn ON/OFF RCTA feature using infotainment screen.

Go to Home page >> All App >> Settings >> Driver Assistance >> Drive assist.

STARTING AND DRIVING

Feature Operation

When the conditions for activating the RCTA warning are met for any object in RCTA zone,

1. The warning indicator on the outside rear-view mirror will blink if an object is recognised in RCTA zone

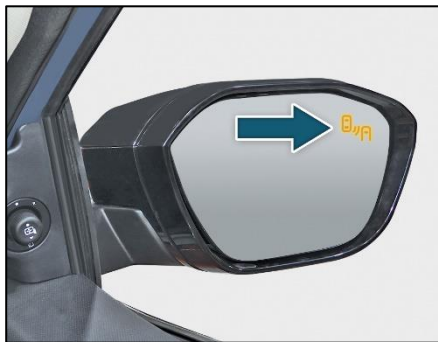

2. A warning icon (direction specific) will appear on the infotainment screen.

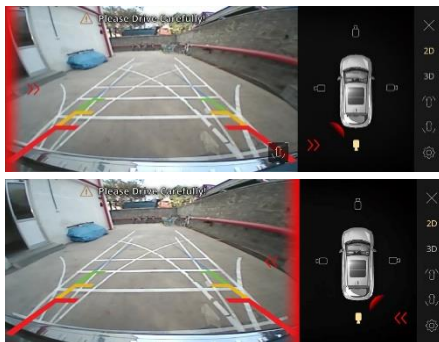

3. At the same time, an audible warning will sound.

Feature Failure



When RCTA is not working properly, the “Rear cross traffic alert system failure. Contact service centre” message will appear along with icon on the infotainment screen for several seconds.

When Rear corner radar is covered with any material which will influence RCTA working,

“Rear cross traffic alert system temporarily unavailable. Contact service centre.” message will appear along with icon on the infotainment screen for several seconds.

*If any of these malfunctions occurs, it is recommended to get the vehicle inspected by TATA MOTORS EV Authorised Service Centre.

Limitations of RCTA

- While reversing near an obstruction (like vehicle or structure): RCTA may not warn the driver when reversing near a vehicle or structure and may not detect the vehicle approaching from the left or right.
- RCTA may provide degraded functionality when the vehicle is on a slope (uphill/downhill) or near it. In this case system may not warn the driver.

Disclaimer

- While reversing out of complex parking situations: RCTA may or may not give the warning or may operate unexpectedly in the situations where other vehicles are parking or coming out of parking near your vehicle.
- When your vehicle is parked diagonally:
 - RCTA may provide limited functionality when coming out of diagonal parking space and may not detect vehicle approaching in RCTA zone.
 - RCTA system may operate unexpectedly during complex diagonal parking situations (like slow moving vehicle coming very close, vehicles parked in adjacent very closely etc.)
- RCTA may detect vehicles in front of you while parking reverse into a space with a wall or structure in rear/side area. In this case system may provide unnecessary warning.
- RCTA may not operate properly, or it

may operate unexpectedly when the approaching vehicle is very fast or very slow.

- RCTA may operate unexpectedly in case of heavy traffic when multiple other vehicles are approaching from both sides.

10. Door Open Alert (DOA)

DOA system warns the passengers in the car about the presence of approaching vehicles from behind which may hit the door while opening the respective side door.

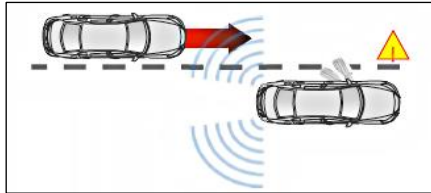

DOA

*i*NOTE

Door Open Alert is an aid system only. It is the responsibility of the user to open the door with due attention, in a

way which is safe for the vehicle, and other road users, so that serious injuries can be avoided.

Prerequisite for activation

The following condition shall be satisfied to activate DOA

1. Rear Corner Radars and other related systems are fault free.
2. Vehicle speed is below 3 km/h approximately.
3. Ignition is ON and approximately for 3 minutes after ignition is turned OFF, but turns off immediately if the vehicle is locked externally.

User Settings

1. DOA shall be default ON during start of Vehicle i.e. on every Ignition ON the DOA feature will be enabled even if previously disabled.
2. User can turn ON/OFF DOA feature using infotainment screen.

Go to Home page >> All App >> Settings >> Driver Assistance >> Drive assist.

STARTING AND DRIVING

Feature Operation

When the conditions for DOA warnings are met for any object in DOA zone,

1. The warning indicator on the outside rear-view mirror will illuminate as follows:

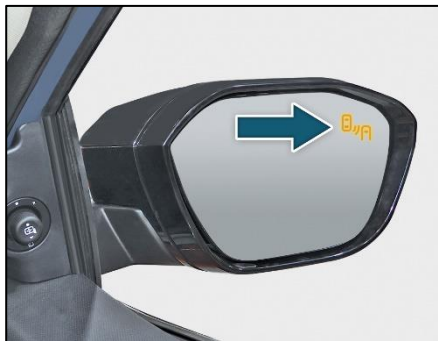

Level 1 Warning (Object detected in the zone): The warning light on the ORVM will be continuously ON.

Level 2 Warning (Object detected in the zone and respective side door opened): The warning light on the ORVM will blink

along with audible warning on the cluster as shown below.



Feature Failure



When DOA functionality is not available, the “Door open alert system failure. Contact service centre” message will appear along with icon on the cluster screen for several seconds.

*If this malfunction occurs, it is recommended to get the vehicle inspected by TATA MOTORS EV Authorised Service Centre.

Disclaimer

Door open alert may not operate properly, or it may operate unexpectedly when the approaching vehicle is very fast or very slow or in cases where the approaching vehicle is at certain angles.

11. Rear Collision Warning (RCW)

RCW identifies potential collision risks from the back of the vehicle. The system warns the driver of the rear vehicle of identified collision risks by automatically flashing the hazard lights of your vehicle.

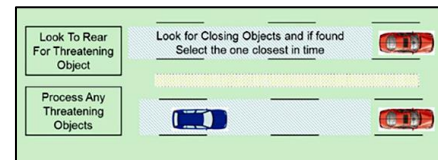

iNOTE

Door Open Alert is an aid system only. It is the responsibility of the user to open the door with due attention, in a way which is safe for the vehicle, and other road users, so that serious injuries can be avoided.

Prerequisite for activation

The following condition shall be satisfied to activate RCW

1. Rear Corner Radars and other related systems are fault free.

2. Vehicle shall be in Drive (D) or Neutral (N) or Park (P) mode.
3. Vehicle speed is within system operating limit in Drive (D) mode.

User Settings

1. RCW shall be default ON during start of Vehicle i.e. on every Ignition ON the RCW feature will be enabled even if previously disabled.
2. User can turn ON/OFF RCW feature using infotainment screen

Go to Home page >> All App >> Settings >> Driver Assistance >> Drive assist.

Feature Operation

In case of RCW warning, all right and left direction indicators will flash to warn driver of vehicle in behind about a possibility of collision.

Feature Failure

- When RCW is not working properly, the “Rear Collision Warning system failure. Contact service centre” message will appear on the cluster for several seconds.

- When Rear corner radar is covered with any material which will influence RCW working, the “Rear Collision Warning system temporarily unavailable. Contact service centre” message will appear on the cluster for several seconds.

*If any of these malfunctions occurs, it is recommended to get the vehicle inspected by TATA MOTORS EV Authorised Service Centre.

Limitations of RCW

- When target is overtaking from left lane to right lane, RCW system may not trigger warning.

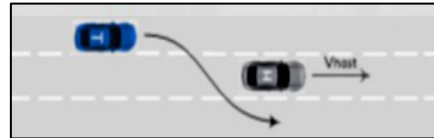

- When target is overtaking from right lane to left lane, RCW system may not trigger warning.

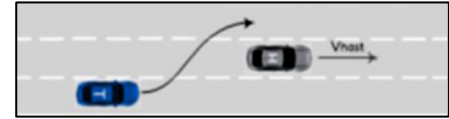

Disclaimer

- In curved roads, RCW system may trigger warning inconsistently.
- RCW warning may not be triggered in case of lane merges or the rear vehicle is approaching at an angle.
- The system may not operate properly when your vehicle is moving in scenarios such as sharp turns, junctions, roundabouts, etc.
- The system may not operate when overlap of your vehicle and other vehicle is small.

STARTING AND DRIVING

ACOUSTIC VEHICLE ALERTING SYSTEM (AVAS) (if equipped)

EVs are almost silent while moving, making it challenging for pedestrians to recognize when a car is coming. Sound generators called acoustic vehicle alerting systems (AVAS) are installed in electric vehicles (EVs) to notify/alert the pedestrians.

AVAS unit is placed in front under the bonnet.



Charging sound

If turned on by user, AVAS informs user with a sound intimating vehicle charging is started & ended.



Lock and Unlock Sound

If turned on by user, AVAS informs user about vehicle lock and unlock in limited scenarios.

V2X sound

If turned on by user, AVAS informs user with a sound intimating vehicle discharging is started/ended.



CLIMATE CONTROL

Air Distribution

The Climate Control regulates the temperature inside the vehicle and filter the dust particles in cabin based on the user set temperature settings. The air is distributed through the vents in the passenger compartment as shown below:

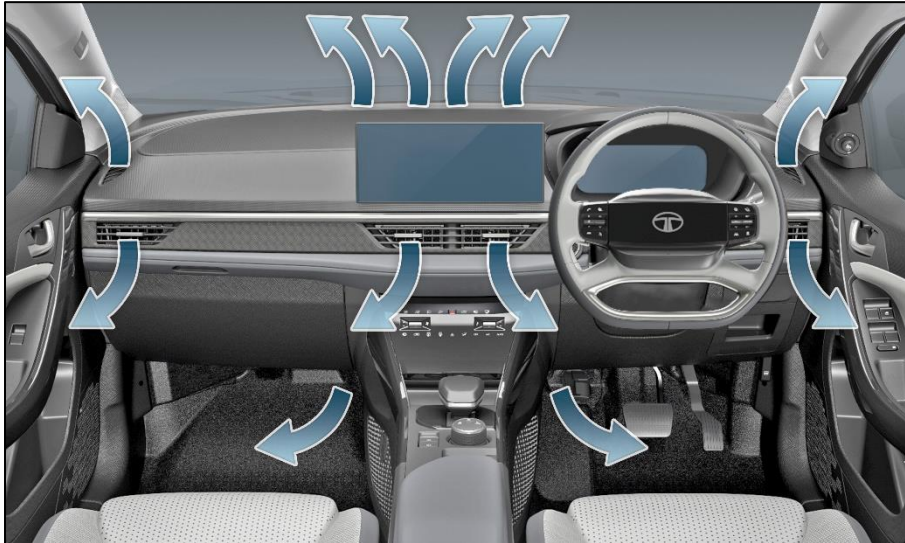

INTERIOR AND EXTERIOR FEATURES

Air Vents

Dashboard Side and Front Centre Vent

Air vents are available on the dashboard. The direction of air flow can be adjusted using sliders on the respective vents.

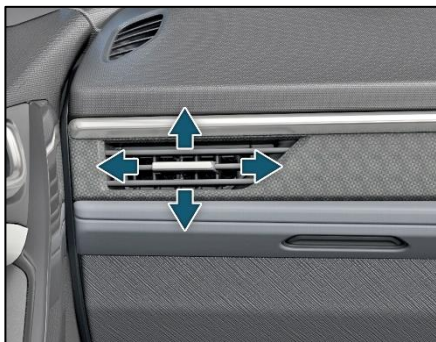

Dashboard Side Vent



Front Center Vent

Rear AC Vent

Rear AC vents are available between two front seats. It can be switched 'ON' provided that front AC is switched 'ON'.

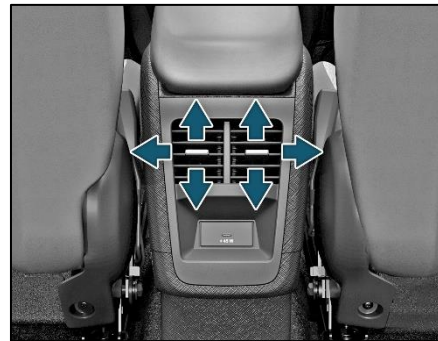

FULLY AUTOMATIC TEMPERATURE CONTROL (FATC) (if equipped)

FATC system controls the in-cabin temperature of the vehicle automatically and provides maximum passenger convenience regardless of outside weather conditions.

Display Unit



1. Blower control toggle switch
2. Xpress cooling
3. Fresh air / recirculation
4. Rear window demister
5. Maximum defrost

6. In car Sensor
7. Air distribution (mode)
8. OFF mode
9. AC ON/OFF
10. Auto ON selection
11. Temperature control toggle switch

Display Screen



FATC display is shown on main display screen.

FATC functions can be controlled using both the FATC control panel and the touch screen display.

Whenever the user selects any switch or moves the toggle switch, then the display unit will show the relevant climate information

Also, when the display is not in climate

mode then climate information will be displayed on the all-time display available on the top bar and widget.

Blower control toggle switch



Move the temperature control toggle switch up to increase the temperature of the air. The desired temperature will be increased by steps of 0.5°C. User can select temperature range from 18°C to 30°C. Move the toggle switch down to reduce the temperature. When you set the temperature to its lower limit (LO) or its upper limit ((Hi), the system runs at full cooling or heating only. It doesn't regulate the interior temperature.

Xpress Cool



XPRESS Cooling can be turned ON/OFF by selecting XPRESS COOL icon. This

INTERIOR AND EXTERIOR FEATURES

helps cabin to reach to comfort temperatures quickly by optimally setting the air conditioning to maximum cooling. Also, if required, the driver window will roll down to flush the hot air from inside the cabin. Once cabin has been sufficiently flushed, the system will announce to take driver window's roll up which can be taken up using window winding switch.

Driver side window may roll down, if:

- The cabin temperature is more than outside temperature.
- If it is not raining.
- Vehicle Speed is less than 40 kmph.

Further, after sufficiently cooling the cabin, the Xpress cooling function will auto switch off and revert back to customer pre-selected settings.

Xpress cooling functionality is used to improve the HVAC system performance in case of cabin temperature being considerably greater than outside air temperature. The system will be deactivated automatically after 500 sec of continuous operation.

NOTE

The Xpress Cool function can only be turned ON if the Ambient temperature is above 18 degree Celsius.

Fresh Air / Recirculation



1. When the recirculation switch is turned ON, air from the vehicle's interior is sent throughout the system.
2. When the recirculation switch is turned OFF, air from outside enters in to the cabin (fresh mode). Whenever discomfort is felt, switch to fresh air mode.

NOTE

The outside air intakes for the climate control systems are at the base of wind- screen. Keep this area clear from leaves and other debris.

Use recirculation mode for faster heating and cooling. However, keeping the system in recirculation mode - particularly when the AC is in OFF - can cause fogging of windows

Rear Window Demister



Select the rear window demister switch to turn it ON or OFF. The system will be deactivated after 15 min of continuous operation.

Maximum Defrost



1. It directs the main airflow towards windscreen for faster defrosting. (It also overrides any mode selection you may have made).
2. When you turn off the maximum defrost, the system returns to its former settings.

INTERIOR AND EXTERIOR FEATURES

NOTE



For your safety make sure you have a clear view through all the windows before driving.



Air Distribution (mode)



In AUTO mode, the FATC system will regulate the mode automatically. However, user override is possible with the use of MODE switch to select the desired airflow mode.

Each time you select the MODE switch, the display shows the mode selected.

	Directs air through the center and side air vents
	Directs air through the center, side and foot well vents

	Directs air through the foot well air vents
	Directs air through the defroster & foot well vents (Default fresh air mode)
	Directs air through the defroster vents (Default fresh air mode)

OFF Mode



Select the OFF switch to turn the system 'OFF'. OFF will be displayed on the infotainment screen.

AC ON / OFF



Select the AC ON/OFF switch to turn the air conditioning ON or OFF. The AC icon activated on the display when the AC is ON.

Auto ON Selection Button



To put the automatic climate control in fully automatic mode:

1. Select the 'AUTO' switch.
2. Set the desired temperature by toggle switch. The display will show all the functions during 'AUTO' mode.
3. The system automatically selects the proper mix of conditioned and / or heated air that will, as quickly as possible, raise or lower the interior temperature to your preference.
4. When you set the temperature to its lower limit (LO) or its upper limit (HI), the system runs at full cooling or heating only. It does not regulate the interior temperature.

INTERIOR AND EXTERIOR FEATURES

NOTE

In 'AUTO' mode, the FATC system will regulate the blower speed automatically.

Semi-automatic Operation

You can manually select various functions of the climate control system when it is in fully automatic mode. All other features remain automatically controlled. Making any manual selection causes the word 'AUTO' in the display to go OFF and the overridden setting is displayed. System will remain in semiautomatic mode till 'AUTO' is selected again.

INTERIOR AND EXTERIOR FEATURES

FATC SENSORS

Solar Sensor

FATC system is fitted with three sensors. (if equipped) Solar sensor is on the top of the dash-board at the right hand side of defroster grill.

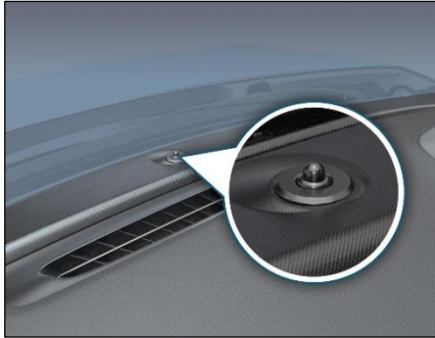

Outside Ambient Temperature (OAT) Sensor

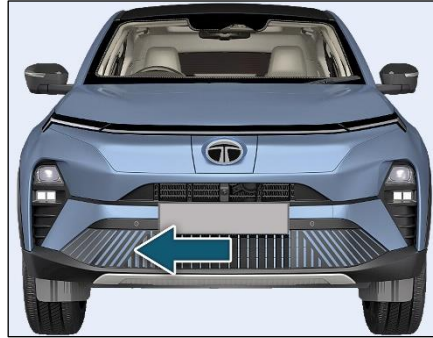

Outside Ambient Temperature (OAT) sensor located under the front bumper grill.

In-car Sensor on Control Panel

In-car sensor is located on FATC control panel.

*i*NOTE

- Do not cover or spill any liquid on sensors.
- Do not cover sensor, this may cause the sensor to malfunction. This may lead to FATC not functioning to desired level.

INTERIOR AND EXTERIOR FEATURES

CABIN AIR PURIFICATION

The Climate Control System fitted with advance filter for cabin air purification.

*i*NOTE

Replace the Filter as per Maintenance schedule. More frequent filter replacement are required/ recommended in case of vehicle is driven in heavy dusty conditions. If the vehicle is driven in heavy dusty conditions more frequent filter replacement are required. Replace the filter if you find poor ventilation, cooling or Demisting and poor Air Quality Index (AQI).

Air Quality Index : (If equipped)

- Climate control system fitted with FATC calculates Air Quality Index(AQI) of cabin using PM2.5 AQI Index.
- FATC System in AUTO Mode automatically sets the blower speed and switches to recirculation air mode to improve AQI inside the cabin.

- The calculated AQI is displayed on display unit along with severity index.



*i*NOTE

- AQI calculation will be effective after 30 secs, ignition ON and no value will be displayed during this period.
- If AQI does not improve in sometime get sensor and Cabin filter inspected.

FASCIA SWITCHES



1. Charger flap opening
2. Charging gun lock/unlock
3. Front Fog Lamps (If equipped)
4. Hill Decent control switch
5. Hazard warning switch
6. Tail gate opening
7. Central lock/unlock
8. Surround View System (SVS)

1. Charger Flap Opening

To release the charging flap, press the switch located on fascia switch

2. Charger Gun Lock/ Unlock

To release the charger gun, press the switch located on fascia switch. Charging socket inlet is located on front bumper

NOTE

Make sure both AC slow charging & DC fast charging is De-energised / off state.

3. Front Fog Lamps (if equipped)

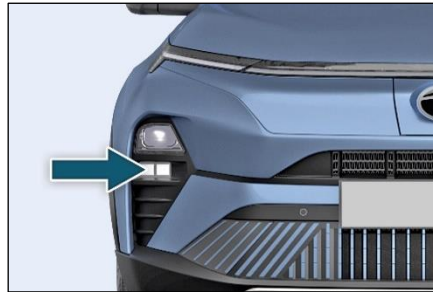

The front fog lamps are located on the front bumper. In poor visibility conditions due to fog, snow or rain, the fog lamps make visibility better and make it easier for other road users to see you. It turns to

'ON' when the fog lamp switch is turned on when the ignition is 'ON' and when the position and parking/ head lamp is 'ON'. An indicator on front fog lamp knob will come on when the front fog light is 'ON'.

4. Hill Decent control switch

While driving down on a hill slope, activate the HDC feature by pressing this switch.

5. Hazard Warning Switch

Press the hazard warning switch to activate the hazard warning. All the turn signal lamps will flash simultaneously. To turn OFF, press the switch again.

6. Tail Gate Opening

To unlatch the tail gate, press the switch located on fascia switch.

7. Central Lock/unlock

To open the door, press the Lock/unlock door switch located on the fascia switch.

8. Surround View Camera (SVS)

Press this switch to see the 360°view in the display screen.

INTERIOR AND EXTERIOR FEATURES

POWER SUNROOF (if equipped)

It brings natural light and fresh air into the passenger compartment. The cabin becomes more illuminated and bright, which gives a pleasant feeling while driving and makes the driving experience more enjoyable and relaxed.

Sunroof allows air to flow evenly from the roof, which is quieter and less intrusive than wind blowing through a side window. Sunroof can be operated by Manual Switch, Voice Command, and by Rain Detection/Vehicle Lock.



Manual Switch

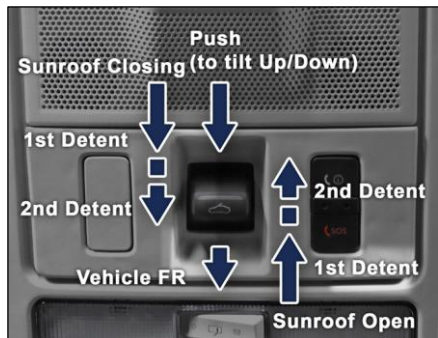

This switch is used to open, close, tilt up & tilt down the sunroof as and when required with switch intended operation.

1. Pull the knob away from the windshield to open the sunroof. It will be having two detents.
 - 1st detent Manual (long press) to open and stop at desired position.
 - 2nd detent Express (one touch) to open Sunroof completely.

2. Push the knob towards the windshield to close the sunroof. It will be having two detents.
 - 1st detent Manual (long press) to close and stop at desired position.
 - 2nd detent Express (one touch) to close Sunroof completely.
3. Press at the center of the knob for tilt up/down function. Sunroof switch mounted in overhead console near roof lamp.

Sunshade Open Position



INTERIOR AND EXTERIOR FEATURES

Sunshade Close Position



Sunroof Voice Command

Ensure vehicle is in IGN ON/running condition.

- Enable voice recognition via steering wheel switch or TATA Assist icon from the infotainment screen.



- System will be prompted with “How can I help?”
- Give the “sunroof open/close” command. Sunroof will be opened/closed.



Warning for Voice Command

- Speak the commands /Instruction in a neutral English accent for best results.
- Do not take long pauses (greater than 1 second) while speaking the words in a command. Speak the words of the command at a constant rate.
- Avoid varying your pitch and volume while speaking the commands. Speak clearly and loudly at a reasonable speed.
- Ensure that there is no noise disturbance when you speak the commands like, other passengers in the vehicle are talking or there is lot of wind noise. Disturbance from external sound sources may result in poor voice recognition.
- Always face forward while speaking your commands as the voice recognition quality is best in this orientation.

INTERIOR AND EXTERIOR FEATURES

Sunroof Closure on Auto Detection of Rain/vehicle Lock

For User Convenience / Protection of vehicle, sunroof will automatically close under following conditions:

- Rain Detection: When sunroof is open and rain is detected (based on Wiper speed is slow/high upon raining), then Sunroof will close automatically
- Vehicle Locking: The sun roof will close automatically when ignition is off and vehicle is locked from out through driver door manual key or by remote key.

NOTE

Combi Switch should be in auto mode to close sunroof with rain sensor.

Automatic Reversal / Anti-pinch Function



If the sunroof senses any obstacle while it is closing then it will reverse its direction and opens the sunroof so that trapped object will get released easily. The auto reverse function may not work if very thin or soft object is caught between the sunroof assembly. Anti-Pinch/ Automatic reversal is a safety feature however to override it and operate sunroof manually, press sunroof close switch within 10 seconds of auto-reversal completion and hold it till sunroof is fully closed.

WARNING

Never try pinching of any part of your body intentionally to activate the Automatic reversal function.

The Automatic reversal function may not work if something gets stuck just before the sunroof fully closes.

Warning for Sunroof

Even though the sunroof can be operated when the ignition key is in the ON position (the vehicle is not running), operating the sunroof repeatedly with the vehicle turned off will run down the battery. Operate the sunroof while the vehicle is running

When a desired sunroof operation is completed, release the switch. If you keep pressing the switch, it could cause a malfunction. Especially in winter, never operate the sunroof if moving areas are iced. Wait until the areas are de-iced.

Make sure head, hands, arms or any other body parts or objects are out of the way before operating the sunroof. Body parts or objects may get pinched causing

injuries or vehicle damage. Never deliberately use your body parts to test the automatic reversal function. The sunroof glass may reverse direction, but there is a risk of injury. Dust accumulated between the sunroof and roof panel can make noise or cause any damage. Open the sunroof and re-move dust regularly using a clean cloth. Do not sit on the top of the sunroof. It may cause injury or vehicle damage. Do not allow passengers to lean out of an open sunroof whilst the vehicle is in motion. Injuries may occur from objects such as tree branches. Safety of the vehicle occupants must be observed at all times. Do not allow limbs to be placed in the moving path of the sun-roof at any time, injury may occur.

WARNING

High Pressure wash Jet Flow should not be directed on Sunroof sealing area around periphery of glass. Doing so may lead to water leakage inside cabin.

Initializing the Power Sunroof

In the event of a power failure or while replacing the dead fuse or battery disconnection when the sunroof is in motion, then sunroof will require initialization when the power is restored.

Initializing Procedure

1. Turn ON the ignition.
2. Close the sunroof fully by pressing 'sunroof close switch' and keep the switch pressed for 1-2 seconds after the roof is fully closed, till clicking sound comes from Sunroof.
3. The Initializing command is complete, Check if the Express open/close features are working.

B-call and E-call Switch (if equipped)

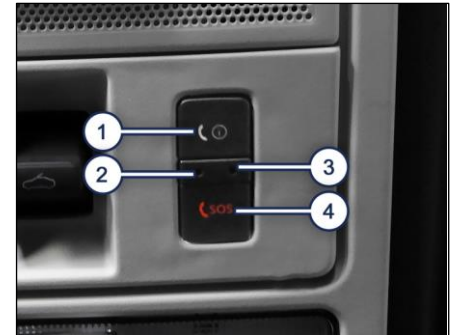

1. **B-Call Switch:** B-Call (Breakdown Assistance) will connect you to a TATA MOTORS Roadside assistance for Towing. Not for ambulance service.
2. **Red LED Indication:** Red LED indicates the fault or failure in B-Call/E-Call functionality.
3. **Green LED Indication:** Green LED indicates the status of ongoing B-Call or E-Call.

INTERIOR AND EXTERIOR FEATURES

4. **E-Call Switch (Emergency Call or SOS Switch):** E-Call will connect you to towing and ambulance services.

i NOTE

**Subject to mobile network, connectivity and location mentioned.*

STEERING MOUNTED CONTROLS (if equipped)

Steering Mounted Controls (LHS)

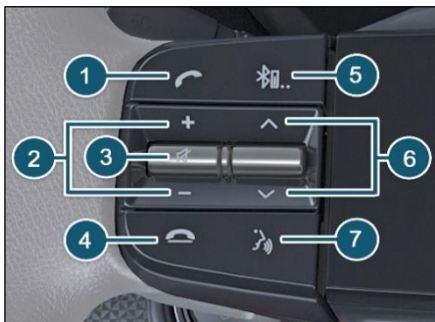

1. Phone Receive

Press above switch to accept incoming call when a cell phone is connected via Bluetooth.

2. Volume

Press above switch to increase or decrease volume of music system / radio.

3. Mute

For mute, press this switch. The system mutes/ pauses the currently played audio.

Press above switch to reject or hang up a phone call. It is also used to mute the volume of music system/radio

4. Phone Reject

Press the switch to reject or hang up a phone call.

5. Source

Press above switch to select the required source in the infotainment system i.e. USB, AM, FM and Bluetooth.

6. Seek Forward/backward

This will function in the two modes.

Radio Mode - will change radio channels.
Media Mode - will change sound tracks.

7. Push to Talk

For Voice Recognition, press this switch. The system mutes/ pauses the currently played audio and you will hear a beep sound to indicate the activation of the voice recognition feature. The system displays the voice recognition screen on Infotainment to indicate activation of the feature.

Master /force Restart Process

If your infotainment system touch screen becomes unresponsive or shows some unusual behavior, then you can restart it to potentially resolve the issue. Follow some basic steps given below and you can restart the system.

To restart the infotainment system



1. Park the vehicle.
2. Hold the Steering wheel Mute button (long press) (as shown in above image) for about 10 secs. Now hold the Steering wheel source

3. Now hold the Steering wheel source change button (long Press) for more than 10 sec) and release as soon as display's goes blank.

NOTE

- It is preferable to do one Ignition OFF to ON cycle after Master/Force restart to synchronize vehicle settings with the TATA Infotainment System.
- If the reboot does not work or master/force restarts are required on a weekly or daily basis, vehicle shall be taken to dealership. There, the dealer can update your firmware or inspect the system for hard-ware problem.
- Force/Master restart keeps the stored data, such as call history, text message information, and previously paired phones as it is.

Steering Mounted Controls (RHS)

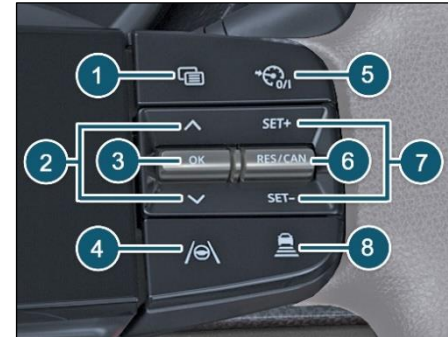

1. Pagination

Press the switch to enter in to cluster screen.

2. Page Up/down

If cluster screen is selected, with Up/Down switch you can access the sub-menu screens of a main menu.

3. Selection (OK)

Push the OK button to access/select the sub menu screens of a main menu item.

INTERIOR AND EXTERIOR FEATURES

4. Lane Keep Assist (if equipped)

Press the switch to activate the Lane Keep Assist function.

5. Cruise ON/OFF

Press the switch to turn ON/OFF the cruise function.

6. RES / CAN

To resume a previously set speed, push the RES button and release. This switch is also used to cancel /deactivate (CAN) cruise control system without erasing the set speed from memory.

7. SET+/ SET-

Accelerate the vehicle to desired speed, Press the SET + to select the required cruise speed. When the cruise control is set, you can increase or decrease the speed by pushing SET+/ SET- buttons respectively.

8. Adaptive Cruise Control (ACC) (if equipped)

Press the switch to activate the adaptive cruise control function.

Regeneration Switch

Regeneration is equipped in the vehicle, which converts the available kinetic energy during decelerating or braking condition of the vehicle to electrical energy which can charge the high voltage battery.

Regeneration level for the vehicle can be controlled manually or can be turned off. The Regeneration switch equipped behind the steering wheel assembly at both the sides Level Up and Level Down

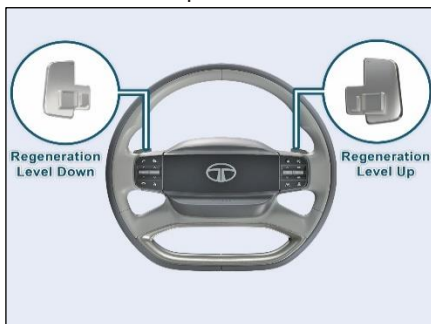

- By using the regeneration switch (Pull type) driver can Up/Down regeneration level.

- Level down switch can be used to reduce regeneration level (3 →2 →1→OFF)
- Level Up switch can be used to increase the regeneration level (OFF→1 →2 →3)
- Default regeneration level on the vehicle when vehicle is cranked will be Level 1.

Drive Modes	Default Regeneration
Sport	Level1
City	Level1
Eco	Level1

Drive Modes	Default Regeneration
OFF	No Regeneration
Level 1	Minimum Regeneration
Level 2	Intermediate Regeneration
Level 3	Maximum Regeneration

INTERIOR AND EXTERIOR FEATURES

INFOTAINMENT SYSTEM DISPLAY

Option I



Option II



MIC (if equipped)



Mic is provided near the roof lamp.

INTERIOR AND EXTERIOR FEATURES

SPEAKERS & TWEETER (if equipped)



Speakers and Tweeters are available in models with infotainment system. Provisions are given for music system and speakers on versions without infotainment system.

USB PORT (if equipped) Front USB A + C Charger



Rear C Charger



A type USB port is used to connect your portable digital music players, pen drives etc. for playing music tracks through the vehicle's music system.

C type USB port is used for fast charging of mobiles which are having C type interface.

INTERIOR AND EXTERIOR FEATURES

POWER SOCKET On Center Console



The power socket will work when the ignition switch is in the “ACC” or “ON” position. This socket can be used to provide 12V (10A) power for electrical accessories.

iNOTE

- *Use of unapproved electrical accessories can cause damage to your vehicle's electrical system.*
- *Make sure that any electrical accessories you use are designed to plug in to this type of socket and rating.*

LAMPS Roof Lamp

Interior roof lighting lamp is provided on the roof with inbuilt switch.



ON condition



The lamp will turn ‘ON’ as long as the switch is in this position.

DOOR condition



In this position the lamp turns to ‘ON’ when either of the doors are opened. When

the last door is closed, the lamp will turn ‘OFF’ with dimming. This helps settling in the seat and inserting the key in the ignition switch. When the key is turned to the ‘IGN’ position, the lamp goes ‘OFF’ immediately.

OFF condition



In this position, the lamp will remain ‘OFF’.

Boot Lamp



INTERIOR AND EXTERIOR FEATURES

Boot lamp is provided in the rear luggage compartment to illuminate the luggage area.

Whenever a door or tailgate is opened, it will turn ON.

Lamp Condensation / Fogging Condition

Condensation is a natural phenomenon in Lamp. This occurs mainly because of atmospheric condition/weather change. During normal condensation, thin film of mist is visible on the inside surface of the exterior lens. Generally, this condition is considered normal and will be eliminated by turning on the respective lamp with engine running or during normal driving conditions. By doing this if the condensation has begun to clear after the drying time it indicates that the lamp sealing has NOT been breached and will eventually clear. The lamp must NOT be replaced.

NOTE

- *All Exterior lamp fogging / condensation is natural occurrence and respective lamp assembly replacement will not necessary to resolve the issue.*
- *High-pressure washer jet direct on vent system of lamp are not recommended, there might be possibility*
- *Presence of condensation / mist in non-functional area is normal and acceptable, no action is recommended.*

ROOF GRAB HANDLE

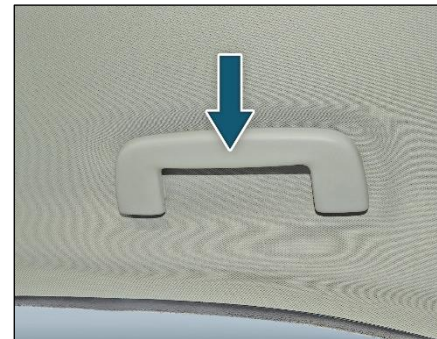

Grab handles are installed on the roof for all seats except for the driver's seat. These help the passengers to position themselves comfortably during the journey.

MOOD LIGHTS/AMBIENT LIGHTS (if equipped)

Ambient Light Function

Ambient lighting comforts user by illuminating the vehicle interiors at defined locations. Colored LEDs are fixed at various locations of the vehicle interiors.

Turning Ambient Lighting ON and OFF:

- Ambient lights turn ON in themes and color options (as per vehicle applicability) whenever parking light is turned to ON.
- Ambient lights turn OFF whenever parking light is turned to OFF.

Ambient Lights (entry/exit):

- Ambient lights turn ON in themes and color options (as per vehicle applicability) whenever roof lamp made active by removing the ignition key from key slot and opening any door.
- Once the opened door is closed, the ambient lights dims off after approximately 25 seconds.
- If door is left open, ambient lights

will turn OFF after set battery saver time.

Five Level Brightness Control

- Drag the slider to the right or left to adjust the brightness.

VEHICLE TELEMATICS (if equipped)

Car is equipped with iRA - Connected car Technology which offers a host of features to the users through the "iRA - Connected car" Mobile Application (APP). The Vehicle is equipped with an Electronic Control unit which monitors & records the data from various vehicle systems like Transmission, Brake, Battery & other electrical systems. This data is then processed & used for providing the connected Car features. (Refer the app tour section of the mobile app.)

The Connected Car module records the following information:

Vehicle Telematics

This includes the periodic transmission of data from other vehicle ECUs & Electronic systems like EMS, ABS, Air Bag, BMS, BCM etc. along with the geographical location of the vehicle.

Vehicle driving behavior

This includes the location, speed, acceleration, trip details, charging etc.

INTERIOR AND EXTERIOR FEATURES

Event based recording

This includes data generated during specific events like vehicle collision, intrusion, un-authorized entry etc.

The Data collected through Connected Car module is used by TATA Passenger Electric Mobility Limited for various purposes, including, but not limited to, providing connected car features through mobile APP.

- Evaluation of Vehicle performance.
- Research & improvement of current & future vehicle designs.
- Troubleshooting & diagnostics of the vehicle.

TATA MOTORS does not disclose the data recorded from your vehicle to any third party except:

- After obtaining a written consent from the Car Owner.
- Upon request from Law enforcing agencies and regulatory bodies.
- Used for research purpose without the Personal Verifiable information (anonymized).
- Used as defence of TATA MOTORS in a Lawsuit.

WIRELESS POWER CHARGING (if equipped)

WPC System Description

Wireless Power Charging (is a convenience feature to charge the smart mobile phone using wireless charging technology, without a need to plugin wire in the device.

The WPC system is powered with vehicle battery and the wireless power charging function is enabled with Ignition ON.

Qi Compatible Term

Qi 1.1.4: refers to certified product with the capability to transmit power of up to 15 W and detect metal and other impurities to prevent heating.

iNOTE

The WPC would support only those smart phones which are Qi compatible. Please refer to the smart phone manual or connect to smart phone manufacturer to check whether your smart phone supports Qi function.

Location of Wireless Charger

Location: The location of the WPC in vehicle is in the Centre console area as below.



Function of Each Component of WPC

Wireless Power Charging (WPC) ECU:

Generates power up to 15W and transfer power wirelessly by magnetic induction.

Anti-skid Mat: Holds the position of smart phone placed on it against any jerk and acts a charging contact surface for the smart phone.

INTERIOR AND EXTERIOR FEATURES

Cooling FAN: It is provided to keep charging surface temperature within ambient temperature range.

FAN Cover: It has ducts to direct FAN air on WPC ECU surface.

Infotainment unit: It is status display unit to display the status of wireless power charger. Status symbol and text display is displayed on Infotainment unit.

Functions of WPC System

A. Charging function: Charge smart phone

Following all the conditions are applicable in this feature to function correctly

Ignition ON (vehicle OFF)

Vehicle ON

Smart phone placed in correct orientation on the antiskid mat as below



WPC system detects the presence of phone and starts charging as per the Qi standard protocol. The charging status is updated and displayed on the head unit.

B. Charging Status display function:

1. WPC system in standby mode - WPC system is waiting for phone or phone is not getting detected by the WPC system etc. Customer is advised to check the Qi compatibility/phone alignment/any foreign object between the phone and mat.

2. Smart phone charging ON- Phone is charging
3. Metal object on the antiskid mat - Customer is advised to check any metal object on antiskid mat, if found, it is to be removed.
4. Smart phone battery is full/Charging completed
5. WPC ECU error ("Error" condition indicates abnormal operating conditions internal system fault or fan stuck/jam) - Customer should realign the phone to centre to initiate charging. if problem is not resolved you are advised to visit the TATA MOTORS EV Authorised Service Centre.



Metal Object Detected - Popup

INTERIOR AND EXTERIOR FEATURES



Metal Object Detected -All Time Display

Conditions to Charge Phone Properly

1. Keep the charging surface clear of any metal objects (coins, credit cards, smart cards, keys etc.)
2. Place the smart phone on the charging area marked for positioning the phone, for best results place the smart phone at the center of the charging pad.
3. Charge the smartphone without its cover or not a thick cover otherwise it would halt the wireless charging
4. Ensure that the phone is placed with display facing upwards and charging area touching the charging pad surface.
5. Turn ON the ignition to start the charging.

Information

- The wireless charging function is supported to charge smart phones which are Qi compatible. Certain features may not function as not supported by the smart phone manufacturer and not a malfunction of the wireless charging.
- Wireless charging stops with Ignition OFF.
- Wireless charging stops when the smart phone is not completely in touch with the charging pad surface or not positioned correctly on charging pad.

Do's and Don'ts



If any metal object such as coin is located between wireless charging pad and phone back, the charging may get disrupted. Also, metal object may heat up.

Do's:

1. Please ensure that the phone is compatible to the charging standard "Qi".
2. If any metal object found on charging pad remove it immediately.
3. In case of water/Liquid spillage on charging pad, dry out the pad surface area properly & clean the ECU surface area by removing Anti-skid mat. Do not charge the smart phone until surface is completely dry.
4. The smart phone may become hot while getting charged. Please be cautious about the high temperature while picking up the smartphone from the charging pad.

INTERIOR AND EXTERIOR FEATURES

5. Wireless charger works on principle of magnetic induction, i.e. it converts electrical energy into magnetic energy to transfer energy from charging pad to phone. Please maintain safe distance from the charger most of the time as it may cause irritation to sensory organs or active implants if implemented in the body. Please consult medical specialist in case implant organ in the body of the user
6. Always turn ON the IGN while using this feature to avoid vehicle battery drain issue.
7. Always keep charging pad clean and dust free.
8. Vehicle AC may turn ON during wireless mobile charging for efficient use of this feature.

Don'ts:

1. Do not use metal smart phone covers as it would halt the wireless charging function. The wireless charging may not function properly when there is a heavy & thick accessory cover on the smart phone.

2. Do not place smart phone up-side down on charging pad or do not miss aligned mobile phone on charging pad in such case smartphone charging will not happen.
3. Do not keep any metal objects like coins, smart keys, electronic cards e.g. credit card, debit card, smartcard from the charging pad as it may disrupt the charging process and/or may damage the card.
4. Do not keep any liquid (e.g. water, cold drink, and sanitizer), flammable object on antiskid mat.
5. Do not cover the wireless charger with a cloth or other object while charging. It may heat up the device and reduce the charging efficiency.
6. Do not disassemble, modify or remove the wireless charger & do not apply force or impact to the wireless.

Information

1. Small noise may be heard when a smart phone which does not support wireless charging or any foreign object is placed on the charging pad. This small sound is due to the vehicle discerning compatibility of the object placed on the charging pad. It does not affect the vehicle performance or the smartphone in any way.
2. For certain cellular phones with their own protection, the wireless charging speed may decrease and the wireless charging may stop.
3. When the interior temperature of the wireless charger rises above a set temperature, the wireless charging will cease to charging function. After the interior temperature drops below set threshold, the wireless charging function will resume.
4. When the mobile phone temperature rises above a set cut off threshold, the wireless charging will cease to charging function due to mobile phone stops demand power from wireless charger.

INTERIOR AND EXTERIOR FEATURES

5. After the mobile phone temperature drops below threshold, the wireless charging function will resume. Mobile temperature cut off threshold is much lower than WPC temperature cut off threshold.
6. When charging certain smart phones, the charging full message on head unit may not display when the smart phone is fully charged. It depends on smart phone manufacturer.
7. Smartphone of some manufacturers may display messages on weak current. This is due to particular characteristic of smartphone and does not imply a malfunction on wireless charger. Smaller smartphone users (ex. iPhone) may face intermittent charging issues due to its smaller size. (To avoid this, place the smartphone at center of the charging pad). Small mobile phones may not be able to charge in every position on charging pad.
8. The wireless charger may not operate correctly when the vehicle is near

a TV tower, electric power plant, gas station, large display, airport, or other facility that generates strong radio waves or electrical noise.

WPC ECU in Standby Mode

The infotainment system displays no warning message/ indication in this mode. This mode represents that the charging function is halted and not functional. The charging function could halt because of below reasons like:

1. Phone is not properly aligned with the charging pad or not positioned correctly on pad wireless charger in standby mode
2. Phone is kept in upside down position wireless charger in standby mode
3. Phone is fully charged, and phone does not demand power wireless charger in standby mode

Smart Phone Charging ON Mode

When the smart phone is placed correctly and the conditions are favourable to perform the function of wireless charging, the infotainment system shows following

messages. After Popup, The charging symbol stays ON until the phone is fully charged.

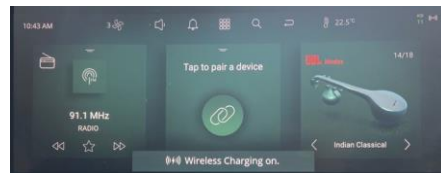

Charging Mode ON - Popup



Charging Mode ON – All Time Display

Metal Object Detection Mode

The charging gets interrupted/stopped due to metal object placed on the charging pad. The infotainment head unit displays following message. Check if there are any foreign objects between the smart phone and the charging pad, please clean if so. Smartphone shall be lifted for removing foreign objects and place it back on charging pad.



Metal Objects

NOTE

- *Delay in restarting of mobile charging will be observed if foreign objects are removed without lifting smart phone.*
- *After removing the foreign objects, if smart phone do not resume charging immediately lift the phone and place on charging pad to start the charging.*
- *In case, Phone overheat, remove and keep it after sometime.*

Smart Phone Battery is Full/ Charging Completed

The smart phone fully charged status is indicated on the infotainment display screen with following message. This Indication depends on phone profile whether it communicate the battery full charge status to WPC System.



Charging Complete Indication - Popup



Charging Complete Indication - All Time Display

INTERIOR AND EXTERIOR FEATURES

WPC System Error Mode

The error in the WPCF wireless power charger with FAN, system may cause the error message to get displayed on the infotainment screen.

Some of errors that can occur while charging which halt/interrupt charging can be covered with this indication are:

- WPCF internal fault which lead to permanent failure in charger functionality
- WPC Fan Stuck / Jam is detected
- Coil Failure
- High Temperature of WPC device (70 Degree C) Memory failure



System Error Mode- Popup

NOTE

If error message is pop up on head unit then avoid charging the smart phone and visit the nearby service station.

SHARK FIN ANTENNA

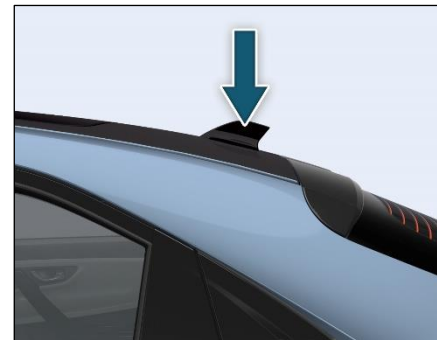

Shark FIN antenna is provided on the roof at rear end.



INTERIOR AND EXTERIOR FEATURES

WELCOME AND GOOD BYE STRATEGY

S.N.	Function	Vehicle Condition	Key Inputs	Lamp Animation
1	Welcome Animation	Lock	Unlock	A single flash of all direction turn indicators followed with a welcome animation of three cycles. Total animation time is approx. 4.5 Sec.
2	Goodbye Animation	Unlock	Lock	Two flashes of all direction turn indicators followed with a goodbye animation of three cycles. Total animation time is approx. 4.5 Sec
3	Second input Unlock	Unlock	Unlock	Single flash of all direction turn indicators.
4	Second input Lock	Lock	Lock	Four flashes of all direction turn indicators.

INTERIOR AND EXTERIOR FEATURES

For Animation

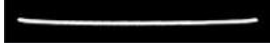
S.N.	Function	Animation	Lamp Animation
1	Buffering Animation		When charging is connected, the 20% battery state of charge band on the centre position lamp will gradually illuminate and will stay solid ON until charging commence.
2	Charging Animation		Once Charging is initiated, a single LED light bead will travel from inward to outward on centre position lamp, keeping the previous segment of battery state of charge solid ON, the animation will be played as per HMI user selected timing. Note- In case if there is delay in starting charging session after gun connection, charging animation will not be shown. However actual charging session of HV battery will continue as normal.
3	Charging Error		When a charging fault occurs, the 20% battery state of charge segment on the centre position lamp will blink for 30 seconds.
4	Battery Charge state 100%		When battery is fully charged, the complete centre position lamp will illuminate and will stay ON for 1 minute.

STOWAGE COMPARTMENT

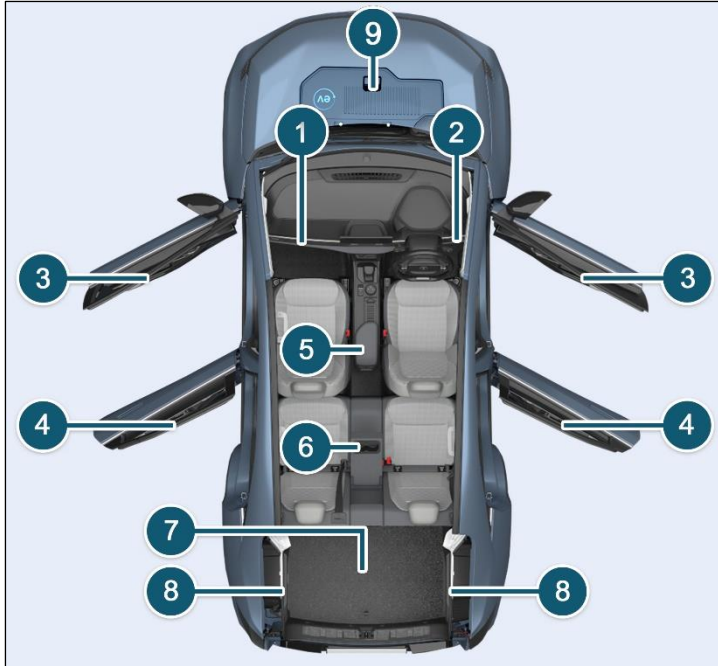

1. Glove box
2. Driver side coin box
3. Utility pockets on front doors
4. Utility pockets on rear doors
5. Center console below arm rest
6. Foldable arm rest/ Cup holder
7. Luggage Compartment
8. Utility Bin
9. Frunk

STOWAGE AREA

GLOVE BOX



Opening and Closing

To open- Press the knob and open the glove box flap.

To close - Lift glove box flap upward until it engages.

Glove Box Illumination

The glove box lamp illuminates when the glove box flap is opened.

NOTE

Make sure that glove box flap is closed while driving.

Stowage Detail

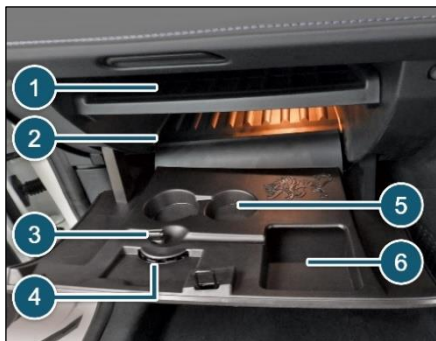

Following items can be stored in glove box.

1. Owner's manual and other vehicle document
2. Chiller glow box
3. Pen holder
4. Visiting card
5. Cup holder Receipts etc.
6. Receipts etc.

Cooling Facility (if equipped)



On selected models glove box is provided with a cooling facility. It cools the glove box only when the front A/C is ON. Shut OFF the vent by rotating the knob, whenever cooling is not required.

DRIVER SIDE COIN BOX



Stowage is provided on RH side of steering wheel for Coin, mobile and wallet.

UTILITY POCKETS ON FRONT DOORS



Utility pockets are provided on front doors and it can be used to keep following items.

1. Suitable water bottle
2. Suitable Umbrella
3. Magazine / paper / books

iNOTE

Remove the water from umbrella and fold it properly before storing it in umbrella holder.

UTILITY POCKETS ON REAR DOORS

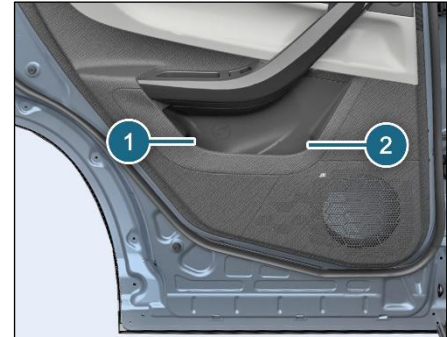

Utility pockets are available on rear doors and it can be used to keep following items.

1. Suitable water bottle
2. Magazine / paper / books

STOWAGE AREA

CENTER CONSOLE

Stowage below Arm Rest



Stowage compartment is provided below the foldable arm rest for keeping cell phones, iPod's, chargers etc.



Lift arm rest to open the stowage area.

FOLDABLE ARM REST (if equipped)

A foldable arm rest has been provided in the rear seat. It also has two-cup holders, which can be accessed by opening the cover. When not required, fold the arm-rest back into the seat.



iNOTE

Remove all items and cups before folding the cup holders. Use cups, containers, bottles of right size and which have lids. The content could otherwise spill.

LUGGAGE COMPARTMENT



Store the luggage in luggage compartment. You can keep suitcase, bags, etc.

WARNING

- Distribute the items of luggage as evenly as possible.
- Position heavy loads towards rear seat and low down in the trunk as possible.
- Do not allow occupants to travel in the luggage compartment.
- Do not place anything on luggage

cover as it could obstruct driver's rear view. Also in case of an accident or sudden braking, it could cause an injury to occupants.

Storage below Luggage Carpet

Store the suitable luggage below the luggage carpet in luggage compartment. It can be used to keep small items.

Utility Bin



Utility storage bin is provided on LH and RH side in luggage compartment.

STOWAGE AREA

HOOKS (if equipped)

Coat Hook

Coat hangers are provided for rear passenger on both grab handles.



iNOTE

- *The coat hook is not designed to carry heavy objects or luggage items.*
- *Do not hang hard, sharp-edged or fragile objects on the coat hook.*

Hook For Purse Holder



Hooks for holding purse are provided on both B pillar.

Collapsible Hook

Collapsible hook is provided for hanging small carry bags etc. Load up to 2 kg is permissible.

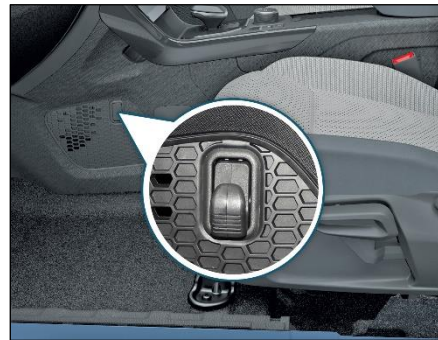

Carrier Hook in Luggage Compartment

Carrier hook is provided for hanging small carry bags etc. Load up to 3 kg is permissible.



iNOTE

Do not use these hooks for securing luggage like using nets etc.

LUGGAGE COMPARTMENT COVER



Luggage cover is designed only for hiding the luggage compartment.

iNOTE

Do not place anything on luggage cover or parcel shelf as it could obstruct driver's rear view. Also in case of an accident or sudden braking, it may cause an injury to the occupants.

FRUNK (if equipped)

Frunk is an extra storage provided in your vehicle under bonnet. . Load up to 6 kg is permissible.

Opening the Frunk

1. Open the bonnet and lock with stay rod.

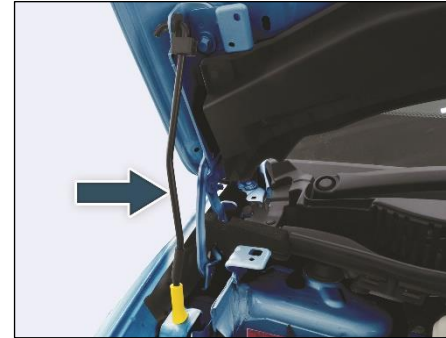

iNOTE

Before opening the frunk, please ensure that the bonnet is fully open and locked with stay bar.

STOWAGE AREA

2. Press the opening knob provided on frunk cover.



3. Open it fully and it shall remain open.



Closing the Frunk

1. Before closing the frunk cover ensure that there are no obstructions to it.
2. Push down the frunk cover and gently press it until it latches against the frunk latch.



CAUTION

- Do not overload the frunk, it may get damaged.
- Do not store fragile objects in the frunk.
- Do not store water/any liquid in the frunk, vehicle driving system may get damaged.

CAUTION

- Always ensure to keep the frunk cover closed while driving as stored items might come out of frunk/ may get damaged.
- Do not force press the frunk cover or place heavy objects on it, it may get damaged.

WARNING

- Never place/keep animals, baby, toddlers etc inside/outside the frunk, it can cause serious injury.
- Never try to enter inside frunk, it can cause serious injury.
- Do not store flammable/explosive items in frunk as it may catch fire if vehicle is exposed to high temperatures for long duration.

EMERGENCY EQUIPMENT

You should be familiar with the location of the emergency equipment provided in the vehicle and how to use it.

Do a check of this equipment periodically and make sure that they are in proper working condition and stowed at their locations.

First Aid Kit

The first aid kit is kept inside the glove box compartment.

The kit contains items that can be used in case of minor injuries only.

NOTE

Examine contents of the first aid kit periodically and replenish consumed or expired items.

Tool Kit

Following parts are provided in the Tool kit box in Luggage Compartment.



- Wheel Spanner
- Jack (if equipped)
- Tow hook
- Jack Handle (if equipped)
- Wheel cap removal tool (if equipped)

Advance Warning Triangle

An advance warning triangle is kept in the luggage compartment. Use advance warning triangle to warn the approaching traffic in case of vehicle break-down or during emergency, where your vehicle could become a potential traffic hazard.



When you press the hazard warning switch, all turn signal lamps will start to blink. Keep the warning triangle at an approximate distance of 50-150 m behind your vehicle in the same lane of traffic. The reflecting side of the triangle should face the oncoming traffic and it should be

EMERGENCY AND BREAKDOWN

free from any obstacles. Remove the advance warning triangle carefully from the bag and assemble. Refer instructions given on the bag.

NOTE

After using the warning triangle tie it firmly and keep it inside the bag to avoid rattling noise.

SPARE WHEEL REMOVAL PROCEDURE

- To access the spare wheel, lift the carpet up.
- After lifting, hold the carpet to access the spare wheel. Remove the Toolkit bag.



- To remove the spare wheel, unscrew and remove the retaining bolt.



WARNING

- “80 km/h” is the maximum speed you are permitted to drive with this tyre.
- Do not accelerate quickly, brake suddenly or drive at high speed through bends.
- After fitting the temporary spare wheel, the tyre pressure must be checked as soon as possible.
- Recommended tyre pressure is 35 psi (2.41 bar) for temporary spare wheel.

- Snow chains cannot be used on the temporary spare wheel.
- Never use more than one temporary spare wheel.
- Never use a temporary spare tyre if it is damaged or worn down to the tread wear indicators.
- The ground clearance of your vehicle may be reduced.
- The temporary spare should not be installed on the front axle if the vehicle must be driven in snow or once.
- Do not tow whilst the temporary spare wheel is installed.

NOTE

Your vehicle may exhibit some unusual driving characteristics when fitted with temporary spare wheel

IN CASE OF FLAT TYRE

- Reduce vehicle speed gradually, Avoid sudden steering movement or braking.
- Pay attention to the traffic conditions as you do so.
- Switch on the hazard warning lamps.
- Stop the vehicle on solid, non-slippery and level ground, as far away as possible from traffic.
- Use the Jack on level, hard ground. Avoid changing the wheel on uphill and downhill slopes. Chocks the wheels, if the deflated wheel needs to be changed on slope / ghat area.
- If possible, bring the front wheels into the straight-ahead position.
- Secure the vehicle against rolling away.
- Set the parking brake firmly and shifter in to "P" (Park) mode.
- Switch OFF the IGN.
- Keep advance warning triangle at a

suitable distance behind the vehicle as an indication of breakdown. Close all the doors.

WARNING

If you drive with a flat tyre, there is a risk of the following hazards:

- A flat tyre affects the ability to steer or brake the vehicle.
- You could lose control of the vehicle.
- Continued driving with a flat tyre will permanently damage the tyre and cause excessive heat build-up and possibly a fire. There is a risk of an accident.

EMERGENCY AND BREAKDOWN

Jack Up Point Location on Vehicle

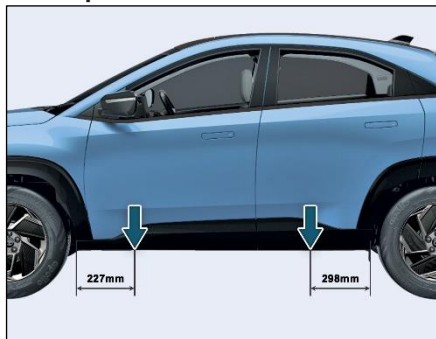

Jack point and location on vehicle

The jacking points  are indicated on sill cover of the vehicle (Refer jacking point location).

NOTE

The above image is only for reference.

WARNING

If you do not position the jack correctly at the appropriate jacking point of the vehicle, the jack could tip over with the vehicle raised. There is a risk of injury. Also jack can be damaged.

Changing Flat Tyre

Option I

Loosen the nuts (as indicated) on the wheel in diagonal sequence. Do not unscrew the nuts completely before raising the vehicle using the jack.



For Option II

To remove center cap, take out the remover tool from tool kit. Insert the tool in center cap hole & pull out the cap. Refer below fig.



Loosen the nuts (as indicated) on the wheel in diagonal sequence. Do not unscrew the nuts completely before raising the vehicle using the jack. Refer below fig.



Wheel Nut Removal

iNOTE

- The jack is designed only to raise and hold the vehicle for a short time while a wheel is being changed. It is not suited for performing maintenance work under the vehicle.
- Use the jack on level, hard ground. Avoid changing the wheel on uphill and downhill slopes. Chock the wheels, if the deflated wheel needs to be changed on slope / ghat area.

- Before raising the vehicle, secure it from rolling away by applying the parking brake.
- Do not use wooden blocks or similar objects as a jack underlay.
- Do not place your hands and feet or lie under the raised vehicle when it is supported by a jack.
- Do not start the vehicle when the vehicle is supported by the jack and never allow passengers to remain in the vehicle.
- Do not open or close a door or the tailgate when the vehicle is raised.

Assemble the Jack handle and wheel spanner (as shown in fig.)

Position the jack vertically and raise it by turning the jack handle clockwise until the jack sits completely on the specified point and the base of the jack lies evenly on the ground.



EMERGENCY AND BREAKDOWN

Continue to raise the jack slowly and smoothly until the tyre clears the ground. Do not raise the vehicle more than necessary.

Remove wheel nuts with the help of wheel spanner and take out flat tyre.

*i*NOTE

Do not place wheel nuts in sand or on a dirty surface. Do not apply oil or grease on it.

Roll the spare wheel into position and align the holes in the wheel studs.

Tighten each nut by hand until the wheel is securely seated on the hub.

Lower the jack completely then tighten the wheel nuts diagonally in opposite sequence one by one using wheel spanner.

Restore all the tools and jack at their respective locations.

Place the flat tyre at spare wheel location.

*i*NOTE

- *Do a check and correct the tyre pressure and wheel nuts tightness of the changed wheel at nearest*
- *TATA MOTORS EV Authorised service Centre. Get the flat tyre repaired at the earliest*
- *Do not jack the vehicle under rear axle.*

TOWING

Ensure EPB (if equipped) is not engaged as it can damage Brake pads and Brake components during vehicle towing.

1. EPB should be manually released if battery of the vehicle is healthy during towing and Ignition should be kept in ON state till vehicle reaches to TATA MOTORS EV Authorised Service Centre.
2. If vehicle battery is not in healthy state during vehicle towing external power is required for manual release of EPB and ignition should be ON till vehicle reaches to TATA MOTORS EV Authorised Service Centre.
3. If it is not possible to keep the ignition ON till vehicle reaches to service centre then keep EPB button pressed in release position, Brake paddle pressed and turn OFF the ignition this will avoid auto engagement of EPB during switching OFF the ignition.

NOTE

It is not recommended to touch/re move any component of Rear calipers to disengage the EPB as it will damage the caliper components permanently.

WARNING

DO NOT jump start the vehicle, since it is an EV. If the 12V battery is completely discharged, contact the nearest TATA MOTORS EV Authorised Service Centre.

Guidelines (Do's & Don'ts)

When towing a break down vehicle, certain precautions and procedures must be taken to prevent damage to the vehicle and/or components. Failure to use standard towing precautionary measures when lifting or towing a break down vehicle could result in an unsafe operating condition.

To correctly tow and prevent accidental damage to your vehicle, take help of a

TATA MOTORS EV Authorised Service Centre or a commercial tow-truck service.

NOTE

Make sure that the parking brake is released; vehicle is in neutral and steering wheel is unlocked. The power steering functions only when vehicle is running. Hence, during towing the steering efforts will be more.

WARNING

- Do not get under your vehicle after it has been lifted by a tow truck.
- For towing a vehicle, the best way is to use a wrecker. Alternatively use a rigid tow bar.
- Switch 'ON' the hazard warning indicators of both the vehicles to warn other road users.
- Limit the speed to 20-30 kmph.
- In case of brake failure, use the parking brake to control the vehicle.
- Fasten the tow rope or tow bar at

EMERGENCY AND BREAKDOWN

the towing eyes. Otherwise, the vehicle could be damaged.

- When towing, pull away slowly and smoothly. If the tractive power is too high, the vehicles could be damaged.

Tow Hook Fitment

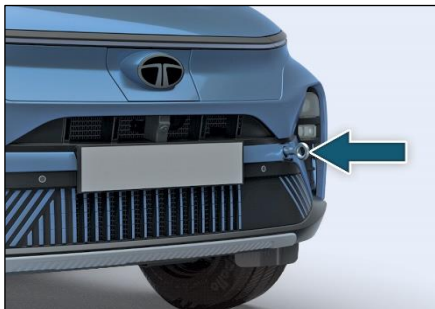

- Open the tailgate and remove tow hook from the tool kit.
- Open the tow hook cover provided on the front bumper by pressing it at the bottom part and simultaneously pulling it at the top (as shown in fig).
- Screw in and tighten the tow hook in clockwise direction.
- After towing, remove the towing hook and press fit the cover properly.
- Place the towing hook in the vehicle tool kit.

Recommended Towing

In case of break down, we recommend that your vehicle be towed with the driving wheels off the ground or place the vehicle on a flatbed truck as shown.

WARNING

- Do not tow your vehicle with the front wheels on the ground or four wheels on the ground (forward or backward), as this may cause serious damage to the transmission.
- When towing with the rear wheels on the ground or on towing dollies, place the ignition switch in the 'ACC' or 'ON' position, and secure the steering wheel in the straight-ahead position with a rope or similar device.

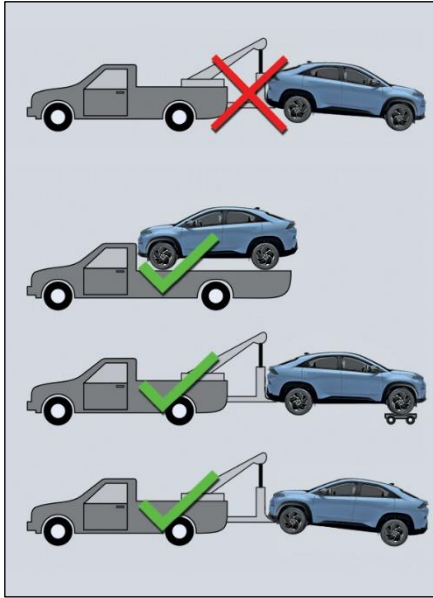

FUSES

Your vehicle has fuse boxes at three locations.

The vehicle's electrical circuits have fuses to protect the wiring from short circuits or sustained overload.

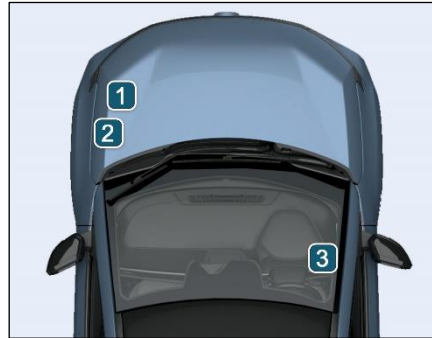

1. Battery Mounted Fuse Box.
2. Motor Compartment Fuse Box.
3. Cabin Compartment Fuse Box.

Checking and Replacing Fuses

If any electrical unit in your vehicle is not functioning, check the fuses first.

Please follow the steps below that will guide you to check and replace them.

- Apply parking brake
- Switch off all electrical accessories.
- Turn the ignition key to the 'LOCK' position.
- In the fuse box, identify the defective fuse from its melted wire.

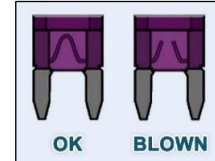

- Remove the defective fuse by "fuse puller". The fuse puller and spare fuses are provided in the motor compartment fuse box.
- Defective fuses must be replaced with fuses of same rating, which you can recognize by color and value. Fuses

EMERGENCY AND BREAKDOWN

of same rating, which you can recognize by color and value.

NOTE

Always make sure that the spare fuses are added.

- Make sure that all other fuses are pressed firmly in position.
- If a newly inserted fuse also blows, have the cause traced and rectified at nearest TATA MOTORS EV Authorised Service Centre immediately.

WARNING

- If you manipulate or bridge a faulty fuse or if you replace it with a fuse with higher amperage, the electric cables could be overloaded. This could result in a fire. There is a risk of an accident and injury.
- Always replace faulty fuses with the specified new fuses having the correct amperage.

Battery Mounted Fuse Box

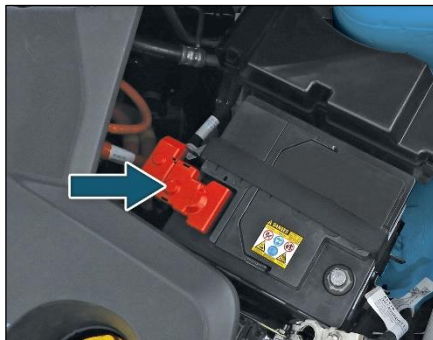

WARNING

If fuse box cover is removed for any reason, it should be refitted properly in its original position.

Motor Compartment Fuse Box

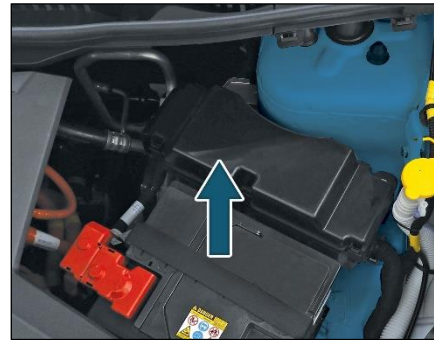

NOTE

The fuse box layout is for reference purpose only. Please refer the sticker provided inside the fuse box cover.

EMERGENCY AND BREAKDOWN

Under Bonnet Fuse Details			
Fuse No.	Ratings (Amp)	Fuse Type	Description
EF0	-	-	SPARE
EF1	60A	JCASE	INTERIOR F/B - 2 IGNITION
EF2	60A	-	INTERIOR F/B - 2 BATTERY
EF3	60A	JCASE	IVBAC MOTOR
EF4	40A	JCASE	COOLING FAN FAST
EF5	40A	JCASE	EV POWER TRAIN
FE6	25A	JCASE	COOLING FAN FAST
EF7	60A	JCASE	INTERIOR F/B-1 BATTERY
EF8	30A	JCASE	MAIN RELAY
EF9	60A	JCASE	IVBAC MOTOR
EF10	40A	JCASE	IGN LOADS
EF11	60A	JCASE	MANDO EPAS
EF12	5A	MINI	VCU KP SUPPLY BATT
EF13	-	-	SPARE
EF14	10A	MINI	AVAS
EF15	5A	MINI	CENTRAL LAMP
EF16	15A	MINI	HORN
EF17	5A	MINI	ELECTRIC CHARGE LID OPENER
EF18	5A	MINI	MONO STABLE SHIFTER MR/LR
EF19	-	-	SPARE

EMERGENCY AND BREAKDOWN

Under Bonnet Fuse Details			
Fuse No.	Ratings (Amp)	Fuse Type	Description
EF20	10A	MINI	BMS POWER_BATT
EF21	5A	MINI	BRAKE SW
EF22	5A	MINI	CHILLER SOLENOID
EF23	5A	MINI	E DRIVE BATT RELAY CONTROL
EF24	5A	MINI	EVAPORATOR SOLENOID
EF25	10A	MINI	REVESE LAMP
EF26	5A	MINI	E DRIVE BATT
EF27	10A	MINI	OBD BATT
EF28	10A	MINI	HV BATTERY COOLING PUMP BATT
EF29	10A	MINI	TRACTION COOLANT PUMP BATT
EF38	30A	MINI	VCU
EF39	5A	MINI	PT RELAY CONTROL
EF40	10A	MINI	3 IN COMBO
EF41	5A	MINI	COMPRESSOR BATT
EF42	5A	MINI	IVBAC
EF43	20A	MINI	FRONT WIPER MOTOR
EF44	5A	MINI	IGN SUPPLY 3
EF45	-	-	SPARE

EMERGENCY AND BREAKDOWN

Relay No.	Fuse Rating	Function
R1	-	SPARE
R2	-	SPARE
R3	20A	HV BATTERY KP ALIVE RELAY
R4	40A	VCU MAIN RELAY
R5	20A	COOLING FAN SLOW
R6	40A	COOLING FAN FAST 1
R7	20A	INT WIPE (ON/OFF)
R8	20A	COOLANT PUMP BATT
R9	-	SPARE
R10	40A	COOLING FAN FAST 2
R11	-	SPARE
R12	20A	E DRIVE BATT SUPPLY RELAY
R13	-	SPARE
R14	-	SPARE
R15	20A	SPARE
R16	20A	HORN
R17	40A	IGNITION
R18	20A	FRONT WIPER MOTOR SPEED
R19	20A	REVERSE LAMP RELAY

Under Bonnet Low Voltage Service Disconnect

During the service of vehicle, the technician or service operator can be prone to electric shock with High Voltage.

So to avoid this electric shock hazard the high voltage should be disconnected before servicing the vehicle.

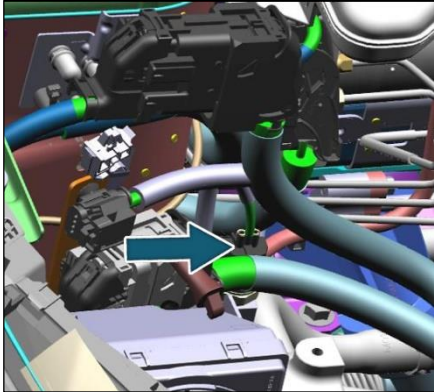

Below steps to be followed to isolate High voltage from vehicle and components:-

- Technician or service operator should locate the motor compartment which is located under the bonnet.
- Without touching any other high voltage components he should remove the LV MSD short link connector.
- LV MSD connector is connected with green color connector parked near to RH Suspension Tower over a bracket.
- LV MSD short link connector labeled with yellow color (As per picture).

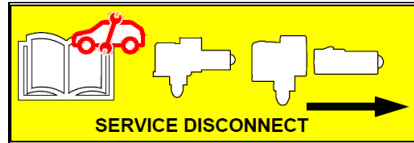

- After successfully completion of service LV MSD short link must be re-connected with green link connector same as original condition.

Under Bonnet High Voltage Service Disconnect

During the service of vehicle, the technician or service operator can be prone to electric shock with Low Voltage.

So to avoid this electric shock hazard the high voltage should be disconnected before servicing the vehicle.

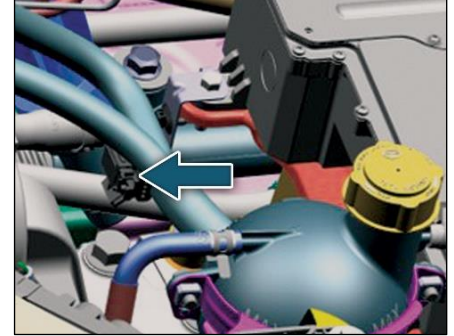

EMERGENCY AND BREAKDOWN

Below steps to be followed to isolate High voltage from vehicle and components:-

- Technician or service operator should locate the motor compartment which is located under the bonnet.
- Without touching any other high voltage components he should remove the HV MSD short link connector.
- HV MSD connector is connected with green color connector parked near to 3in1 combo unit over a bracket .
- HV MSD short link connector labeled with yellow color (As per picture).



- After successfully completion of service HV MSD short link must be re-connected with green connector same as original condition.

Accident Disconnect Fuse

In case of an accident, to disconnect the high voltage battery from the rest of the high voltage electrical components, remove the cover of the fuse and pull out the accident disconnect fuse. The fuse can be identified with a yellow label.

WARNING

In case of Accident/Emergency/ Crash, the rescuer or first emergency responder may be prone to Electric Hazard.

To avoid the Electric hazard, the Power supply to Battery Management System must be disconnected.

Follow the steps below to disconnect the power supply from the battery management system:

- Open the fuse box cover located under the bonnet behind the 12V battery without touching any other High Voltage Components.



Remove the Accident Disconnect 10A fuse. The fuse puller and spare fuses are provided in the motor compartment fuse box

The 10A fuse labelled in yellow color as shown in image.

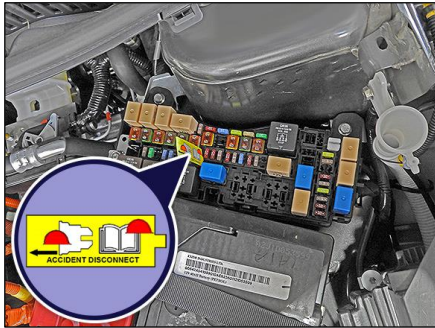

WARNING

If Fuse box cover is removed for any reason, it should be refitted properly at its original position.

NOTE

The fuse box layout is for reference purpose only. Please refer the sticker provided inside the fuse box cover.

Cabin Compartment Fuse Box

Cover Removal Procedure

Fuse box is located inside the cover below steering column. To access the fuse box, remove cover as per procedure given below.

1. Fuse box cover is mounted on dash board with the help of lugs at the top and bottom of the cover from inside.

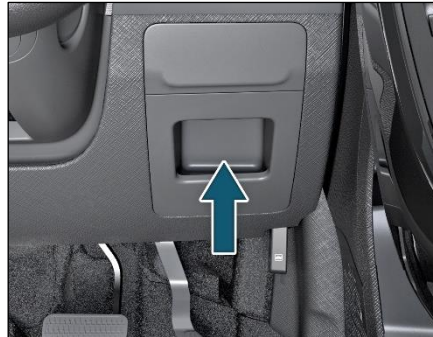

2. To remove the cover, gently pull the cover from upper side that the lugs get disengaged.

Re-fitment Procedure

Align bottom lugs and push upper part with respective slots on dash board and press the cover firmly.

EMERGENCY AND BREAKDOWN

Fuses - Cabin Compartment

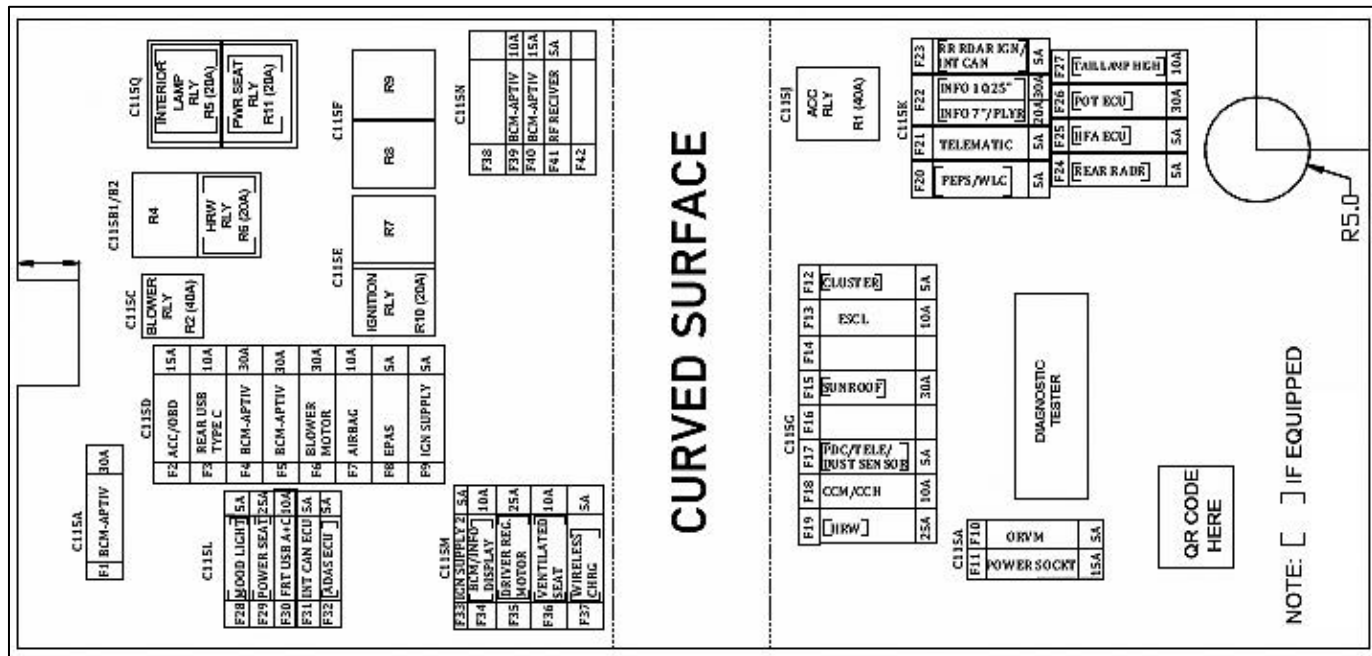

Note: Please refer fuse box sticker on vehicle for more clarity.

EMERGENCY AND BREAKDOWN

Cabin Compartment Fuse Box Details

Fuse No	Ratings (Amp)	Fuse Type	Description
F1 (C115A)	30A	MINI	BCM APTIV
F2 (C115D)	15A	MINI	ACCESSORY/OBD BATT
F3 (C115D)	10A	MINI	POWER SOCKET 2
F4 (C115D)	30A	MINI	BCM_APTIV
F5 (C115D)	30A	MINI	BCM_APTIV
F6 (C115D)	30A	MINI	BLOWER MOTOR
F7 (C115D)	10A	MINI	AIRBAG
F8 (C115D)	5A	MINI	EPAS
F9 (C115D)	5A	MINI	IGN SUPPLY
F10 (C115A)	5A	MINI	MIRROR ADJUST MOTORS
F11 (C115A)	15A	MINI	POWER SOCKET 1
F12 (C115G)	5A	MINI	CLUSTER
F13 (C115G)	10A	MINI	ESCL
F14 (C115G)	5A	MINI	ILLUMINATION
F15 (C115G)	30A	MINI	SUNROOF
F16	-	MINI	SPARE

EMERGENCY AND BREAKDOWN

Cabin Compartment Fuse Box Details			
Fuse No	Ratings (Amp)	Fuse Type	Description
F17 (C115G)	5A	MINI	WIRELESS CHARGER
F18 (C115G)	10A	MINI	CCM/CCH
F19 (C115G)	25A	MINI	HEATED REAR SCREEN
F20 (C115K)	5A	MINI	PEPS/WLC
F21 (C115K)	25A	MINI	DRIVER REG MOTOR
F22 (C115K)	20A	MINI	INFOTAINMENT CONTROL MODULE 7
F22_A (C115K)	30A	MINI	INFOTAINMENT CONTROL MODULE 10.25
F23 (C115K)	5A	MINI	BCM/INFO DISPLAY
F24 (C115K)	5A	MINI	HFA ECU
F25 (C115K)	5A	MINI	REAR RADAR LH/RH
F26 (C115K)	30A	MINI	POT ECU
F27 (C115K)	10A	MINI	Tailgate Lamp HIGH
F28 (C115L)	5A	MINI	MOOD LIGHT FUSE
F29 (C115L)	25A	MINI	POWER SEAT
F30 (C115L)	10A	MINI	Front USB Charger (A+C)

Cabin Compartment Fuse Box Details			
Fuse No	Ratings (Amp)	Fuse Type	Description
F31 (C115L)	5A	MINI	INTERCAN ECU
F32 (C115L)	5A	MINI	TELEMATIC
F33 (C115L)	5A	MINI	REAR RADAR IGN/INT CAN
F34 (C115M)	5A	MINI	ADAS_FR RADAR/CAMERA
F35 (C115M)	10A	MINI	VENTILATED SEAT
F36 (C115M)	5A	MINI	IGN SUPPLY 2
F37 (C115M)	5A	MINI	PDC/ TELEMATIC/DUST SENSOR
F38	-	MINI	SPARE
F39 (C115N)	10A	MINI	(BCM04)
F40 (C115N)	15A	MINI	(BCM04)
F41 (C115N)	5A		(BCM04 && PEP01)

EMERGENCY AND BREAKDOWN

Cabin Compartment Fuse Box Relay Details			
Relay No	Ratings (Amp)	Relay Type	Load Passed
R1 (C115-J)	40A	MINI RELAY N/O	ACC RELAY
R2 (C115-C)	40A	MINI RELAY N/O	WW. SIGNAL INV. RLY
R3	-	MINI	SPARE
R4	-	MINI	SPARE
R5 (RC115Q)	20A	MICRO N/C	INTERIOR LAMP RELAY
R6 (C115B2)	20A	MICRO N/O	HEATED REAR WINDOW
R7	-	MICRO C/O	SPARE
R8	-	MICRO C/O	SPARE
R9 (C115E)	20A	MICRO N/O	ILLUMINATION
R10 (C115E)	20A	MICRO N/O	IGNITION RELAY
R11 (C115Q)	20A	MICRO N/O	POWER SEAT RELAY
R12	MICRO	-	SPARE
R13	MICRO N/O	-	SPARE

EMERGENCY AND BREAKDOWN

Cabin Compartment Fuse Box Relay Details			
Relay No	Ratings (Amp)	Relay Type	Load Passed
R14	MICRO	-	SPARE
R15	MICRO	-	SPARE
R16	MICRO	-	SPARE
R17	MICRO	-	SPARE

EMERGENCY AND BREAKDOWN

If An Accident Occurs...

- If your vehicle is drivable, park your vehicle off the road; rotate the shifter to "N" and apply the parking brake.
- If not drivable do not try to start the vehicle. Rotate the shifter to N and apply the parking brake.
- Roll down the windows and open the door locks if possible. If the 'Ready' message does not come in the instrument cluster, do not try to switch ON the supply by pressing the Start/Stop button.
- If there is no electrical supply, at-least try to unlock single door manually.
- If the vehicle 'Ready' message flashes in the instrument cluster, press the Start/Stop button to turn off the supply, and ensure 'Ready' message goes off to verify the high-voltage system is disconnected.
- De-latch the bonnet from inside the cabin by pulling the lever to open it.
- If the lever is not reachable, do not spend time to de-latch the bonnet.

- Come out of the vehicle and move the smart key at least 2 meters away from the vehicle to avoid any accidental restart or activation of high voltage systems.
- Try to evacuate the occupants from inside of the vehicle.
- Secure vehicle by barricading it, without touching the vehicle.
- Inform the TATA MOTORS Roadside Assistance immediately.
- Do not touch the vehicle. Keep a safe distance.

WARNING

- Do not touch electric wires that maybe come exposed from inside or outside the vehicle, high voltage electric wires (orange), connectors and any exposed electric components and devices. Doing so may result in electric shock and lead to injuries or even death.
- If you observe any coolant leaks and rupture in refrigerant lines, do not drive the vehicle and contact

TATA MOTORS Roadside Assistance.

- If the vehicle switches off after an accident, come out of the vehicle immediately without touching any metal parts.
- Leaks or damage to the Li-ion battery may result in a fire. If you discover them, contact emergency services immediately. Never touch the fluid leaked inside or outside the vehicle. If the fluid contacts with your skin or eyes, wash it off immediately with a large amount of water or saline solution and receive immediate medical attention to help avoid serious injury.
- If water enters inside the vehicle: If your vehicle is flooded or if water has soaked the carpets, you should not try to start the vehicle. Never touch the high voltage cables, connectors and package modules, because an electric shock may occur causing injury or death. (High voltage components are orange in colour)

- If a submersion in water occurs: Do not touch your vehicle, if the vehicle has been submerged in water. The high voltage battery may cause shock or may catch fire. Immediately contact the authorities and advise them of the condition of your vehicle and that an electric vehicle is involved.

If a small scale fire occurs, use a fire extinguisher (C, ABC, BC) that is meant for electrical fires. If it is impossible to extinguish the fire in the early stage, remain a safe distance from the vehicle and immediately call the authorities. Also, advise them that an electric vehicle is involved.

When approaching a high voltage vehicle in a situation of fire, rescue or recovery, follow the standard rule:

- Always assume the high-voltage system is live in the vehicle.
- Only High Voltage System trained personnel with necessary high voltage PPEs (hand gloves, electrical safety shoes, etc.,) should access and an a

lyse the EV after all occupants are safely evacuated.

- As EV service requires certain skill-sets and trained manpower, it is always recommended to get the car serviced or repaired at only TML authorized EV workshop.

Emergency Shut OFF System

When vehicle detects any fault in HV system, it activates the emergency shut OFF for safety purpose. Even if the shifter is in Drive mode, the system may shut-OFF suddenly. In this case, contact the nearest TATA MOTORS EV Authorised Service Centre to rectify the issue.

In Case of Emergency

If the vehicle stalls at a crossroad or crossing, shifter shift to N (Neutral) position and then push the vehicle to a safe place.

If the Vehicle Stalls While Driving

- Reduce your speed gradually, keeping a straight line. Move cautiously off the road to a safe place.

- Turn on the hazard lamps.
- Try to start the vehicle again. If your vehicle does not start, contact TATA MOTORS EV Authorised Service Centre.
- Since this vehicle runs on electric power, it generates little sound. Beware of your driving environment and drive safely.
- After you park the vehicle or while you are waiting at a traffic light, check whether there are kids or obstacles around the vehicle.
- Check if there is something behind the vehicle when driving in reverse. Pedestrians may not hear the sound of the vehicle.

EMERGENCY AND BREAKDOWN

BULB SPECIFICATION

S.N.	Description	Rating	Type	Qty.
1	REAR BOOT LAMP	12V,5W	W5W	1
2	GLOVE BOX LAMP	12V, 5W	W5W	1
3	REVERSE LAMP	12V,21W	W21W	2

24 X 7 ROADSIDE ASSISTANCE

Dear Customer,

It is our responsibility and our endeavor to ensure that you have our complete service backup if ever, wherever and whenever you need the same. When you have a road network that spans wide area, the probability of a breakdown happening within hailing distance of a TATA MOTORS EV Authorised Service Centre is very low.

It is precisely for this reason, we have tied up with TVS Auto Assist, who will provide breakdown assistance including towing to the nearest TATA MOTORS EV Authorised Service Centre through their Authorized Service Providers (ASP).

The 24X7 On Roadside Assistance Program shall be automatically available to your vehicle for the duration of Warranty period. The program shall also be available, if you avail the same post warranty.

Standard Procedure When Calling For Roadside Assistance In Case Of a Breakdown

- Dial the toll free help line number – 1800 209 8282
- Identify your vehicle with the Vehicle chassis number that is available in the Owner's Manual.
- Explain your exact location with landmarks and tell us about the problem you face with the vehicle.
- Park your vehicle on the edge of the road, open the bonnet and put on the hazard warning signal.
- Place the advance warning triangle supplied with the vehicle approx. 3 m from the vehicle in the direction of on-coming traffic.

Coverage under 24 X 7 Roadside Assistance Program

- I. The **24x7 Roadside Assistance** Program Service covers the following services on your vehicle during warranty period.

- Wheel change through spare wheel (if equipped)
- Re-opening the vehicle in cases of key lock out.
- Rectification of electrical problems related to battery, fuses etc.
- On spot repairs for complaints repairable at site. ^
- Vehicle to vehicle towing or winching & towing for non-accident cases up to the nearest TATA MOTORS EV Authorized Dealer/Service Center. Towing charges at actual cost beyond the same to be paid to the ASP in cash/online. (Any ferry or toll charges levied in relation to the vehicle being towed to be paid by the customers in actuals in cash/online).
- In the event of major accident ambulance assistance will be provided if needed (If equipped).

EMERGENCY AND BREAKDOWN



- II. The **24x7 Roadside Assistance** Program coverage on availing the 24X7 policy, post warranty is upto maximum of 6 instance of assistance in one year for both the plans- Basic and Premium. In the premium plan, this includes 2 instances of towing up to the nearest TATA MOTORS EV Authorised Service Centre.

Exclusions

24 X 7 Roadside Assistance Program does not apply to

- Cost of parts consumables and labor for such repairs not covered under warranty*. These charges are to be settled with ASP in cash/online.

- Toll or ferry charges paid by ASP in reaching to the breakdown site to be settled with ASP in actuals in cash/online.
 - Cases involving accident, fire, theft, vandalism, riots, lightening, earthquake, windstorm, hail, tsunami, unusual weather conditions, other acts of God, flood, etc.
 - Vehicles that are unattended, un-registered, impounded or abandoned.
 - Breakdown/defects caused by misuse, abuse, negligence, alterations or modifications made to the vehicle.
 - Lack of maintenance as per the Maintenance schedule as detailed in the owner's manual.
 - Cases involving racing, rallies, vehicle testing or practice for such events.
- Disclaimer**
- The Service is not available in Lakshadweep. **The reach time is indicative & the actual reach time will be conveyed by the call center at the time of breakdown call.
 - The reach time can vary depending on the traffic density & time of the day.
- The reach time indicated does not account for delays due to but not limited to acts of God, laws, rules & regulations for time being in force, orders of statutory or Govt. authorities, industrial disputes, inclement weather, heavy down pour, floods, storms, natural calamities, road blocks due to accidents, general strife and law & order conditions viz. fire, arson, riots, strikes, terrorist attacks, war etc.
 - ^ On spot repairs at breakdown site shall depend on nature of complaints & will be as per the discretion of the ASP.
 - * The decision for free of charge repairs will be as per the warranty policy & procedures of TATA PASSENGER ELECTRIC MOBILITY LTD. and as per the interpretation of the same by ASP. You will be duly informed by the ASP & call center for the change applicable if any.
 - All charges wherever applicable need to be settled directly with the ASP.

Exclusion of Liabilities

- It is understood that TATA MOTORS shall be under no liability what so ever in respect of any loss or damage arising directly or indirectly out of any delay in or non-delivery of, defect/deficiency in service/parts provided by ASP.
- In case vehicle cannot be repaired on-site, customers are advised to use the towing facility for taking their vehicle to the nearest TATA MOTORS EV Authorised Service Centre only. In no condition shall the vehicle be towed to any TATA MOTORS EV Authorised Service Centre. TATA MOTORS will not be responsible for any repairs carried out in such unauthorized workshop.
- Customer are advised to take acknowledgment from the ASP for the list of accessories/extra fittings and other belongings in the vehicle as well as the current condition related to dents/scratches breakages of parts/fitments of the vehicle at the

time of ASP taking possession of the vehicle & to verify these items when delivery is taken back by them, Claim for loss of or damage to items, if any should be taken up with ASP directly. TATA MOTORS shall not be responsible for any such claims, damages/loss or any deficiency of service of the ASP.

- Vehicles will be handled, repaired & towed as per the customer's risk & TATA MOTORS shall not be liable for any damages / claims as a result of the same.
- Services entitled to the customers can be refused or cancelled on account of abusive behavior, fraudulent representation, malicious intent and refusal to pay the charges for any charges related services and spare parts during service or on previous occasions on part of the customer.
- On site repairs may be temporary in nature. The completion of repairs does not certify the road worthiness of the vehicle. The customer is advised

to ensure temporary repairs carried out onsite is followed by permanent repair sat a TATA MOTORS EV Authorised Service Centre at the earliest. Terms and conditions and service coverage, exclusions etc. are subject to change without notice.

E-call and B-call Services

1. Emergency hard switch button is present on roof console to operate the E-Call / B-Call feature (Emergency Medical Assistance / Breakdown Assistance)
2. Emergency call gets triggered when user presses the hard switch button, if by chance call gets disconnected then user will get call back from Allianz agent within 3 mins. During this 3 minutes time duration user can not trigger another E-Call and green lights will remain ON.
3. Also, in case of vehicle crash, E-Call automatically triggers.
4. On pressing emergency call button, a popup message appears on HU stating: "Dialing emergency number in 5 seconds" & have a cancel button on

EMERGENCY AND BREAKDOWN

the message box, so that user can cancel connecting to emergency number in case it was done unknowingly.

5. In case of breakdown B-Call can be triggered by pressing B-Call switch. In B-Call, no call back scenario is present. User has to again re-initiate the B-Call feature via hard switch or soft switch.
6. Once call is connected, user can cancel the call using hard press button.

NOTE

**Subject to mobile network, connectivity and location mentioned.*

Response Time ** For The E-call (roadside Assistance Program)	
Reach time within city (Listed 54 cities)	45 Minutes
Reach time On State and National High- ways	90 Minutes
Reach time on remote location	120 Minutes +/-

Response Time ** For The B-call (roadside Assistance Program)	
Within City Limits	60 minutes
Highways and other places	120 minutes +/-
States of North East, J&K and Himachal	Same Day (Within 24 Hrs.)
** The response time will depend on the location, terrain, traffic density and the time of the day.	

E-call And B-call LED Indications

Sr. No	Parameters	System Health Led- Red	Call Status Led- Green
1	During IGN ON	LED remains ON for 3 Sec	LED remains ON for 3 Sec
2	Subscription Active	OFF	OFF
3	Subscription Expired	Slow Blinking (0.5 Sec ON & 4 Sec OFF)	OFF
4	During Call Initiation	OFF	Fast Blinking (0.5 Sec ON & 0.5 Sec OFF)
5	Call Connected	OFF	Permanent ON
6	System Failure	ON	OFF

List of below cities coverage for E-Call support

Ambulance services will be provided only in the cities mentioned under the below mentioned categories. Allianz shall provide an ambulance with basic life support or advanced life support based on the availability at the time of emergency call received from the breakdown location. The criteria to choose the kind of ambulance shall be as per the requirement of the customer, distance from the breakdown location & the nearest hospital & subject to availability. The judgement of Allianz in all cases will be final.

EMERGENCY AND BREAKDOWN

Category A:

Ambulance services will be given under municipal limits of these cities varying from 15-25 Km radius.

Hyderabad	Vadodara	Coimbatore	Madurai	Noida
Bangalore	Kochi	Vijayawada	Kolhapur	Jaipur
Mumbai	Trivandrum	Vizag	Mysore	Jodhpur
Kolkata	Indore	Raipur	Aurangabad	Chandigarh
Chennai	Nagpur	Surat	Kozikhode	Patna
Delhi	Pune	Rajkot	Warangal	Amritsar
Gurgaon	Bhubaneshwar	Bhopal	Cuttack	Navi Mumbai
Faridabad	Lucknow	Ranchi	Goa	Thane
Ghaziabad	Kanpur	Nashik	Pondicherry	
Ahmedabad	Varanasi	Mangalore	Guntur	

Category B:

Ambulance services will be given under municipal limits of these within 15 Km radius.

Adilabad	Dahod	Khandwa	Rajnandgaon
Adityapur	Dakshin Dinajpur	Kharagpur	Ramanathapuram
Agartala	Daman	Kishanjang	Rampur
Agra	Dankuni	Koch Bihar	Raniganj
Ahmednagar	Darbhanga	Kollam	Ratlam
Aizawl	Darjeeling	Korba	Rewa

EMERGENCY AND BREAKDOWN

Ajmer	Davanagere	Kota	Rewari
Akola	Dehradun	Kottayam	Rishikesh
Alappuzha	Deoghar	Kovilpatti	Rohtak
Aligarh	Deoria	Kozhikode	Roorkee
Allahabad	Dhanbad	Krishnagiri	Rourkela
Ambala	Dhar	Kurnool	Rudrapur
Ambikapur	Dharamshala	Kurukshetra	Sagar
Ambur	Dharbhanga	Kutch	Saharsa
Amethi	Dharmapuri	Lakhimpur Kheri	Salem
Amravati	Dharmavaram	Lalitpur	Samastipur
Amreli	Dharwad	Latur	Sambalpur
Anand	Dhaulpur	Lonavala	Sangli
Anantapur	Dhule	Ludhiana	Sangrur
Ankleshwar	Dibrugarh	Maharajganj	Satara
Arakkonam	Dindigul	Mahbubnagar	Satna
Ariyalur	Dispur	Mahesana	Secunderabad
Arrah	Durg	Mainpuri	Sehore

EMERGENCY AND BREAKDOWN

Bagbera	Etawah	Mansa	Shimla
Baghpat	Faizabad	Mapusa	Shimoga
Bahadurgarh	Farrukhabad	Margao	Sholinghur
Bahraich	Fatehpur	Mathura	Sholingur
Balaghat	Ferozpur	Mau	Siddharthnagar
Balasore	Firozabad	Mavelikara	Sikar
Baleshwar	Firozpur	Medak	Siliguri
Ballia	Gadwal	Medinipur	Sirsa
Baloda	Gandhidham	Meerut	Sitapur
Balrampur	Gandhinagar	Mehsana	Sivaganga
Bambolim	Gaya	Miryalaguda	Siwan
Banda	Ghazipur	Mirzapur	Solan
Bankura	Giridih	Moga	Solapur
Barasat	Godhra	Moradabad	Sonbhadra
Bareilly	Gonda	Morbi	Sonipat
Barwani	Gondia	Morena	Sri City
Basti	Gorakhpur	Motihari	Sri Ganganagar
Bathinda	Gudivada	Muktsar	Srirangam
Begusarai	Gulbarga	Murshidabad	Sullurupeta
Belgaum	Guna	Muzaffarnagar	Supaul
Bellary	Gurdaspur	Muzaffarpur	Suryapet
Bengaluru	Guwahati	Nadia	Tadepalligudem

EMERGENCY AND BREAKDOWN

Betul	Gwalior	Nagapattinam	Tambaram
Bhadohi	Hajipur	Nagercoil	Taregana
Bhadrak	Haora	Nainital	Tatanagar
Bhagalpur	Hapur	Nalgonda	Tenkasi
Bharatpur	Hardoi	Namakkal	Thalassery
Bharuch	Haridwar	Nanded	Thanjavur
Bhatinda	Hassan	Nandyal	The Nilgiris
Bhavnagar	Hathras	Navsari	Theni
Bhilai	Hazaribagh	Nawanshahr	Thiruchirapalli
Bhilwara	Hingoli	Nellore	Thiruvalla
Bhind	Hisar	New Farakka	Thiruvallur
Bhiwani	Hooghly South	Nizamabad	Thiruvananthapuram
Bhuj	Hoshiarpur	North Twenty four Parganas	Thiruvarur
Bhusawal	Hosur	Ooty	Thrissur
Bidhan Nagar	Hubli	Osmanabad	Thrivandram
Biharsharif	Imphal	Palamapur	Tindivanam
Bijapur	Jabalpur	Palampur city	Tiruchirappalli
Bijnor	Jaisalmer	Palanpur	Tirunelveli

EMERGENCY AND BREAKDOWN

Bikaner	Jalandhar	Pali	Tirupati
Bilaspur	Jalgaon (Chalisgaon)	Panaji	Tirupattur
Birbhum	Jalgaon	Panipat	Tiruppur
Bokaro	Jalpaiguri	Panjim	Tirur
Bolpur	Jammu	Panna	Tiruvanamalai
Brahmapur	Jamnagar	Pantnagar	Toothukudi
Bulandshahr	Jamshedpur	Parappanangadi	Tumkuru
Buxar	Jaunpur	Paravur	Tundla
Calicut	Jehanabad	Parbhani	Udaipur
Chaibasa	Jhansi	Pathankot	Udupi
Chakradharpur	Jhunjhunu	Patiala	Ujjain
Chakulia	Jind	Perambalur	Unnao
Champa	Jorhat	Phagwara	Vaikom
Chandauli	Junagadh	Phaphund	Valsad
Chandil	Jyotiba Phule Nagar	Pithapuram	Vaniyambadi
Channapatna	Kaithal	Pollachi	Vapi
Chapra	Kancheepuram	Ponda	Varkala Sivagiri
Chengalpattu	Kanniyakumari	Port Blair	Vellore
Chhatarpur	Kannur	Prayagraj	Viluppuram

EMERGENCY AND BREAKDOWN

Chhindwara	Kanpur Nagar	Puducherry	Virudhampet
Chhota Gobindpur	Kanyakumari	Pudukkottai	Virudhunagar
Chitradurga	Karimnagar	Puri	Visakhapatnam
Chitrakoot	Karnal	Purna	Wardha
Chittoor	Katni	Purnia	Yavatmal
Churu	Katpadi	Rae Bareli	Yelahanka
Cooch Behar	Kaushambi	Raigar	Yemmiganur
Chhindwara	Kanpur Nagar	Puducherry	Virudhampet
Cuddalore	Kayamkulam	Raigarh	Yeswanthpur
Cuddapah	Khammam	Rajahmundry	

Category C:

For Outside city Limit cases & rest of the cities – Services will be aligned on best effort basis utilizing the service network from the nearest city or publicly available network.

AWP's liability for the provision of Assistance Services will cease once the emergency services have arrived at the breakdown location or on completion of towing or upon arrival of the Covered Vehicle at Authorized TATA MOTORS EV Dealer or TATA MOTORS EV Authorized Service Centre.

EMERGENCY AND BREAKDOWN

LUBRICANT SPECIFICATIONS

Use following genuine fluids, coolants and lubricants recommended for optimum performance of your vehicle.

Item	Specification	Company	Brand	Qty.
Coolant (Pre- mixed) (Anti-freeze agent +Soft water 40:60 ratio)	Class II/JIS K2234 TATA SS7700S1	SUNSTAR CCI	Golden Cruiser LLC 2200NP	BCS 4.7 L TCS 3.5 L
		IOCL	TATA MOTORS GENUINE COOLANT KOOL PLUS	
Transaxle Oil	Synthetic SAE 75W90 BOT130M	Castrol	Castrol	0.9 L
Brake Fluid	DOT 4	PETRONAS	PETRONAS TATA MOTORS Genuine Brake Oil DOT 4S	690 +/- 5% ml
		Sunstar CCI	Golden Cruiser TATA Genuine Brake Fluid (DOT4)	
		CASTROL	Optional - CASTROL-Universal Brake Fluid DOT 4	
Refrigerant	R-134a	-	-	560±20 gms
AC Compressor Oil	ZEROL ESTER 68 HYBRID oil	Shrive	ZERO ESTER 68HYBRIDE PVE FVC56EA / FVC68D	150+10 ml-0
Sunroof Grease	MULTEMP 2C194	—	—	As required

TECHNICAL SPECIFICATION

VEHICLE SPECIFICATIONS

Parameter	Curvv EV
Powertrain	
Battery	Option I - 45 kWh , Option II - 55 kWh Li-ion
Electric motor	Permanent magnet synchronous motor
Nominal voltage	Option I - 326.4 V , Option II -345.6 V
Maximum power, kW	Option I - 110 kW , Option II - 123kW
Maximum torque, Nm	215 Nm
Transaxle	
Model and Type	Electric Vehicle Transaxle
No. Of gears	Single speed, 1 Forward Drive + 1 Reverse Drive
Steering	
Type	Column Mounted Electric Power Assisted Steering System
Brakes	
Brakes	Front (Disc); Rear (Disc)
Parking brake	Automatic Parking Brake
Shock absorber	
Front and Rear	Double acting telescopic type; Hydraulic gas filled

TECHNICAL SPECIFICATION

Parameter	Curvv EV
Suspension	
Front	Independent, lower wishbone , Mcpherson strut with coil spring & anti roll bar
Rear	Semi-Independent twist beam with coil spring and shock absorber
Wheels & Tyre	
Tyres	Option I - 215/60 R17 96H (Radial /Tubeless /Normal) Option II - 215/55 R18 95H (Radial /Tubeless /Normal) Option III -215/65 R16 98V (Radial /Tubeless /Normal) for spare only
Wheel rims	Option I : 6.5 x 17" Hyper style steel wheel Option II : 6.5 x 17" Alloy wheel Option III : 6.5 x 18" Alloy wheel Option IV : 6J x 16" steel wheel (for spare only)
Cab / Body	
Type	Steel Monocoque Body
Electrical System	
System voltage	12 Volts
Auxiliary battery	12V DIN 40 Ah
Main Chassis Dimension (in mm)	
Wheel base, mm	2560
Track front, mm	1550

TECHNICAL SPECIFICATION

Parameter	Curvv EV
Overall height, mm	Unladen - 1637
Track rear, mm	1540
Overall length, mm	4310
Max. Width, mm	1810
Ground clearance, (Laden) mm	Option I - 169 mm , Option II - 162 mm
Performance	
Max. Speed	Option I - 150 Kmph , Option II - 160 Kmph
Max. Recommended grad ability	16.8 Degrees
Minimum Turning Circle Dia. in meter as per IS:12222	10.7 m
Minimum Turning Clearance circle dia. in meters as per IS:12222	11.4 m
Weight	
Gross vehicle weight (Laden), kg	2010 - 2100
Kerb weight (unladen), kg	1600-1690

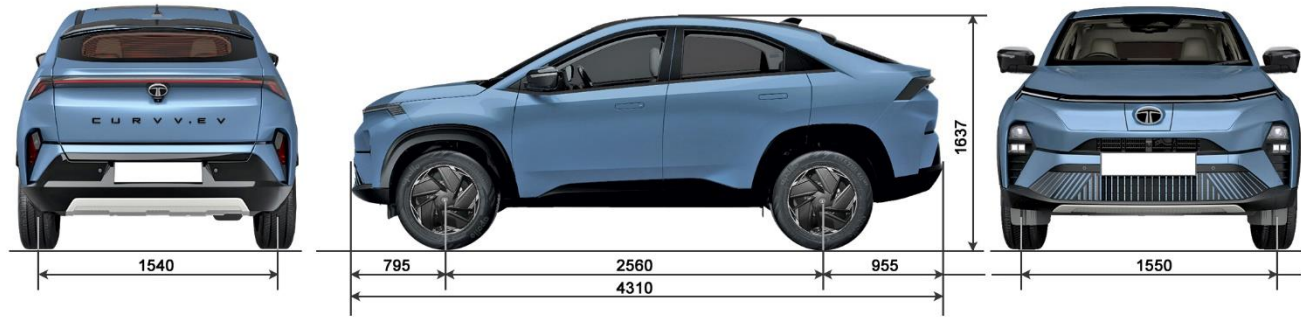
VEHICLE DIMENSIONS

NOTE: Dimensions are in mm unladen condition

TECHNICAL SPECIFICATION

AGGREGATE IDENTIFICATION



VIN plate near co-driver seat



Chassis No. punching near driver seat

SERVICE INSTRUCTIONS

The TATA **CURVV.EV** has been manufactured to give you economical and trouble free performance. To achieve this, please follow the instructions as stated.

Your vehicle is entitled to three free services (labour only). The free service coupons are attached to the sales invoice. Please present these coupons to the servicing dealer while availing free services.

1st free service - At 1000-2000 kms. OR 2 months, whichever is earlier.

2nd free service - At 7000-8000 kms. OR 6 months, whichever is earlier.

3rd free service - At 14500-15500 kms. OR 12 months, whichever is earlier.

All services other than free services are chargeable.

Servicing of the vehicle can be done at any TATA MOTORS EV Authorised Dealer Workshop or TATA MOTORS EV Authorised Service Centre (TASC).

Warranty claims can be settled by any TATA MOTORS EV Authorised Dealer Workshop or TATA MOTORS EV Authorised Service Centre (TASC).

MAINTENANCE AND CARE

SERVICE SCHEDULE

Periodic Maintenance Schedule		Free Service			Paid Service																	
Service Intervals In Km (kilometer) or Months Whichever Comes Earlier	Kms	1500	7500	15000	22500	30000	37500	45000	52500	60000	67500	75000	82500	90000	97500	105000	112500	120000	127500	135000	142500	150000
	Months	2	6	12	18	24	30	36	42	48	54	60	66	72	78	84	90	96	102	108	114	120
I: Inspect (Check, Clean, Correct, Top Up, Adjust, Repair, Replace As Necessary) T: Tightening Torque R: Replace																						
S N	GENERAL																					
1	Wash the vehicle & Clean Condenser Fins	To be done at every service																				
2	Check & Top up Fluids (If required): Transaxle Oil, Coolant, Brake Fluid, Battery Electrolyte, Wind Screen washer fluid	To be done at every service																				
3	Check HV Battery box under the vehicle for cracks/leakages	To be done at every service																				
4	Inspect and clean (if required) HV Battery breather plug	To be done at every service																				
5	Check all the HV cables for looseness, cuts, wear & tear	To be done at every service																				
6	Clean Charging socket area. Also clean dust around hinge area of Charging Port Housing lid.	To be done at every service																				

MAINTENANCE AND CARE

Periodic Maintenance Schedule		Free Service			Paid Service																	
Service Intervals In Km (kilometer) or Months Whichever Comes Earlier	Kms	1500	7500	15000	22500	30000	37500	45000	52500	60000	67500	75000	82500	90000	97500	105000	112500	120000	127500	135000	142500	150000
	Months	2	6	12	18	24	30	36	42	48	54	60	66	72	78	84	90	96	102	108	114	120
I: Inspect (Check, Clean, Correct, Top Up, Adjust, Repair, Replace As Necessary) T: Tightening Torque R: Replace																						
7	Inspect Battery cooling system (BCS) and Traction cooling system (TCS)	To be done at every service																				
8	Coolant - Battery cooling system (BCS) and Traction cooling system (TCS)	Replace Every 60,000 km/ 36 Months whichever comes earlier																				
9	Using TDS diagnostic tool check and capture all DTC's. Clear all DTCs.	To be done at every service																				
10	Check all door latches & striker operations, apply grease if required.			I		I		I		I		I		I		I		I		I		I
11	Check for tightening torque of bolt, nuts, stud and fasteners of cradle FEM frame & A, B C mounts.	T	T	T	T	T	T	T	T	T	T	T	T	T	T	T	T	T	T	T	T	T

MAINTENANCE AND CARE

Periodic Maintenance Schedule		Free Service			Paid Service																	
Service Intervals In Km (kilometer) or Months Whichever Comes Earlier	Kms	1500	7500	15000	22500	30000	37500	45000	52500	60000	67500	75000	82500	90000	97500	105000	112500	120000	127500	135000	142500	150000
	Months	2	6	12	18	24	30	36	42	48	54	60	66	72	78	84	90	96	102	108	114	120
I: Inspect (Check, Clean, Correct, Top Up, Adjust, Repair, Replace As Necessary) T: Tightening Torque R: Replace																						
12	Check condition of rubber bushes/parts in lower control arms, front and rear coil spring seats, front & rear bump stoppers, anti-roll bar links, rear twist beam, rubber boots/dust cover/bellow in rack & pinion, steering and suspension ball joints, steering column. Replace if necessary.																					
BRAKES																						
13	Check front & rear brake pads. Replace if necessary.																					

MAINTENANCE AND CARE

Periodic Maintenance Schedule		Free Service			Paid Service																	
Service Intervals In Km (kilometer) or Months Whichever Comes Earlier	Kms	1500	7500	15000	22500	30000	37500	45000	52500	60000	67500	75000	82500	90000	97500	105000	112500	120000	127500	135000	142500	150000
	Months	2	6	12	18	24	30	36	42	48	54	60	66	72	78	84	90	96	102	108	114	120
I: Inspect (Check, Clean, Correct, Top Up, Adjust, Repair, Replace As Necessary) T: Tightening Torque R: Replace																						
14	Replace brake fluid and check brake system components for leakages	Replace Every 45,000 km/ 24 Months whichever comes earlier																				
15	EPB operation		I	I		I		I		I		I		I		I		I		I		I
WHEELS & TYRES																						
16	Wheel alignment & balancing			I		I		I		I		I		I		I		I		I		I
17	Check Tyre pressure, condition & rotate.		I	I	I	I	I	I	I	I	I	I	I	I	I	I	I	I	I	I	I	I
TRANSAXLE																						
18	Oil change interval (First at 7.5K / 6M)		R			R				R				R				R				R

MAINTENANCE AND CARE

Periodic Maintenance Schedule		Free Service			Paid Service																	
Service Intervals In Km (kilometer) or Months Whichever Comes Earlier	Kms	1500	7500	15000	22500	30000	37500	45000	52500	60000	67500	75000	82500	90000	97500	105000	112500	120000	127500	135000	142500	150000
	Months	2	6	12	18	24	30	36	42	48	54	60	66	72	78	84	90	96	102	108	114	120
I: Inspect (Check, Clean, Correct, Top Up, Adjust, Repair, Replace As Necessary) T: Tightening Torque R: Replace																						
ELECTRICAL																						
19	Check specific gravity of battery electrolyte for 12V Aux. battery		I	I	I	I	I	I	I	I	I	I	I	I	I	I	I	I	I	I	I	I
20	Headlamp focusing			I		I		I		I		I		I		I		I		I		I
A.C. SYSTEM																						
21	Inspect Air-conditioning / HVAC System for satisfactory performance	To be done at every service																				
22	Replace Pollen filter (if applicable)			R		R		R		R		R		R		R		R		R		R
23	Replace Combi PM2.5 filter (if applicable)			R		R		R		R		R		R		R		R		R		R

MAINTENANCE AND CARE

Periodic Maintenance Schedule		Free Service			Paid Service																	
Service Intervals In Km (kilometer) or Months Whichever Comes Earlier	Kms	1500	7500	15000	22500	30000	37500	45000	52500	60000	67500	75000	82500	90000	97500	105000	112500	120000	127500	135000	142500	150000
	Months	2	6	12	18	24	30	36	42	48	54	60	66	72	78	84	90	96	102	108	114	120
I: Inspect (Check, Clean, Correct, Top Up, Adjust, Repair, Replace As Necessary) T: Tightening Torque R: Replace																						
SUNROOF																						
24	Clean guide rails and drain holes			I		I		I		I		I		I		I		I		I		I
EXTERIOR TRIM																						
25	Greasing of the Charging Port Housing lid mechanism			I		I		I		I		I		I		I		I		I		I

Kms or months whichever occurs earlier, Note - Additionally, Tyre pressure to be checked every 15 days

MAINTENANCE AND CARE

* More frequently for vehicle, operating in severe condition

Severe conditions as below-

A: Repeatedly driving short distance of less than 7 km.

B: Extensive low speed driving for long distances.

C: Driving on rough, dusty, muddy, unpaved, graveled or salt-spread roads.

D: Frequently driving in heavy traffic area & in stop & go condition

E: Driving only on uphill, downhill, or mountain roads.

F: Vehicle towing, driving for petrol car, taxi, or other commercial use

G: Frequently driving under high speed & acceleration.

NOTE

- *In Free service, labor charges are free, any parts and consumables will be chargeable.*
- *Filters, Fluid, Consumables, Grease, Components, wheel alignment Wheel Balancing and weights etc will be replaced on chargeable basis.*
- *Check the coolant level and top up as required, replace if it is contaminated /discolored or there is sludge formation.*
- *Periodic maintenance Schedule is for reference. TMPV reserves the rights to change the Periodic Maintenance Schedule*

MOTOR COMPARTMENT



1. Frunk
2. Brake Fluid Reservoir
3. Coolant Tank
4. Low Voltage Battery
5. Windshield Washer Container
6. Motor Compartment Fuse Box

MAINTENANCE AND CARE

BRAKE FLUID LEVEL

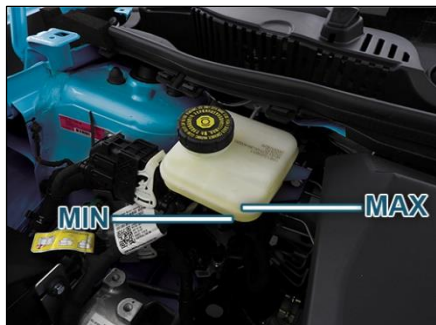

The level of the brake fluid should be between the 'MIN' and 'MAX' marks provided on the side of the brake fluid container. If the level falls below the 'MIN' mark, add recommended brake fluid.

i NOTE

- Do not allow brake fluid to make contact with the skin or eyes.
- Do not allow brake fluid to splash or spill on the paint surface as it will damage the paint. In case of spillage, wipe it off immediately.

For more clarity about location of Brake Fluid Container and filling cap, please refer respective motor Compartment.

WINDSHIELD WASHER FLUID LEVEL



Examine if there is washer fluid in the tank. Fill it if necessary. Use a good quality fluid, diluted with water as necessary.

i NOTE

- Do not use detergent or any other additive in the windshield washer reservoir. This can severely impair visibility when sprayed on the windshield, and can also damage your vehicle's paint.
- Do not operate washer motor with no fluid in washer tank, washer motor will be damaged.

For more clarity about location of Windshield Washer Container and filling cap, please refer image of the respective motor Compartment.

12V BATTERY

- Examine the battery for electrolyte level against the marking on the battery outer case.
- Use a proper spanner to loosen and remove cables from the terminals.
- Always disconnect the negative (-ve) terminal first and reconnect it last.
- If your vehicle is equipped with Battery Sensor, then disconnect only the Sensor output cable.
- Ensure battery is securely mounted.
- If you need to connect the battery to charger, remove both the terminal to prevent damage to the vehicle electrical system.
- Apply terminal coats/spray/petroleum jelly to prevent battery terminal from oxidation.
- Refer the below Battery Sensor image for do's and don'ts.

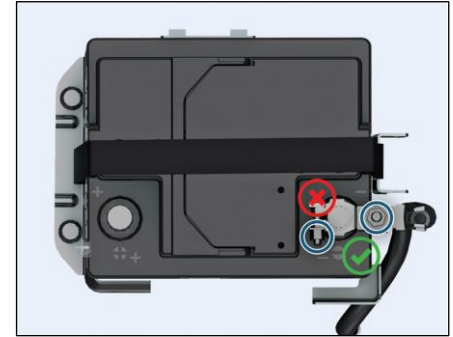

For location of battery, please refer image of the respective motor Compartment.

MAINTENANCE AND CARE

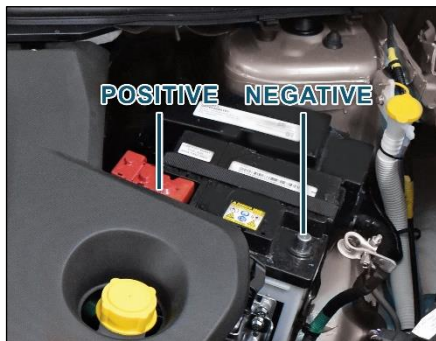

i NOTE

Use only authorized Battery recommended by TATA MOTORS. Use of any other unauthorized Battery will result into Intelligent Alternator Control (IAC) function deterioration.

i NOTE

- During normal operation, the battery generates gas which is explosive in nature. A spark or open flame can cause the battery to explode causing very serious injuries.
- Keep all sparks, open flames and smoking materials away from the battery.
- The battery contains sulphuric acid (electrolyte) which is poisonous and highly corrosive in nature. Getting electrolyte in your eyes or on the skin can cause severe burns. Wear protective clothing and a face shield or have a skilled technician to do the battery maintenance.

TYRES

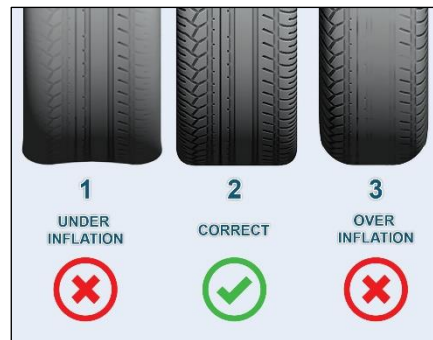

1	Under inflation	Excessive side tread wear
2	Correct tyre pressure	Uniform wear
3	Over inflation	Excessive center tread wear

Inflation

Check for inflation and condition of your vehicle tyres periodically.

Check the pressure in the tyres when they are cold.

Keeping the tyres properly inflated gives you the best combination of riding comfort, handling, tyre life and better energy efficiency.

Over inflation of tyres makes the vehicle ride bumpy and harsh. Tyres are more prone to uneven wear and damage from road hazards.

Under inflated tyres reduce your comfort in vehicle handling and are prone to failures due to high temperature. They also cause uneven wear and more energy consumption.

i NOTE

Every time you check inflation pressure, you should also examine tyres for uneven wear, damage and trapping of foreign objects in the treads and wear.

Recommended Tyre Pressures



i NOTE

Kindly refer Tyre pressure as indicated on tyre pressure sticker provided on vehicle (near driver seat).

Tyre Rotation

To help increase tyre life rotated at specified intervals or earlier depending on the operation of vehicle. The illustrations shows how to rotate tyres without spare wheel.

For 215/60 R17 & 215/55 R18 tyre with smaller size temporary tyre equipped

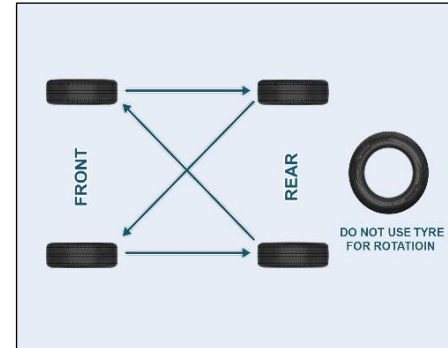

i NOTE

- Do not use spare wheel for type rotation, in case of temporary spare wheel used.

MAINTENANCE AND CARE

- Two or more temporary tyres should not be used on one vehicle.
- Tyre pressure to be checked every 15 days.
- Tyre pressure of temporary wheel is to be checked at least once in a month.

Wheel Alignment and Balancing

Alignment

Incorrect wheel alignment causes excessive and uneven tyre wear. Check wheel alignment at specified intervals.

Balancing

Wheels of your vehicle are balanced for better ride comfort and longer tyre life. Balancing needs to be done whenever tyre is removed from rim.

WARNING

If the vehicle vibrates abnormally on a smooth road, have the wheel balanced done immediately.

Special Care for Tubeless Tyres

- When you remove the tyre and install it back on the rim, take precautions not to damage tyre bead. Use tyre removal and assembly machines. Damage or cut on tyre bead may cause gradual loss of air and deflation of tyre.
- Do not scratch the inner surface of tubeless tyre with metallic or sharp object. Tubeless tyres are coated with impermeable layer of rubber from the inner surface which holds the air in the tyre. Removal of this layer due to scratching may cause gradual loss of air and deflation.
- If wheel rim gets damaged in service, get the wheel rim repaired/ replaced immediately. Running the vehicle with damaged rim may cause deflation of tyre and subsequent dislodging of tyre from rim.
- Keep the recommended inflation pressure. Over-inflation, in particular, may cause puncture or bursting of tyre.

NOTE

Life and wear pattern of tyres depends on various parameters like tyre pressure, wheel alignment, wheel balancing, tyre rotation, etc. It also largely depends on vehicle speed, load carried, usage, driving habits, road conditions, tyre quality, etc. In case fault is suspected to be due to poor quality of tyres, the same may be taken up with concerned tyre manufacturer.

Tyre Equipment

Summer tires have a tread designed to provide superior performance on dry pavement. However, the performance of these tyres will be substantially reduced in wet conditions. If you operate your vehicle on wet roads, use all season tyres for all four wheels.

Special Winter Equipment

It is recommended that the following items be carried in the vehicle during winter:

- A scraper and stiff-bristled brush to remove ice and snow from the window-sand wiper blades.
- A shovel to dig the vehicle out of snow drifts.
- Extra windshield-washer fluid to refill the reservoir tank.

VEHICLE PARKING FOR LONG DURATION

Following care is to be taken:

1. Park the vehicle in covered, dry and if possible well-ventilated premises. Ensure parking brake engaged.
2. Remove the battery terminal cables (first remove the cable from the negative terminal). Ensure that battery is fully charged.
3. Use wheel chocks to prevent movement of the car.
4. Clean and protect the painted parts using protective wax.
5. Clean and protect the shiny metal parts using commercially available special compounds.
6. Sprinkle talcum powder on the rubber windscreen wiper and lift them off the glass.
7. Slightly open the windows.
8. Cover the vehicle with a cloth or perforated plastic sheet. Do not use sheets of imperforated plastic as they

do not allow moisture on the vehicle body to evaporate.

9. Inflate the tyres to 05 bar above the normal specified pressure and check it at regular intervals.
10. Check the battery charge every six weeks.
11. Avoid parking vehicle below 20% SoC continuously for two weeks (<14 days)
12. Ideal condition to park vehicle for longer duration (> 14 days) is with 40% to 60% SoC (Disconnect the Aux battery – Ve terminal for longer duration parking)
13. After the resting period the vehicle must be charged to 100% using Slow/AC Charging before use.
14. During the resting period, the user may choose either of the following options to prevent discharge of low voltage battery.
15. Periodically (weekly once) user may switch on the remote Air conditioning for 20-30 mins. This wakes up both

MAINTENANCE AND CARE

the high voltage and low voltage systems and prevents low voltage battery from getting discharged.

16. If possible, user may choose to disconnect the negative terminal of the low voltage battery. This results in complete vehicle sleep and minimum loss of charge for both low voltage and high voltage batteries

SMART KEY BATTERY REPLACEMENT (For PEPS variant)

Procedure

1. Open rear side of key (battery cover).
2. Replace with new battery in the smart key battery slot.
3. Ensure that the “+” symbol on the battery is facing upwards. The correct polarity is shown on the battery cover.
4. Close the battery cover.
5. Make sure that the key cover is intact properly.

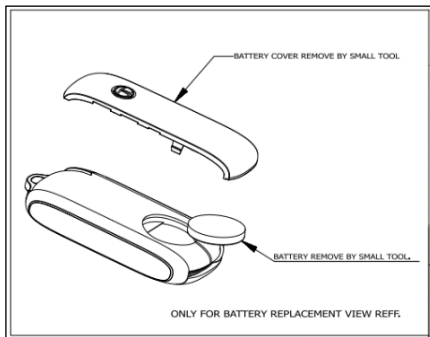

NOTE

- Use CR 2032 battery only.
- An inappropriately disposed battery can be harmful to the environment and human health. Dispose of the battery according to your local law(s) and regulation.

ON BOARD DIAGNOSTIC (OBD II) SYSTEM

The OBD system also has a diagnostic connector that can be interfaced with appropriate diagnostic tools, which makes it possible to read the fault codes stored in the Electronic Control Unit, together with a series of specific parameters for Motor operation and Diagnosis. This check can also be carried out by the traffic police. To access the diagnostic connector, open the cockpit fuse box cover, which is located on RH side below the steering wheel.

On board diagnostic located in cabin compartment fuse box.
(Refer below image)

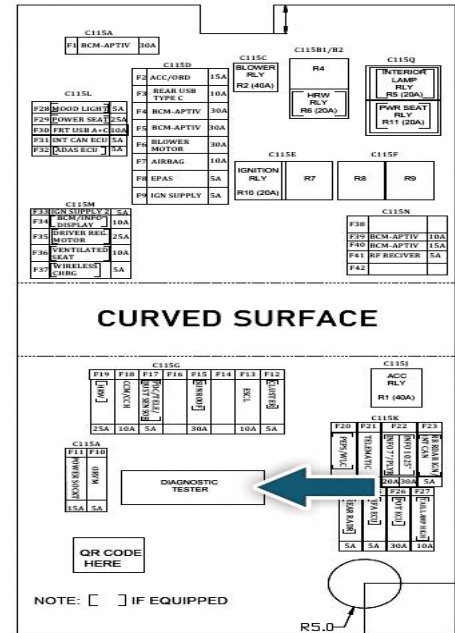

MAINTENANCE AND CARE

DO IT YOURSELF

Daily Checks

- Tyres for unusual wear, cracks or damage and embedded foreign material such as nails, stones, etc.
- Traces of fluid and oil below vehicle.
- There is sufficient charging for the trip.
- Windshield, windows, mirrors, lights, and reflectors are clean and unobstructed.
- All lamps, wipers, wiper blades and horn for proper operation.
- All switches, gauges and tell tales are working properly.
- All doors, motor compartment and tailgate are securely closed and latched.
- All doors and tail gate are securely closed and latched.
- Tool kit, jack & handle, warning triangle, owner's manual, first aid kit and vehicle documents are available and stored at their locations.

NOTE

Water dripping below the car is normal. This is due to the usage of air conditioning system.

Weekly Checks

- Coolant level
- Brake fluid level
- Windshield washer fluid level
- Battery electrolyte level

NOTE

Tyre pressure always be measured in cold conditions. Do a check of tyre pressure and condition after every 15 days, including the spare tyre.

Brake Hoses and Lines

Visually check for proper installation, chafing, cracks, deterioration and any leakage. Replace any deteriorated or damaged parts immediately.

Replacing the Components of Your EV

Since the electrical components of the vehicle are not user serviceable, it is recommended that you approach your nearest TATA MOTORS EV Authorised Service Centre to replace any electrical components of the car.

CAR CARE

Your vehicle is subjected to many external influences such as climate, road conditions, industrial pollution and proximity to the sea. These conditions demand regular care of the vehicle body. Dirt, insects, bird droppings, oil, grease and stone chip-pings should be removed as soon as possible.

Washing

Following these tips while washing your vehicle.

1. Do not wash vehicle underbody with direct jet, also don't wash the under bonnet area with water
2. Always wash your vehicle in shade and the surface is at room temperature.
3. Wash with mild vehicle wash soap like 'Car Shampoo' and use a soft bristle brush, sponge or soft cloth and rinse it frequently while washing to avoid scratches.
4. When cleaning ensure that drain holes of lower panels and rocker

panel are free from mud, slug etc to make way for entrapped water inside it to avoid corrosion.

5. To avoid scratches, please wear soft gloves. Remove finger rings, nails, wrist watch while washing.
6. To Avoid substances like petrol, diesel, kerosene, benzene, thinner, acids, acetone or other solvents that cause damage to vehicle interior, exterior and paint.
7. Avoid substances like petrol, diesel, kerosene, benzene, thinner, acids or other solvents that cause damage to paint.
8. Dry your vehicle thoroughly to prevent any damp spots.
9. Rinse all surfaces thoroughly to prevent any traces of soap and other cleaners as this may lead to the formation of stains on the painted surface later.

NOTE

- *Avoid parking the car under trees without proper cover, it will reduce*

the amount of bird droppings, tree sap and pollen contact on paint surface. Regularly remove the twigs, leaves and vegetation near the windshield areas, to avoid water stagnation.

- *Always close the sunroof while washing the vehicle.*

WARNING

Do not direct high pressure washer fluid/ water jets (Pressure above 05 bar) at electrical devices and connector during washing. This is to prevent malfunction / failure of electrical system due to water ingress.

After drying the vehicle, inspect it for chips and scratches that could allow corrosion to start. Apply touch up paint where necessary.

Cleaning of Carpets

Vacuum clean the carpet regularly to remove dirt. Dirt will make the carpet wear out faster. Periodically, shampoo the carpet to keep it looking new.

MAINTENANCE AND CARE

Use carpet cleaners (preferably foam type). Follow the instructions that come with the cleaner. Apply it with a sponge or soft brush. Keep the carpeting as dry as possible by not adding water to the foam.

NOTE

Avoid wiping of painted surface in dry condition as it may leave scratches on the painted surface.

Cleaning of Windows, Front and Rear Glasses

Clean the windows inside and outside with commercially available glass cleaners.

This will remove the haze that builds up on the inside of windows. Use a soft cloth or paper towels to clean all glass and plastic surfaces.

Waxing

Waxing and polishing is recommended to maintain the gloss and wet-look appearance of your paint finish.

1. Use good quality polish and wax for your vehicle.
2. Re-wax your vehicle when the water does not slip off the surface but collects over the surface in patches.

Polishing

Polishes and cleaners can restore shine to the painted surface that has oxidized and become dull. They normally contain mild abrasives and solvents that remove the top layer of the finish coat. Polish your vehicle, if the finish does not regain its original shine after using wax.

Interior Fabric Cleaning Tips

1. Stains should be treated immediately. If left for a long time, they can leave a permanent mark.
2. Cleaning the stains immediately is important especially for stains, which contain artificial colors in the stain creating liquid or semisolid substance. The colorant may leave a stain if kept for longer time.

3. Stain should not be removed by rubbing. As far as possible, try to blot or lift the stain with cloth or plastic spatula and then clean the remaining stain with cloth or sponge.
4. If the stain has dried, then gently brush off the material and then press with damp cloth or sponge till it disappears.
5. Do not use household detergents to clean the fabric.
6. Always use clean cotton cloth for cleaning.

Paint Care

Following guidelines will help you to protect your vehicle from corrosion effectively.

NOTE

Avoid Spillage or Direct contact of Air freshener liquid/chemicals with painted plastic parts. These chemicals may cause damage to paint like blisters, peel off, wrinkles etc.

Proper Cleaning

In order to protect your vehicle from corrosion it is recommended that you wash your vehicle thoroughly and frequently in case:

- There is a heavy accumulation of dirt and mud especially on the underbody.
- It is driven in areas having high atmospheric pollution due to smoke, soot, dust, iron dust and other chemical pollutants
- It is driven in coastal areas.
- The underbody must be thoroughly pressure washed after every three months.
- In addition to regularly washing your car, the following precautions need to be taken.

Periodic Inspection

- Regularly inspect your vehicle for any damage in the paint film such as deep scratches and immediately get them

repaired from an authorized service outlet, as these defects tend to accelerate corrosion.

- Inspect mud liners for damages.
- Keep all drain holes clear from clogging.

Proper Parking

Always park your vehicle in shade to protect it from harsh sunlight or in a well-ventilated garage so that there is no dampness on any part of the vehicle.

Wiper Care

- To prevent damage to the wipers or windshield, do not operate the wipers when the windshield is dry.
- To prevent damage to the wiper arms and other components, do not attempt to move the wipers manually.

NOTE

We strongly recommended to avoid applying any external coating solution on vehicle glazing / glasses, especially on Front & Rear Windscreen Glass. This may affect the Wiper performance & lead to poor visibility while using Wipers in wet condition/Rainy season.

MAINTENANCE AND CARE

Special Care

Illuminated Steering Wheel and Fascia
Switch Panel

- Always use dry and soft cloth for cleaning, do not use shiner, sanitizer, petrol, soap solution, detergent, foam based cleaner or any other liquid etc. as this could damage the surface.
- Do not use any sharp or other objects which can create scratch on illuminated surface.

VALUE ADDED SERVICES

Why are Corrosion Protection Waxes necessary?

Corrosion Is Caused By:

Water / salt water acid rain & atmospheric fallouts.

Critical Areas Are:

Cavities: joints, crevices, spot welds, underbody

- Corrosion is the most important factor when we talk about the vehicle life. If you treat your car you can prolong the life.
- It is very dangerous to drive around in a corroded vehicle.
- The corrosion creeps onto the vehicle from the inside and from the outside. The most dangerous kind of corrosion is often not discovered until it is too late.

Benefits of Anti - Rust Treatment:

- A professionally applied range of world class products offering real value to the new and used vehicle customer.
- The treatment has been developed to withstand the harshest environmental and climatic conditions (rust. Pollutants, stone and gravel impact, etc.).
- Insulate cabin space from external noises.
- Expensive tin work and Denting / Painting avoided.
- Higher resale value for the vehicle.
- Higher safety – uncorroded vehicle.
- 10 free checkups available.



MAINTENANCE AND CARE

TATA MOTORS has tied up with **M/s Wurth, M/s Autokrom, M/s 3M India Lt d & M/s Bardahl** for these world class treatment at affordable prices. These treatments are available in all authorized workshops. The Dealer Service Marketing Executive will explain to you the benefits and terms and conditions of this treatment.

I / We have been explained the Benefits, Terms and conditions and the prices of these treatments by the Dealer Service Marketing Executive.

I wish to avail / Do not wish to avail extended warrant policy.

Customer's Signature

Dealer's Signature

VEHICLE EXTERIOR ENRICHMENT

Why Vehicles are Painted?

- For Corrosion protection of the metal surfaces.
- Ease of application from other corrosion protection treatments.
- Cheaper than other corrosion protection methods eg. Galvanizing, anodizing.
- For decoration and identification.

Various Environmental Hazards Affecting Paints

Environmental hazards: damage your vehicle's finish.

Even as your new vehicle rolls off the assembly line, the paint is not protected.

The Enemy

Ultraviolet Rays, Pollution, Tree Sap, Bird Droppings, Car Wash Chemicals, Road Salt, Acid Rain.

Benefits: Vehicle Exterior Enrichment

- Removal of medium scratches, orange peel, oxidation, dust nibs etc. & swirl marks from painted surface.
- Restoration of original gloss levels, UV protection after gloss is restored.
- Cleaning & dressing of tyres, Bumpers and all exterior plastic moldings/trims.

TATA MOTORS has tied up **with M/s Autokrom, M/s 3M & M/s Wurth** for this world class treatment at affordable prices.

This treatment is available in all authorized workshops. The Dealer Service Marketing Executive will explain to you the benefits and terms and conditions of this treatment.



MAINTENANCE AND CARE

VEHICLE INTERIOR ENRICHMENT

Why to Protect Your New Car's Fabric Interior?

- Someone will spoil your vehicle's fabric carpet or seats.
- A significant detractor from your vehicle's resale value.
- A permanent stain on your vehicle's interior fabric.

The Enemy:

Drink spills, Food stains, mud, Ultraviolet rays, Pets, and Traffic

Benefits: Vehicle Interior Enrichment

- Removal of medium stains and dirt from all interior parts of the car i.e., carpet, upholstery and roof lining.
- Cleaning of windshield and all windows (inside and outside).
- Dressing of all internal plastics (eg: door pad trims) and rubber parts.
- The treatment involves cleaning and dressing of all parts of the exposed interiors.
- Specialized protection for seat fabric from liquid spills.

TATA MOTORS has tied up with **M/s Wurth** and **M/s Autokrom** for this world class treatment at affordable prices. This treatment is available in all authorized workshops. The Dealer Service Marketing Executive will explain to you the benefits and terms and conditions of this treatment.

I / We have been explained the Terms and conditions, Coverage and Owner's responsibility by the Dealer Service Marketing Executive.

I wish to avail / Do not wish to avail extended warrant policy.

Customer's Signature

Dealer's Signature

VEHICLE WARRANTY - TERMS AND CONDITIONS

We WARRANT each **TATA CURVV EV** vehicle and parts thereof manufactured by us to be free from defect in material and work-man ship subject to the following terms and conditions:

1. This warranty shall be for a period of **36 months from the date of sale of the car or a mileage of 1,25,000 km whichever occurs earlier. The warranty on the battery and motor shall be for a period of 96 months from the date of sale of car or a mileage of 1,60,000 KMs which-ever occur earlier.**
2. Our obligation under this warranty shall be limited to repairing or replacing, free of charge, such parts of the car which, in our opinion, are defective, on the car being brought to us or to our dealers within the period. The parts so repaired or replaced shall also be warranted for quality and workmanship but such warranty shall be co-terminus with this original warranty.
3. Any part which is found to be defective and is replaced by us under the warranty shall be our property.
4. As for such parts as Tyres, Batteries, Audio and / or Video equipment (if any), etc. not manufactured by us but supplied by other parties, this warranty shall not apply, but buyers of the car shall be entitled to, so far as permissible by law, all such rights as we may have against such parties under their warranties in respect of such parts.
5. This warranty shall not apply if the car or any part thereof is repaired or altered otherwise than in accordance with our

standard repair procedure or by any person other than from our sales or service establishments, our authorized dealers, service centres or service points in any way so as, in our judgment which shall be final and binding, to affect its reliability, nor shall it apply if, in our opinion which shall be final and binding, the car is subjected to misuse, negligence, improper or inadequate maintenance or accident or loading in excess of such carrying capacity as certified by us, or such services as prescribed in our Owner's Manual are not carried out by the buyer through our sales or service establishments, our authorized dealers, service centres or service points.

6. **This warranty shall not apply to the replacement of normal wear parts, including without limitation, drive belts, hoses, wiper blades, fuses, clutch disc, brake shoes, brake pads, cables and all rubber parts (except oil seal and glass run).**
7. This warranty shall not cover any inherent normal deterioration of the car or any of its parts arising from the actual use of the car or any damage due to negligent or improper operation or storage of the car.
8. This warranty shall not apply to normal maintenance services like oils & fluid changes, head lamps focusing, fastener retightening, center hub cap/wheel cover. wheel balancing and alignment, tyre rotation, adjustment of valve clearance, ignition timing and consumables like bulbs, air and gas leaks in case of air conditioned cars.

WARRANTY

9. This warranty shall not apply to any damage or deterioration caused by environmental pollution or bird droppings. Slight irregularities not recognized as affecting the function or quality of the vehicle or parts, such as slight noise or vibration, defects appearing only under particular or irregular operations are items considered characteristics of the vehicle.
10. This warranty shall be null and void if the car is subjected to abnormal use such as rallying, racing or participation in any other competitive sport. This warranty shall not apply to any repair or replacements as a result of accident or collision.
11. This warranty is expressly in lieu of all warranties, whether bylaw or otherwise, expressed or implied, and all other obligations or liabilities on our part and we neither assume, nor authorize any person to assume on our behalf, any other liability arising from the sale of the car or any agreement in relation thereto.
12. The buyer shall have no other rights except those set out above and have, in particular, no right to repudiate the sale, or any agreement or to claim any reduction in the purchase price of the car, or to demand any damages or compensation for losses, incidental or indirect, or inconvenience or consequential damages, loss of car, or loss of time, or otherwise, incurred or accrued.
13. Any claim arising from this warranty shall be recognized only if it is notified in writing to us or to our authorized dealer without any delay soon after such defects as covered & ascertained under this warranty.
14. This warranty is fully transferable to subsequent vehicle owner. Only unexpired remaining period of warranty applies.
15. We reserve our rights to make any change or modification in design of the car or its parts or to introduce any improvement therein or to incorporate in the car any additional part or accessory at any time without incurring any obligation to incorporate the same in the cars previously sold.

EXTENDED WARRANTY - TERMS AND CONDITIONS

TATA MOTORS recommends the purchase of its extended warranty program.

Coverage - Mechanical + Electrical

Benefits

Insures you against unforeseen break down repair bills.

Documentation is simple and hassle free.

Near cashless & speedy claim

Term

36 + 12 months or 1,25,000 kms whichever occurs first OR

36 + 24 months or 1,25,000 kms whichever occurs first OR

36 + 36 months or 1,60,000 kms whichever occurs first

Extended Warranty is available in the dealership from where you have purchased your vehicle. We strongly recommend purchase of Extended Warranty at time of purchase of your vehicle. Extended Warranty can be availed until warranty period from date of purchase of vehicle. The Dealer Service Marketing Executive shall explain to you the Terms and conditions, Coverage and Owner's responsibility.

Note

- The extended warranty comes into force once the manufacturer's warranty expires.
- It is more restrictive as by the time it comes into force the vehicle is already 36 months old.

What is Covered?

- Mechanical / Electrical break down as defined in this warranty and confirmed by the dealer within the stipulated terms and conditions.



EXTENDED WARRANTY

- TATA MOTORS dealer shall either repair or replace any part found to be defective with a new part or an equivalent at no cost to the owner for parts or labour.
- Such defective parts which have been replaced will become property of TATA PASSENGER ELECTRIC MOBILITY LTD.

What is not covered?

Please refer the Extended Warranty Booklet for details of the exclusion list. Soft copy can be available with the dealer.

Owner's Responsibility

- Proper use, maintenance and care of the vehicle in accordance with the instructions contained in the Owner's Manual and Service Booklet. The records of the same to be ensured in Owner's Manual.
- Retention of maintenance service bills.

I / We have been explained the Terms and conditions, Coverage and Owner's responsibility by the Dealer Service Marketing Executive

I wish to avail / Do not wish to avail extended warrant policy.

Customer's Signature

Dealer's Signature